



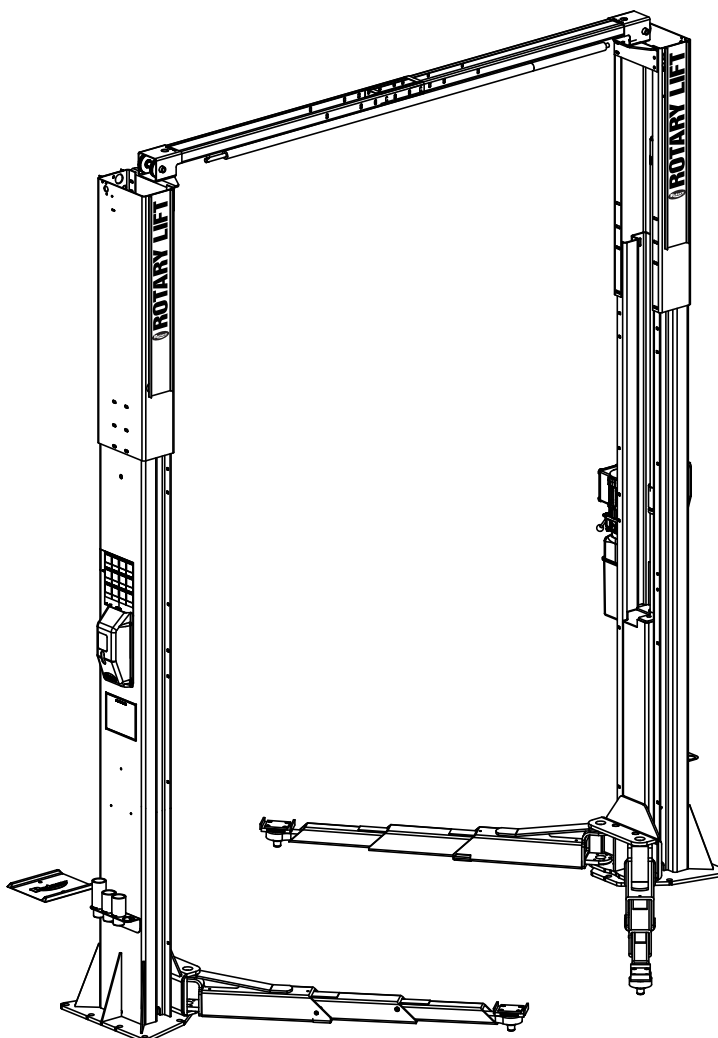
# SP012 Standard/Hummer/Sprinter

## Two Post Surface Mounted Swing Arm Frame Engaging Lift

Standard (500/700 Series) Capacity: 12,000 lbs.

Hummer (5W0/7W0 Series) Capacity: 12,000 lbs.

Sprinter (5A0/7A0 Series) Capacity: 9,000 lbs.



### OPERATING CONDITIONS

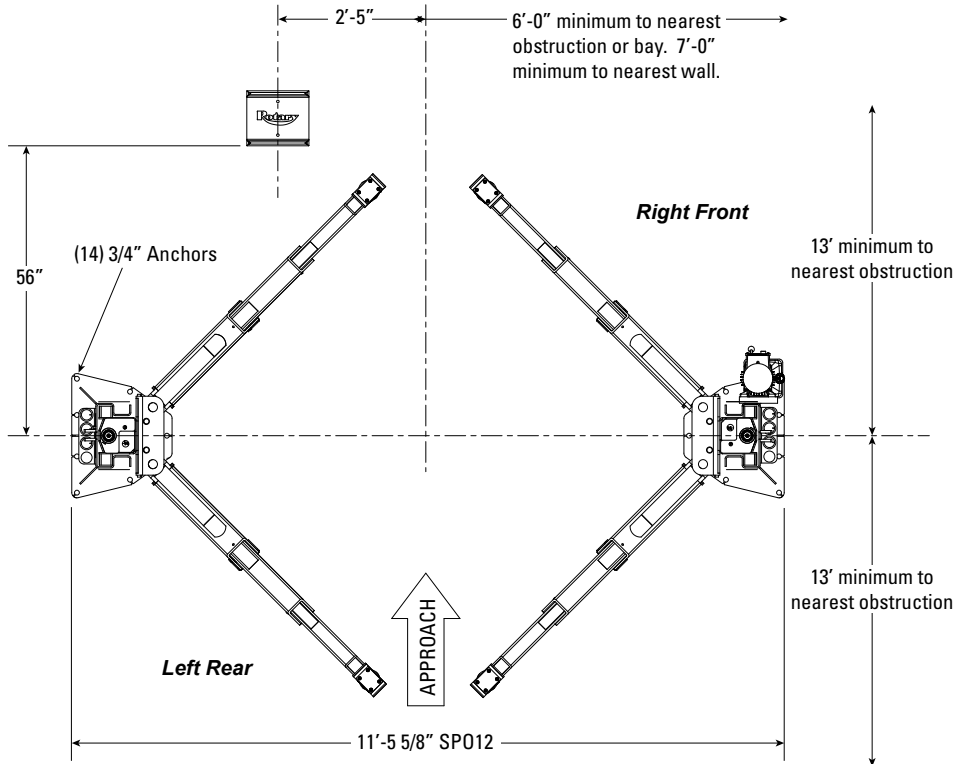
Lift is not intended for outdoor use  
and has an operating ambient temperature  
range of  
41°-104°F (5°-40°C)

### ⚠ IMPORTANT

Reference ANSI/ALI ALIS,  
Safety Requirements for  
Installation and Service of Automotive Lifts  
before installing lift.

I  
N  
S  
T  
A  
L  
L  
A  
T  
I  
O  
N  
I  
N  
S  
T  
R  
U  
C  
T  
I  
O  
N  
S

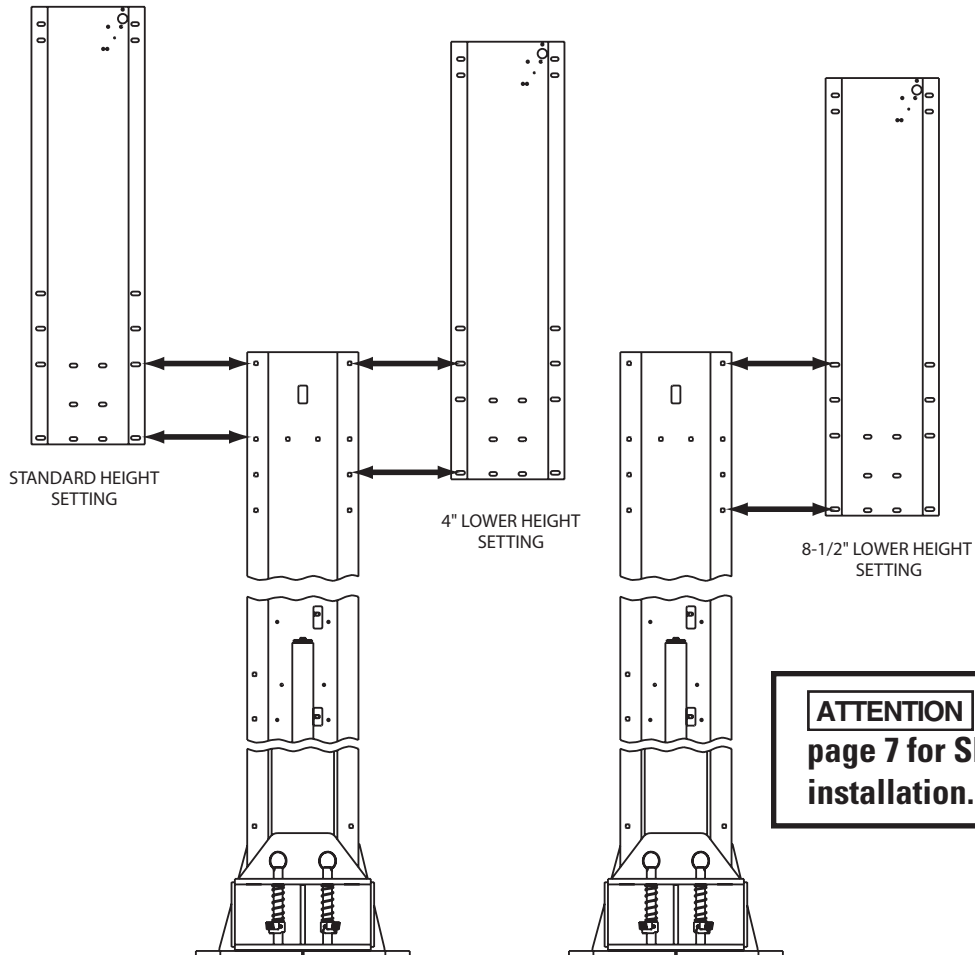
# INSTALLATION INSTRUCTIONS



**SP012 Standard (500 Series) & SP012 Sprinter (5A0 Series)  
 SP012 Standard (700 Series) & SP012 Sprinter (7A0 Series)**

**Fig. 1a**

**Note: See Pg. 3 for Hummer (5W0/7W0 Series) Lifts.**

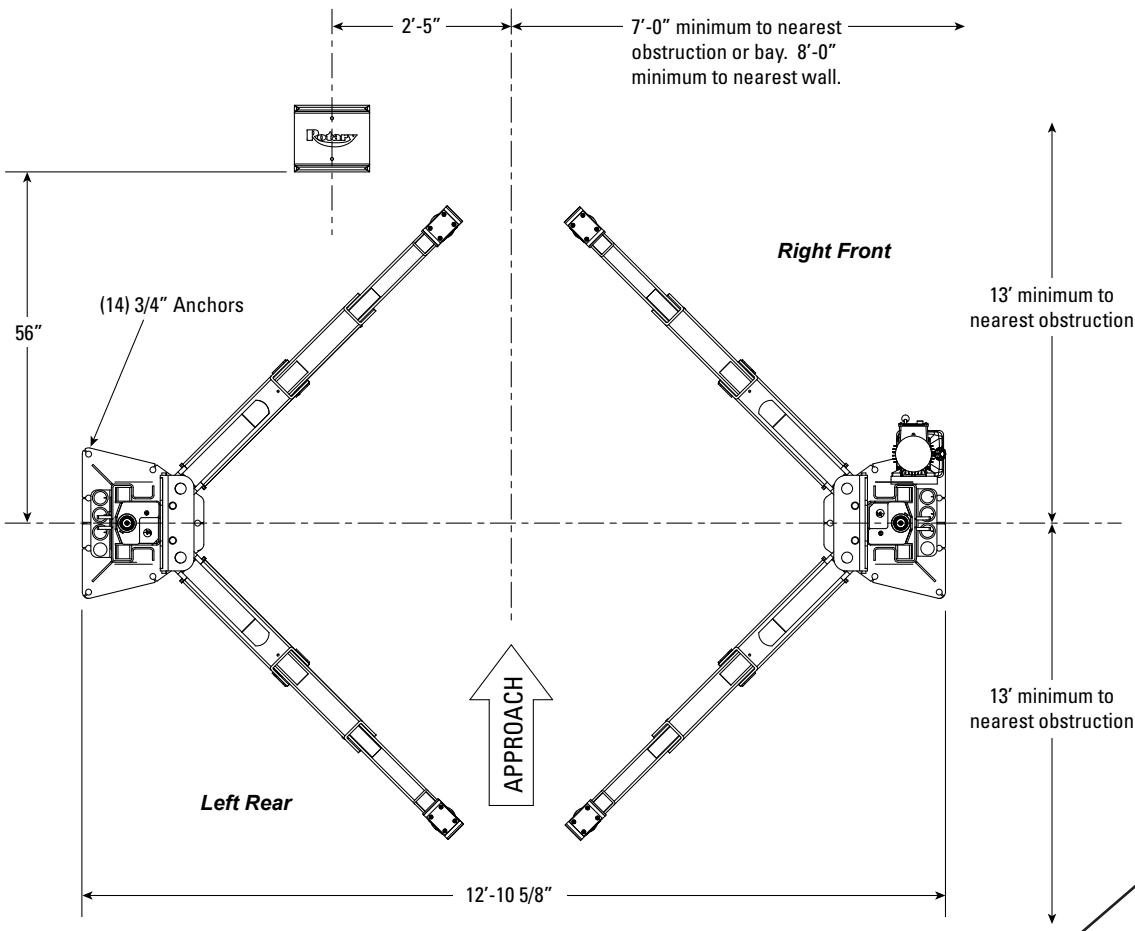


**ATTENTION:** Continue to page 7 for SP012 standard installation.

**Fig. 1b**

# SP012 Hummer Supplement Instructions

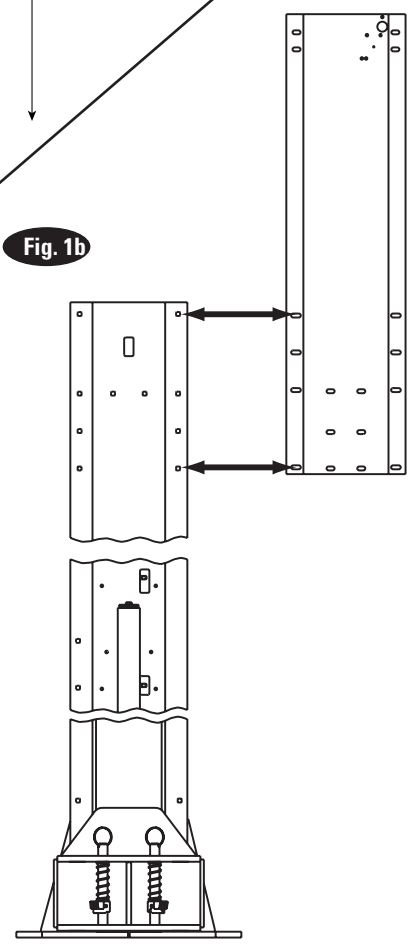
**IMPORTANT** If you have ordered a SP012 Hummer Lift (5W0/7W0 Series) these figures **MUST** be used in place of the standard instruction figures on page 2.



**Fig. 1a**

**SP012 Hummer Lift (5W0 Series)  
SP012 Hummer Lift (7W0 Series)**

**Fig. 1b**



# SP012 Hummer Supplement Instructions

## IMPORTANT

If you have ordered a SP012 Hummer Lift (5W0/7W0 Series) these figures MUST be used in place of the standard instruction figures on pages 7 & 8.

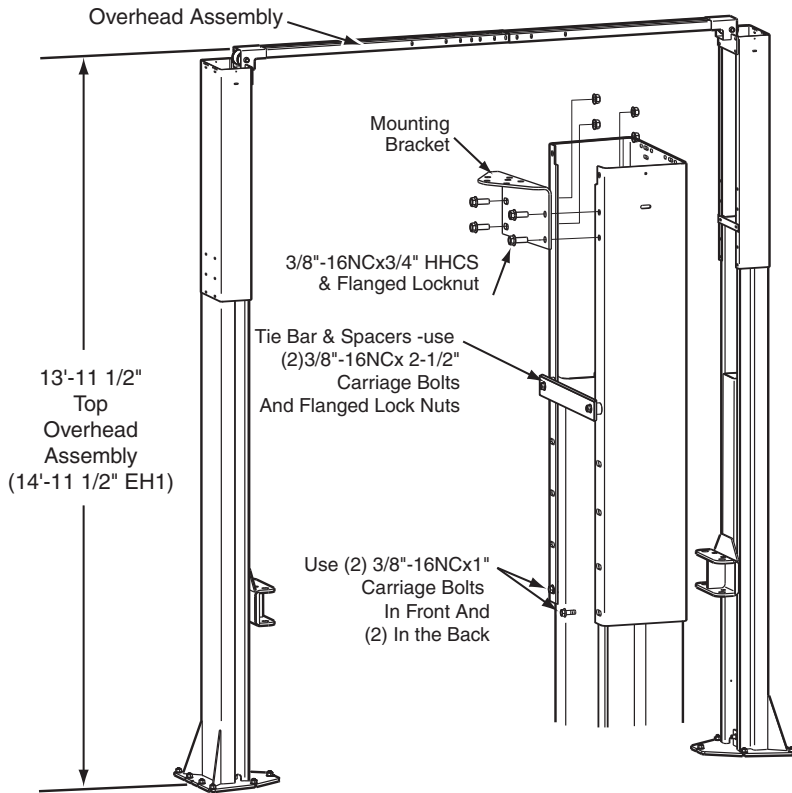


Fig. 2

**⚠ WARNING** DO NOT install this lift in a pit or depression due to fire or explosion risks.

## 1 Phase Lifts

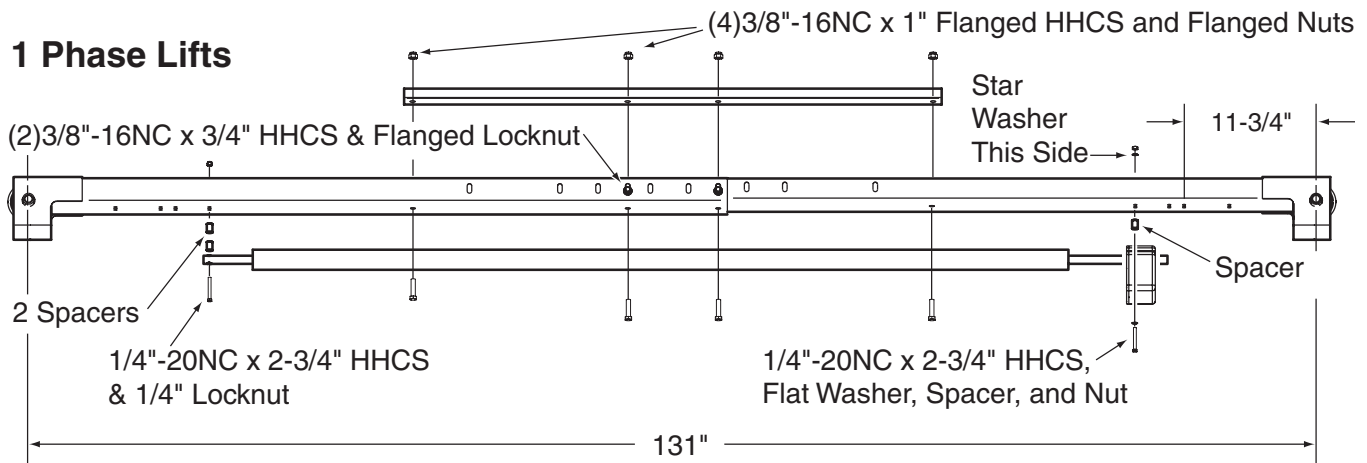
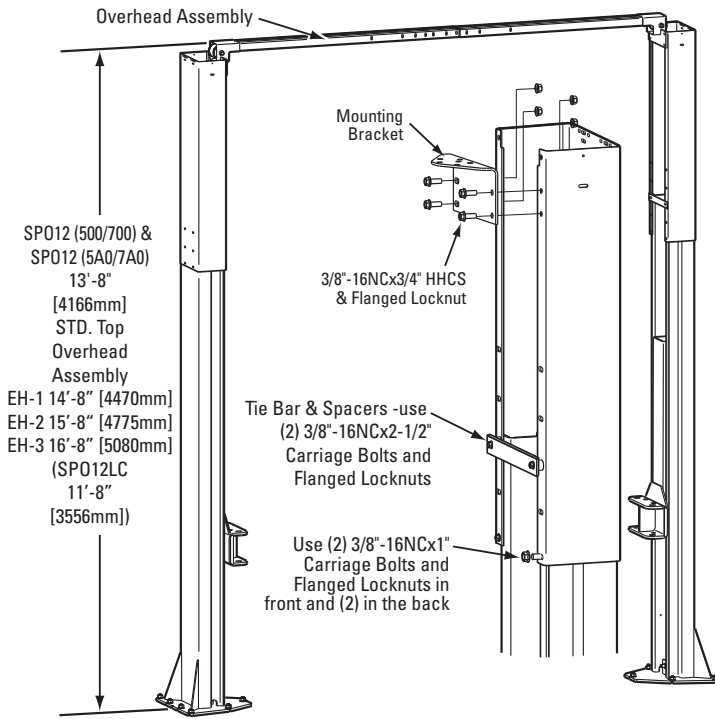


Fig. 6

**1. Lift Location:** Use architects plan when available to locate lift. Fig. 1a shows dimensions of a typical bay layout.

**Lift Height:** See Fig. 2 for overall lift height of each specific lift model. Add 1" min. to overall height to lowest obstruction.



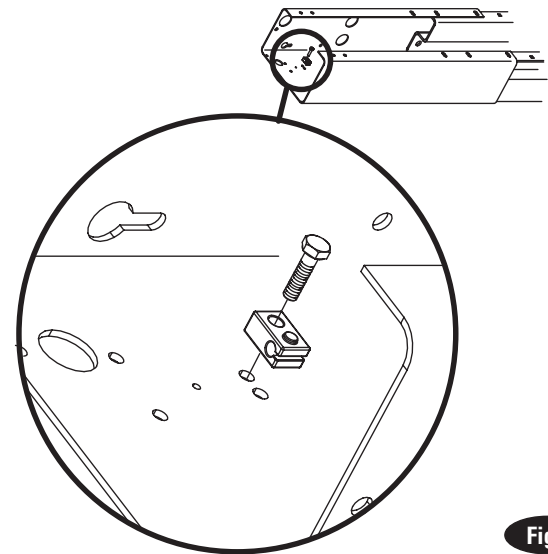
**Fig. 2**

**Note: See Pg. 3 for Hummer (5W0/7W0 Series) Lifts.**

**⚠ WARNING** DO NOT install this lift in a pit or depression due to fire or explosion risks.

**2. Latch Cable Guides:** Install the latch cable conduit guide brackets to column extensions with (1) 1/4"-20NC x 1" HHCS and 1/4"-20NC Flanged Locknuts, Fig. 3. HHCS should go through hole nearest the edge as shown, Fig. 3.

**Overhead Mounting Bracket:** Install Mounting Brackets to column extensions as shown, Fig. 2.



**Fig. 3**

**3. Column Extensions:** While column is on the ground, install column extensions using (4) 3/8"-16NC x 1" lg. Carriage Bolt and Flanged Locknut, Fig. 3 & Fig. 1b. Use (2) 3/8"-16NC x 2-1/2" lg. Carriage Bolt and Flanged Locknut to attach the tie bar and the column extension together at the column's uppermost holes, Fig. 3. The tie bar is positioned on the outside of the column extension. Adjust the column extensions plumb.

**4. Lift Setting:** Position columns in bay using dimensions shown in Fig. 1a. Place column with power unit mounting bracket on vehicle passenger side of lift. Both column base plate backs must be square on center line of lift. Notches are cut into each base plate to indicate center line of lift. Use appropriate equipment to raise carriage to first latch position. Be sure locking latch is securely engaged.

**IMPORTANT:** All star washers are to be mounted on the right side column to ensure grounding of overhead limit switch. Star washers are not needed when mounting to left side column. Notice the column extension mounting, Fig. 3 and overhead limit switch mounting as well in Fig. 3 & Fig. 6.

## 5. Concrete and Anchoring:

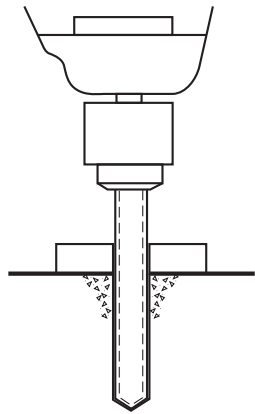
**IMPORTANT** Reference IN20294 if Sprinter long arms are going to be used for this installation or if the lift will possibly be retro-fit with them in the future. Different concrete and anchoring requirements are required.

Drill (14) 3/4" dia. holes in concrete floor using holes in column base plate as a guide. See Figs. 4 and 5 for hole requirements.

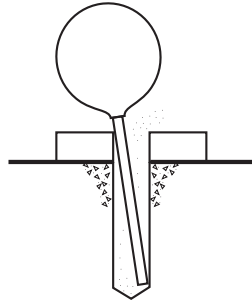
**CAUTION** DO NOT install on asphalt or other similar unstable surfaces. Columns are supported only by anchors in floor.

**IMPORTANT:** Using the horse shoe shims provided, shim each column base until each column is plumb. If one column has to be elevated to match the plane of the other column, full size base shim plates should be used (Reference Shim Kit). Recheck columns for plumb. Tighten anchor bolts to an installation torque of 110 ft-lbs. Shim thickness MUST NOT exceed 1/2" when using the 5-1/2" long anchors provided with the lift.

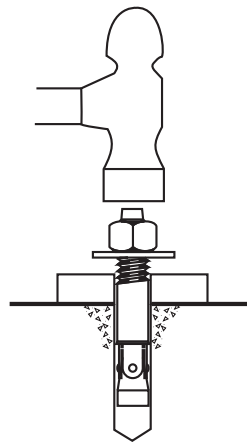
If anchors do not tighten to 110 ft-lbs. installation torque, replace concrete under each column base with a 4' x 4' x 6" thick 3000 PSI minimum concrete pad keyed under and flush with the top of existing floor. Let concrete cure before installing lifts and anchor.



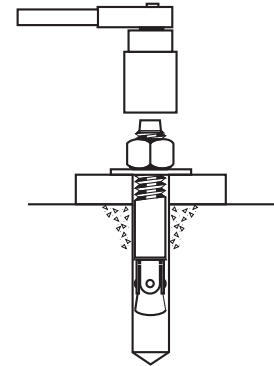
Drill holes using 3/4" carbide tipped masonry drill bit per ANSI B212.15-1994 (R2000)



Clean hole.



Run nut down just below impact section of bolt. Drive anchor into hole until nut and washer contact base.



Tighten nut with Torque wrench to 110 ft.-lbs.

Fig. 4

### 12K 2-Post Lift Anchor Installation Reference Guide

Anchor:	Min Concrete Thickness	Min Edge Distance	Min Anchor Embedment	Installation Anchor Torque Ft-lbs	Min Concrete PSI Strength - For All Standards	Concrete pad Size If Concrete Does Not Meet Requirements	Maintenance Torque Values	SEISMIC
Hilti Kwik Bolt III (3/4" x 5-1/2")	4-1/4" (108mm)	3-3/8" (86mm)	3-1/4" (83mm)	110	3000	4'x4'x6"	65	Varies by location consult with your structural engineer and manufacturer's representative.
Hilti HY200 (with HAS threaded rod)	5-1/4" (134mm)	1-3/4" (45mm)	3-1/2" (89mm)	100 / less than 3-3/4" edge distance use Torque Value of 30 FT/LBS	3000	4'x4'x6"	N/A	

**\*The supplied concrete fasteners meet the criteria of the American National Standard "Automotive Lifts - Safety Requirements for Construction, Testing, and Validation" ANSI/ALI ALCTV-2011, and the lift owner is responsible for all charges related to any additional anchoring requirements as specified by local codes. Contact customer service for further information at: 800.640.5438**

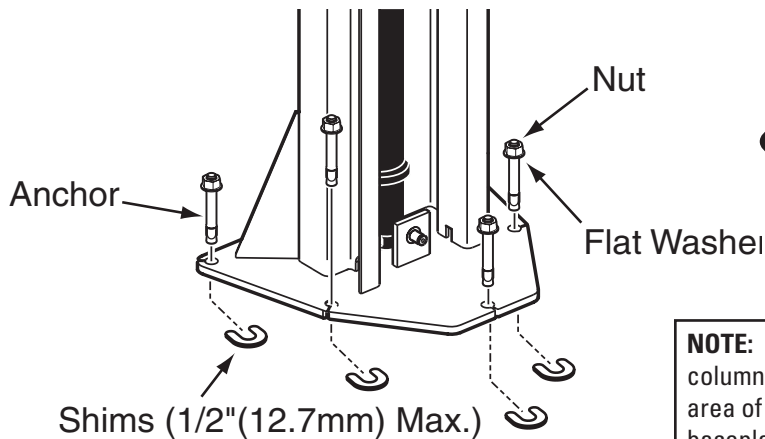


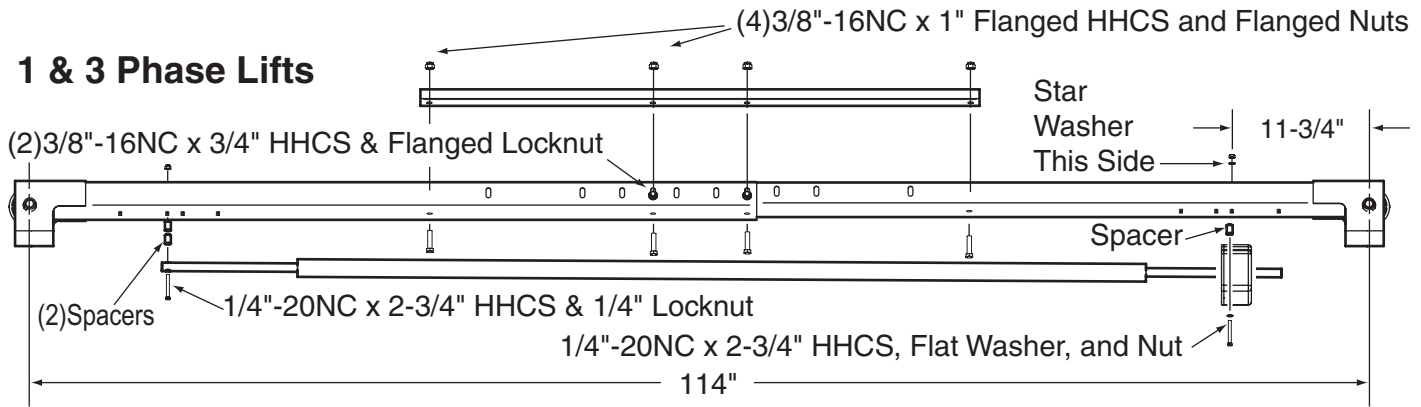
Fig. 5

**NOTE:** If more than 2 horse shoe shims are used at any of the column anchor bolts, pack non-shrink grout under the unsupported area of the column base. Insure shims are held tightly between the baseplate and floor after torquing anchors.

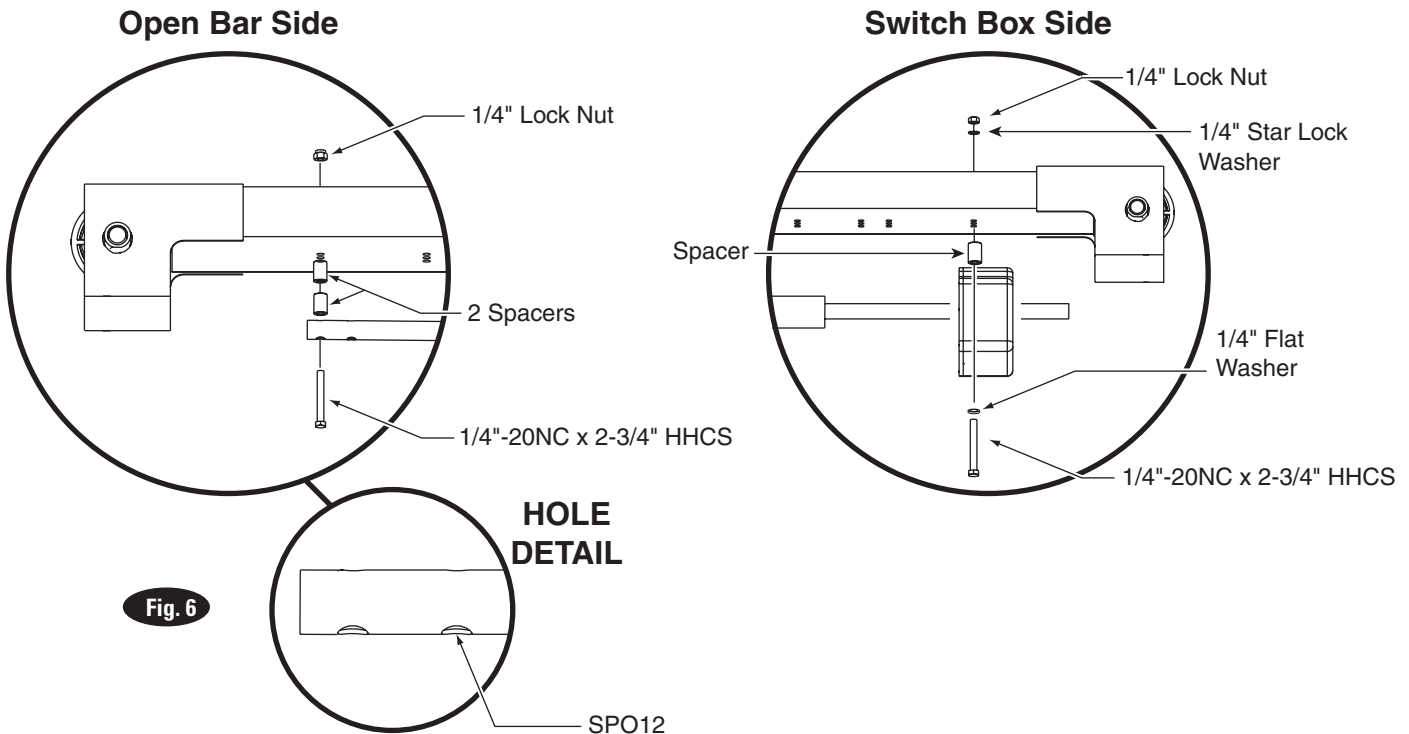
**6. Overhead Assembly:** Adjust overhead to 114" between centerline of sheave pins, Fig. 6. Install (4) 3/8"-16NC x 2-3/4" Flanged HHCS & Flanged Locknuts, do not tighten. Install overhead stiffener angle inside center of overhead using (4) 3/8"-16NC x 1" Flanged HHCS and Flanged Locknuts, see Fig. 6. Slide switch box over switch bar ensuring lockout holes face the power unit column. Use (2) 1/4"-20NC x 2-3/4" lg. HHCS, (2) flat washers, (2) 3/4" spacers, and (2) 1/4" star washers and nuts to mount switch box to overhead, Fig. 7a.

**7a. For single phase and three phase lifts with push button control box:** Insert (2) 1/4"-20NC x 2-3/4" HHCS through pivot hole in end of switch bar. Insert opposite end of bar through slot in switch mounting bracket. Then add spacers between the limit switch box and the overhead, Fig. 6, using (2) spacers and 1/4"-20NC Locknut. Tighten Hex bolt leaving 1/16" gap between the spacer and the overhead assembly.

**Note: For Fig. 6, see Pg. 4 for Hummer (5W0/7W0 Series) Lifts.**



**Hardware Detail For Overhead Assembly**





**7b. For three phase lifts with drum switch:** Remove Limit Switch cover, Fig. 7b. Insert Actuator end of Switch Bar into slot located inside Limit Switch, Fig. 7c. A small amount of silicone sealant on the lower part of the actuator will help hold it in place. Insert 1/4"-20NC x 2-3/4" HHCS through pivot hole in end of Switch Bar. **NOTE** which hole to use, Fig. 6. Then secure HHCS and Switch Bar to overhead as shown, using (2) 3/4" spacers and 1/4"-20NC Locknut. Tighten Hex bolt leaving 1/16" gap between the spacer and the overhead assembly, Fig. 6. Replace limit switch cover.

**8. Overhead:** Install overhead assembly to Mounting Bracket with (2) 3/8"-16NC x 3/4" Flanged HHCS, (2) 3/8"-16NC flanged locknut, Fig. 7d. Ensure limit switch box is mounted on power unit side. Tighten bolts at center of overhead assembly.

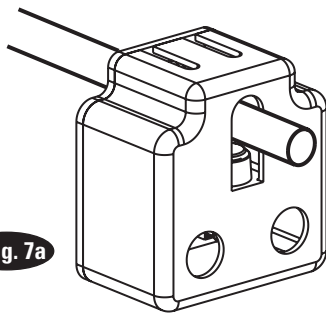


Fig. 7a

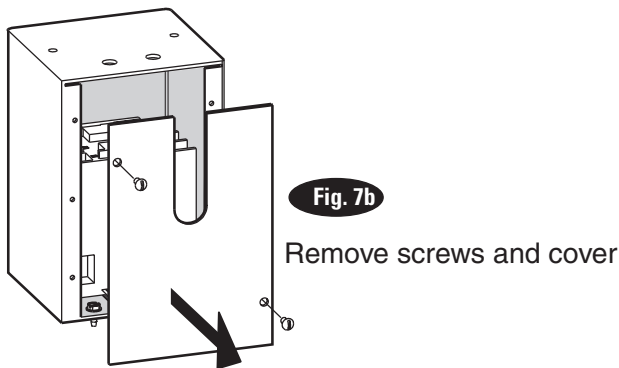


Fig. 7b

Remove screws and cover

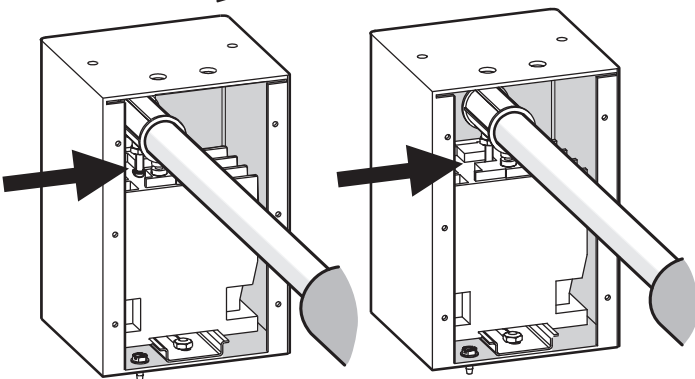


Fig. 7c

**9. Power Unit:** Put the (4) 5/16"-18NC x 1-1/2" flanged locking HHCS thru holes in power unit bracket using Push-Nuts to hold in place, Fig. 8a. Mount unit with motor up to column bracket and install (2) 5/16" Flanged locking Nuts. Install and hand tighten Branch Tee to pump until O-ring is seated. Continue to tighten the locknut to 10-15 ft-lbs., or until the nut and washer bottom out against the pump manifold. **NOTE:** You may still be able to rotate the Branch Tee. This is acceptable unless there is seepage at the O-ring. If so, slightly tighten the locknut.

**CAUTION** Over tightening locknut may tear O-ring or distort threads in pump manifold outlet.

**10. Hoses:** Clean adapters and hose. Inspect all threads for damage and hose ends to be sure they are crimped, Fig. 8b. Install hose and hose clamps, Fig. 9a & Fig. 9d.

**Flared Fittings Tightening Procedure**

1. Screw the fittings together finger tight. Then, using the proper size wrench, rotate the fitting 2-1/2 hex flats.

**IMPORTANT** Flare seat **MUST NOT** rotate when tightening. Only the nut should turn.

2. Back the fitting off one full turn.

3. Again tighten the fittings finger tight; then using a wrench, rotate the fitting 2-1/2 hex flats. This will complete the tightening procedure and develop a pressure tight seal.

**CAUTION** Overtightening will damage fitting resulting in fluid leakage.

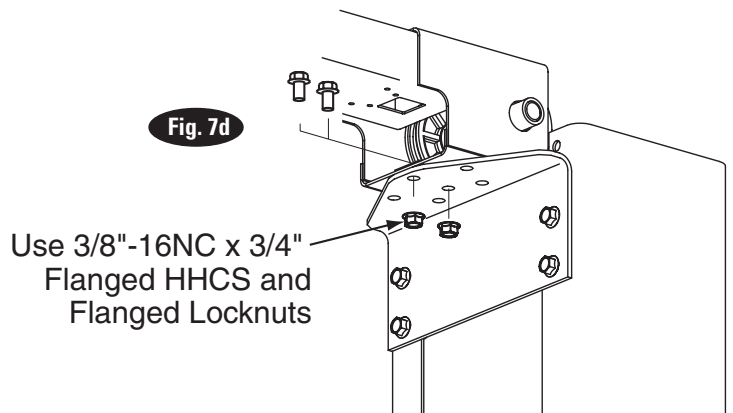
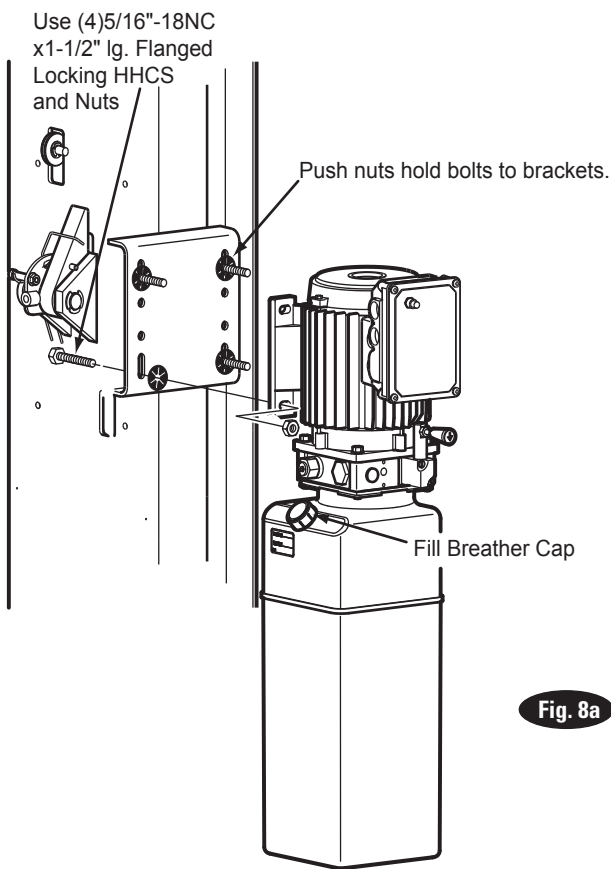


Fig. 7d

Use 3/8"-16NC x 3/4" Flanged HHCS and Flanged Locknuts



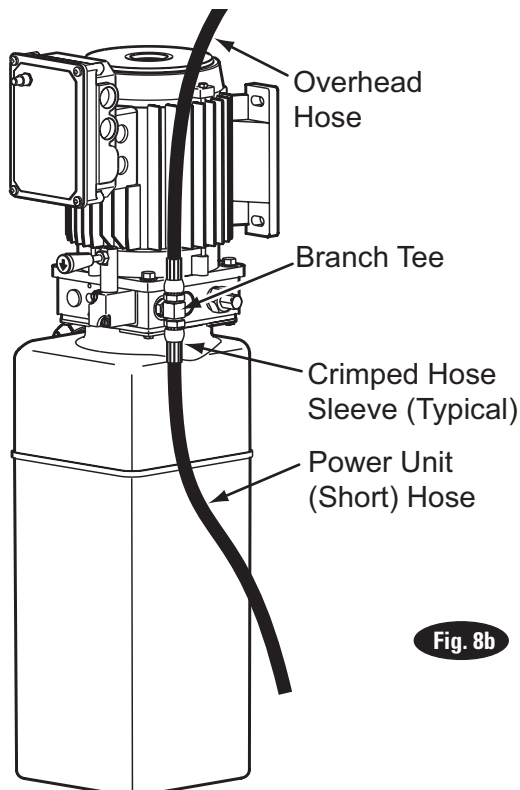
### Adapter & Hose Installation (see Fig. 9a)

1. Install Pc. (2) with metal hose clamps, on power unit column side connecting it to the cylinder (1) first.
2. Install Pc. (3) with plastic hose clamps starting at opposite column cylinder (1) and working toward the power unit column. All excess hose should be at bends & inside overhead assembly.
3. Install Pc. (4) into power unit.
4. Connect Pc. (2) & Pc. (3) to Tee (4).

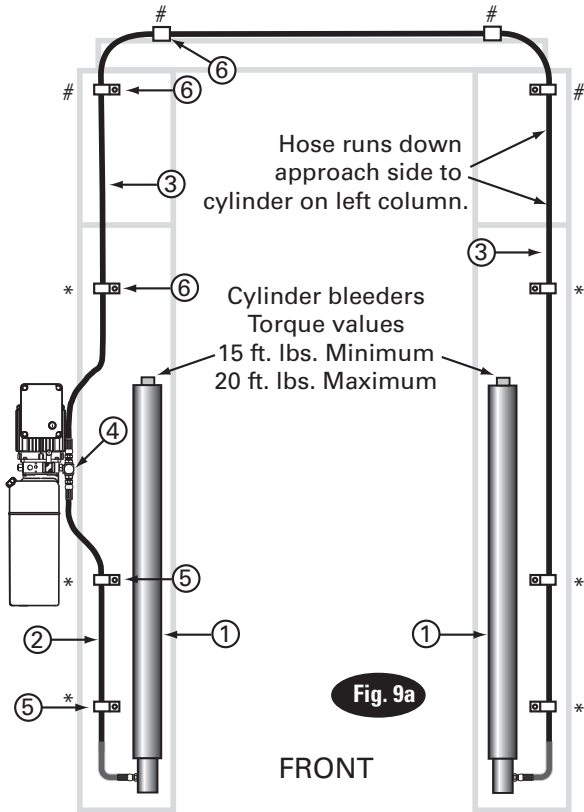
**NOTE:** Route Power Unit hose inside columns using slots provided at column base, Fig. 9b. Route Overhead Hose in column channel on outside of column, Fig. 9b. Overhead hose goes over top end of overhead assembly, Fig. 11a.

### 11. Equalizing Cables

- A) Refer to Fig. 10a for the general cable arrangement. First, run a cable end up through the small hole in the lower tie-off plate. Fig. 10b.
- B) Push the cable up until the stud is out of the carriage top opening.
- C) Run a nylon insert locknut onto the cable stud so 1/2" (13mm) of the stud extends out of the locknut.
- D) Pull the cable back down. Fig. 10b
- E) Run cable around the lower sheave, then up and around overhead sheave and across and down to the opposite carriage. Fig. 10a.
- F) Fasten the cable end to the carriage upper tie-off bracket. Tighten the locknut enough to apply light tension to the cable.
- G) Repeat procedure for the second cable. Complete lift assembly. Adjust the tension of both cables during the final adjustments.

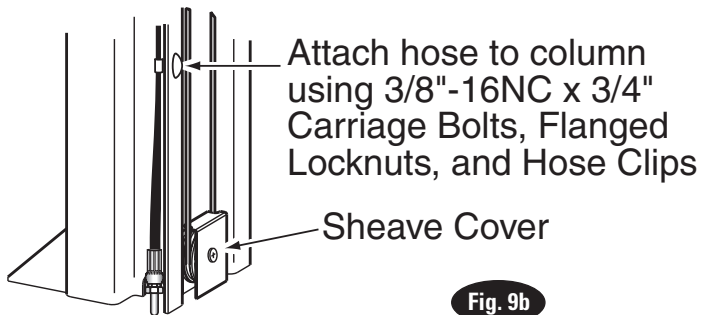


**NOTE:** Overhead hose crosses and runs down approach side of left column to cylinder.

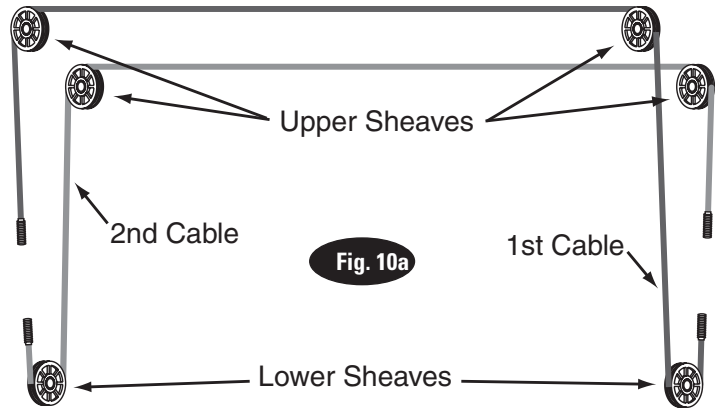


**Fig. 9a**

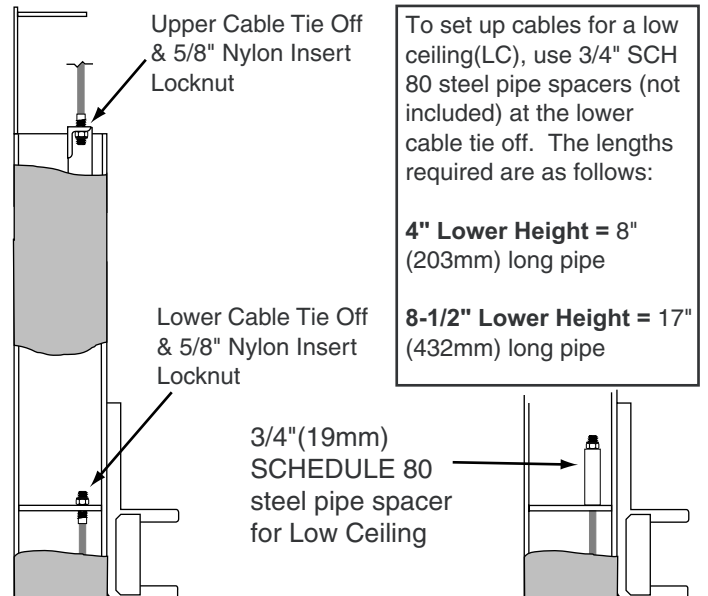
ITEM	QTY.	DESCRIPTION
1	2	Hydraulic Cylinder
2	1	Power Unit Hose
3	1	Overhead Hose
4	1	Branch Tee
5	2	Metal Hose Clips
6	8	Plastic Hose Clips
*6		3/8"-16NC x 3/4" lg. Carriage Bolts
*6		3/8"-16NC Flanged Locknuts
#4		3/8"-16NC x 3/4" lg. Flanged HHCS
#4		3/8"-16NC Flanged Locknuts



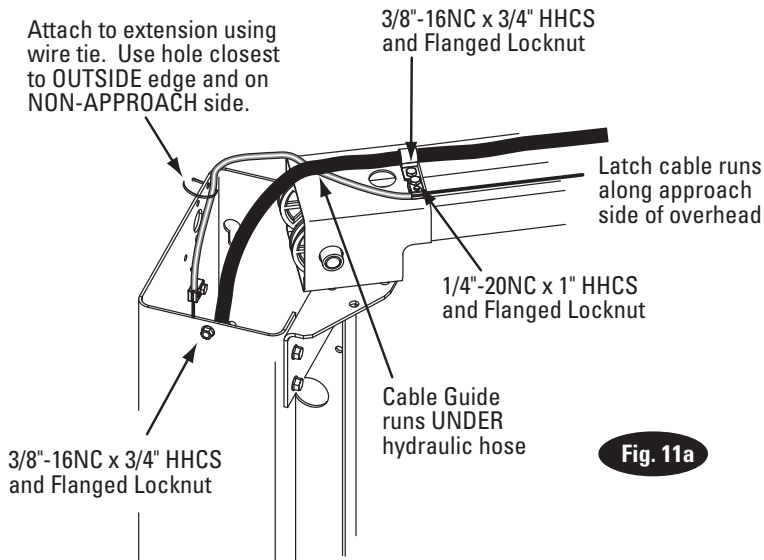
**Fig. 9b**



**Fig. 10a**



**Fig. 10b**



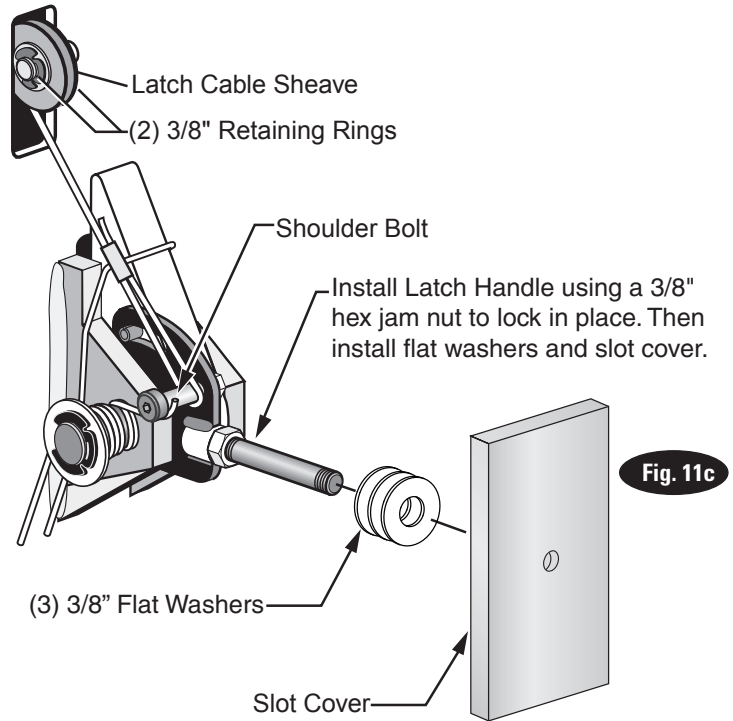
**Fig. 11a**

**IMPORTANT** Using wire ties provided, tie off cable guide to column extension as shown, Fig. 11a. Guide must be attached in hole closest to the outside edge of the column on the NON-APPROACH side.

- G) Bring the cable down inside the left column and feed the end of the cable through the lower latch cable sheave slot so that the cable is now back outside the column, Fig. 13.
- H) Install latch cable sheave and retaining rings in lower slot of non-power unit column as shown, Fig. 13.
- I) Route cable under the bottom side of the latch cable sheave, Fig. 13.
- J) At this point you **MUST** install the latch handle, jam nut, and right column latch cover Fig. 11c & Fig. 14. Install latch handle ball, Fig. 14.

**12. Locking Latch Cable**

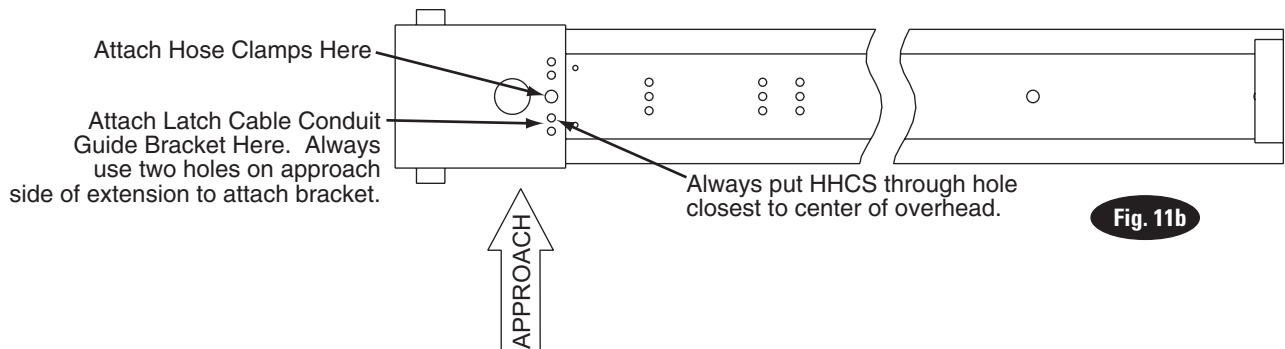
- A) Install latch cable sheave and retaining rings in upper slot of power unit column as shown, Fig. 11c.
- B) Slip loop end of cable over end of shoulder screw on right side latch control plate, Fig. 11c.
- C) Feed the other end of the cable through the latch cable sheave slot making sure that the cable is running under the bottom side of the latch cable sheave and inside the right column, Fig. 11c.
- D) Attach latch cable conduit guide brackets to overhead as shown, Fig. 11a & Fig. 11b. Always use the holes on the approach side of the lift. HHCS should be in hole nearest the center of the overhead, Fig. 11b.
- E) Route cable up inside column and through the latch cable guide, Fig. 11a & Fig. 12.



**Fig. 11c**

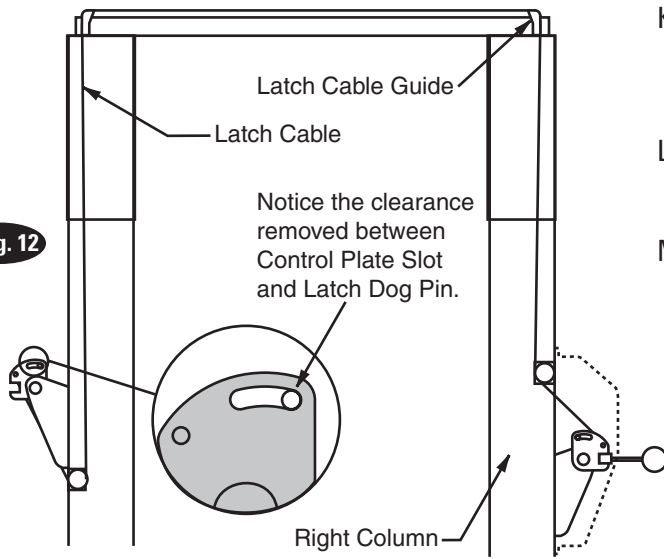
**IMPORTANT** Using wire ties provided, tie off cable guide to column extension as shown, Fig. 11a. Guide must be attached in hole closest to the outside edge of the column on the NON-APPROACH side.

- F) Continue routing cable to the left column latch cable guide, Fig. 11a & Fig. 12, routing the cable through the left column latch cable guide, Fig. 11a.



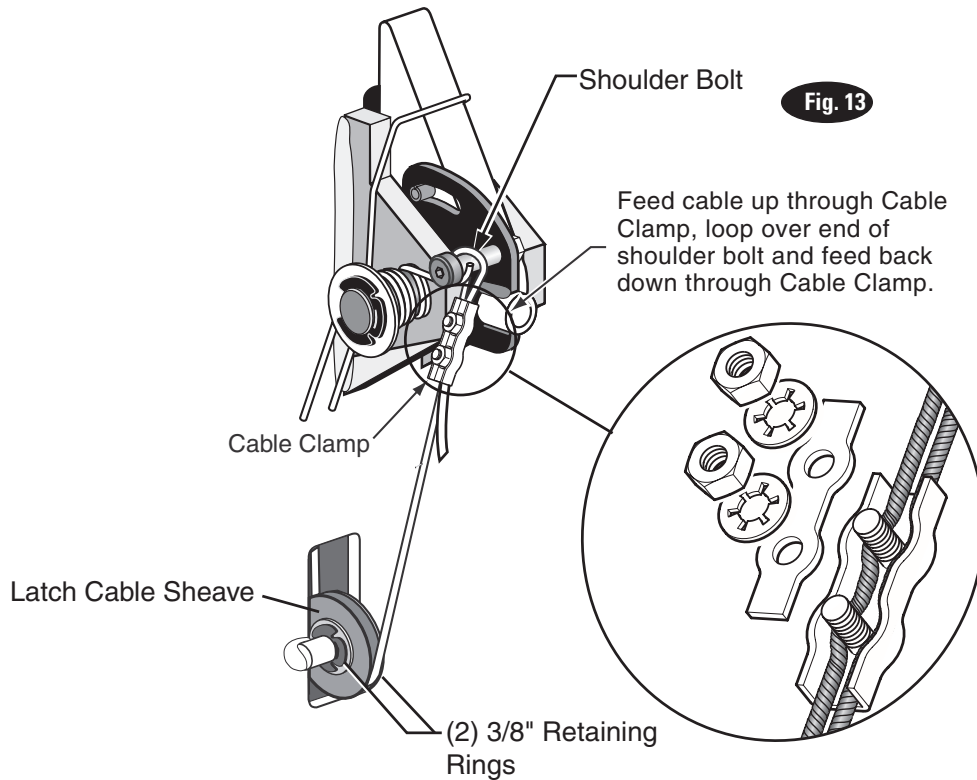
**Fig. 11b**

**Fig. 12**

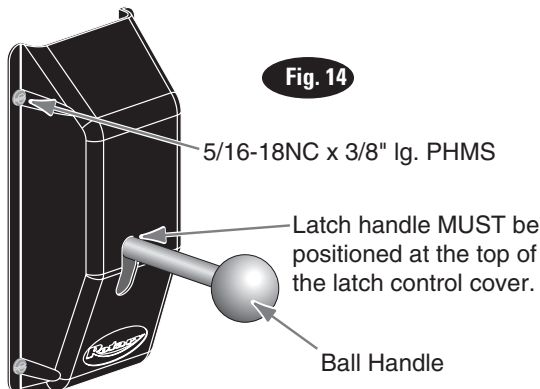


- K) Insert cable in cable clamp along one side, loop around shoulder screw and back down, inserting cable along other side of cable clamp, Fig. 13. Place top back on clamp, barely tightening.
- L) Next, pull the control plate down, Fig. 12 & Fig. 13, to eliminate any clearance between the control plate slot and the latch dog pin, Fig. 12.
- M) Using Pliers, pull cable tight and secure the clamp close to the shoulder screw. Tighten clamp.

**Fig. 13**



**Fig. 14**



**13. Electrical:** Have a certified electrician run appropriate power supply to motor, Fig. 15 & 16. Size wire for 20 amp circuit. For single phase 4HP motor wire for 30 amp circuit. See Motor Operating Data Table.

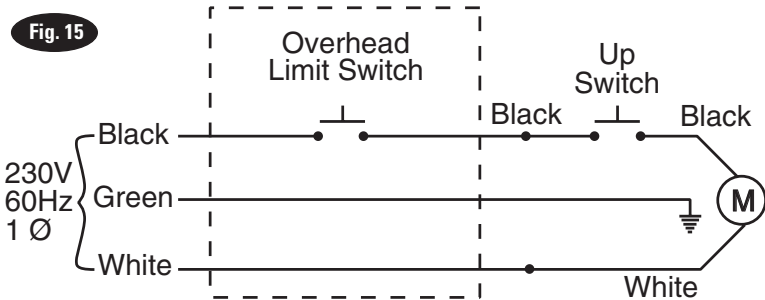
**CAUTION** Never operate the motor on line voltage less than 208V. Motor damage may occur.

**IMPORTANT:** Use separate circuit for each power unit. Protect each circuit with time delay fuse or circuit breaker. For single phase 208-230V, use 20 amp fuse. For single phase 4HP motor use 30 amp fuse. Three phase 208-240V, use 20 amp fuse. For three phase 400V and above, use 10 amp fuse. For wiring see Fig. 15, Fig. 16, and Fig.16b. All wiring must comply with NEC and all local electrical codes.

**Note:** 60Hz. single phase motor **CAN NOT** be run on 50Hz. line without a physical change in the motor.

### Single Phase Power Unit

MOTOR OPERATING DATA TABLE - SINGLE PHASE	
LINE VOLTAGE	RUNNING MOTOR VOLTAGE RANGE
208-230V 50Hz.	197-253V
208-230V 60Hz.	197-253V

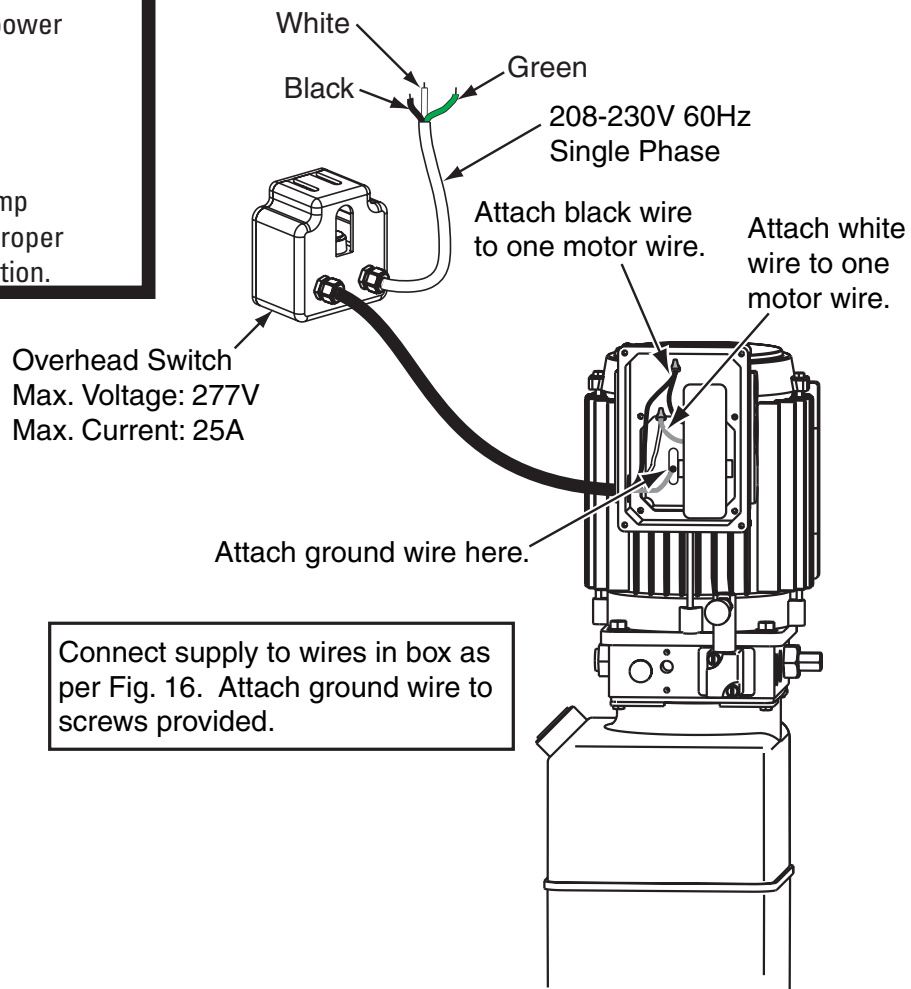


**Note:** 60Hz. Single phase motor **CAN NOT** be run on 50Hz. line without a physical change in the motor.

**NOTE:** Assure cord used for connection between the overhead switch and power unit is of the type specified in:

UL201, Sections 10.1.1.3 & 10.1.1.4

(Example: SO, G, ST0) Size for 25 amp circuit. See UL 201, Section 15 for proper wiring requirements for this connection.

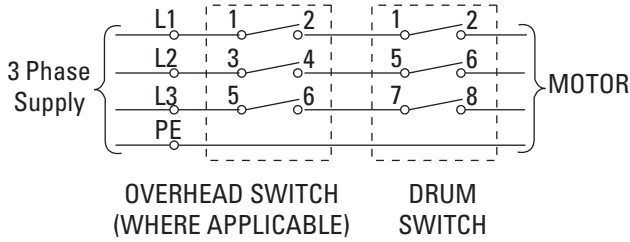


Connect supply to wires in box as per Fig. 16. Attach ground wire to screws provided.

**NOTE: Two Different Drum Switches were used please select one of the two options below. Newer model three phase lifts use the push button control box with contactor. Its instructions follow the Drum Switch instructions.**

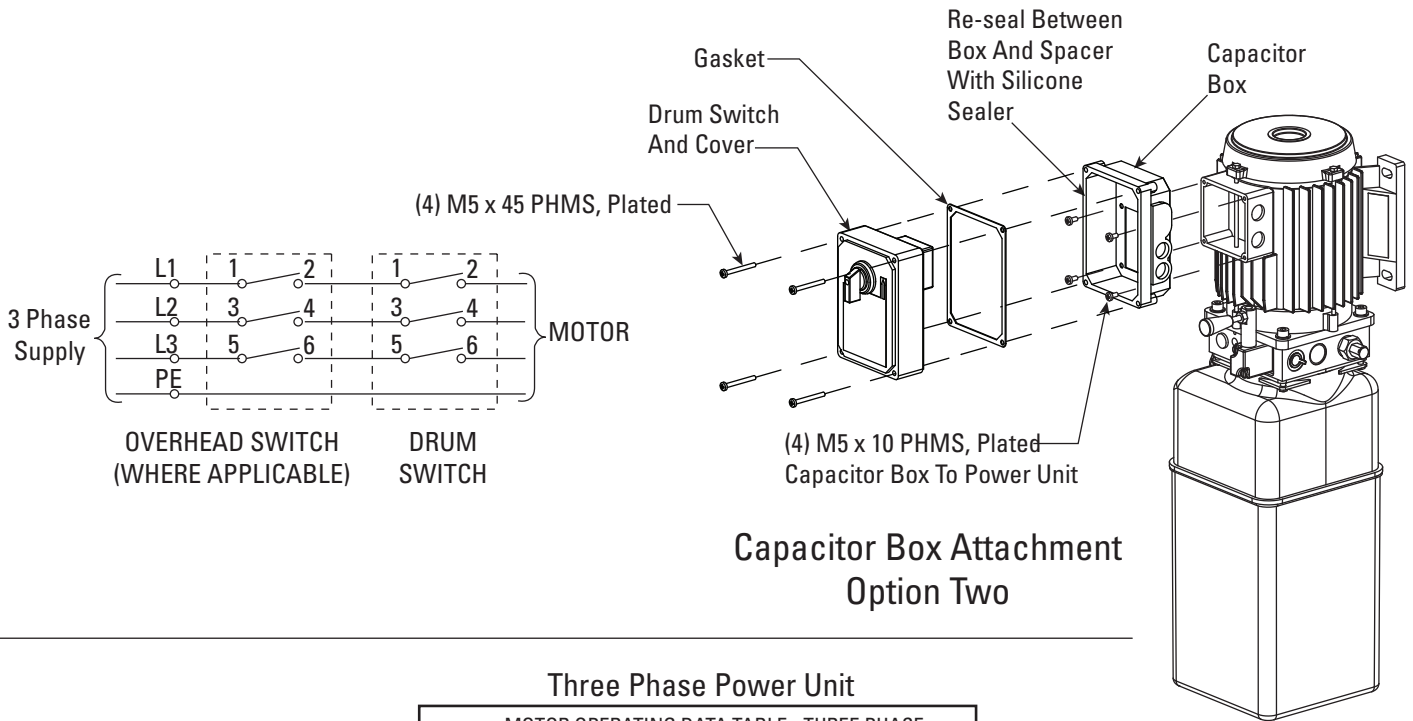
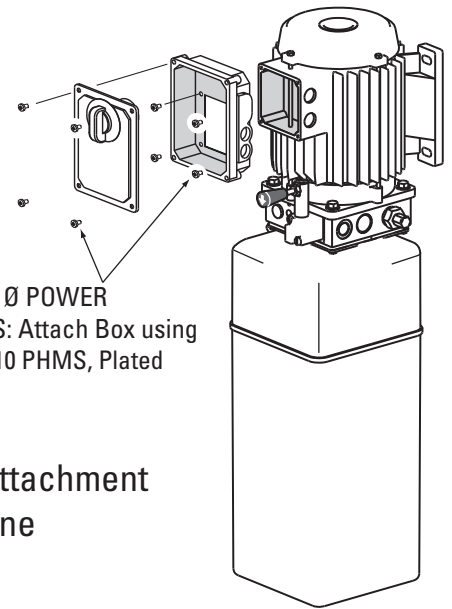
**NOTES:**

1. Unit not suitable for use in unusual conditions. Contact Rotary for moisture and dust environment duty unit.
2. Control Box must be field mounted to power unit.
3. Motor rotation is counter clockwise from top of motor.



**Capacitor Box Attachment Option One**

FOR 3 Ø POWER UNITS: Attach Box using M5 x 10 PHMS, Plated



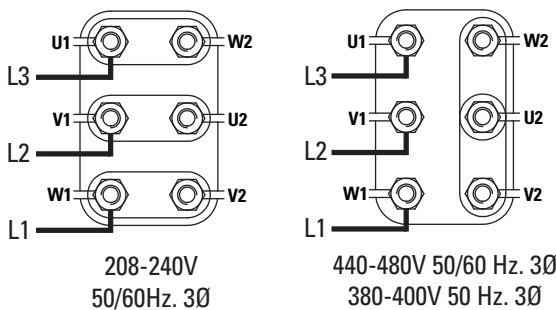
**Capacitor Box Attachment Option Two**

**Three Phase Power Unit**

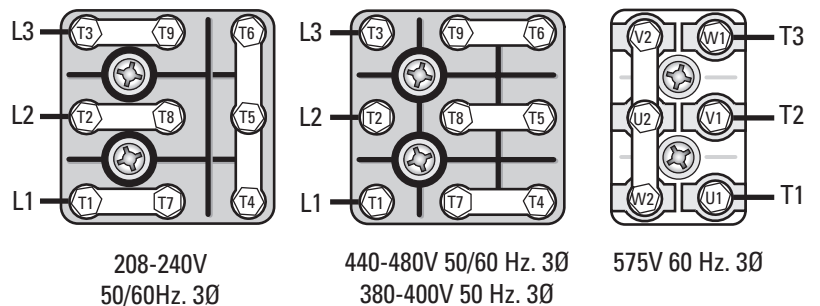
MOTOR OPERATING DATA TABLE - THREE PHASE	
LINE VOLTAGE	RUNNING MOTOR VOLTAGE RANGE
208-240V 50/60Hz.	197-253V
400V 50Hz.	360-440V
440-480V 50/60Hz.	396V-528V
575V 60Hz.	518V-632V

**Fig. 16**

**Current Pin Layouts**



**Older Pin Layouts**



14. 3Ø Control Box Installation:

- A) Attach Mounting Bracket on column, as shown in Fig. 16a, using (1) 5/16" -18NC x 1/2" Socket Head Counter Sunk Machine Screw, (2) 5/16" -18NC x 1/2" HHCS, and (2) 5/16" Flat Washers.
- B) Attach Control Box to Bracket using (4) 1/4" -20NC x 1/2" HHCS, (4) 1/4" Flat Washers, and (4) 1/4" Star Washers.
- C) Route cord through strain relief on motor and connect per table on the bottom of page 15.

Note:

The contactor in the control box has a 480V coil. For installations where the electric supply is 230V, the coil must be replaced with the extra 230V coil shipped with the control box. For 575V electric supply, the coil must be replaced with the extra 575V coil shipped with the lift.

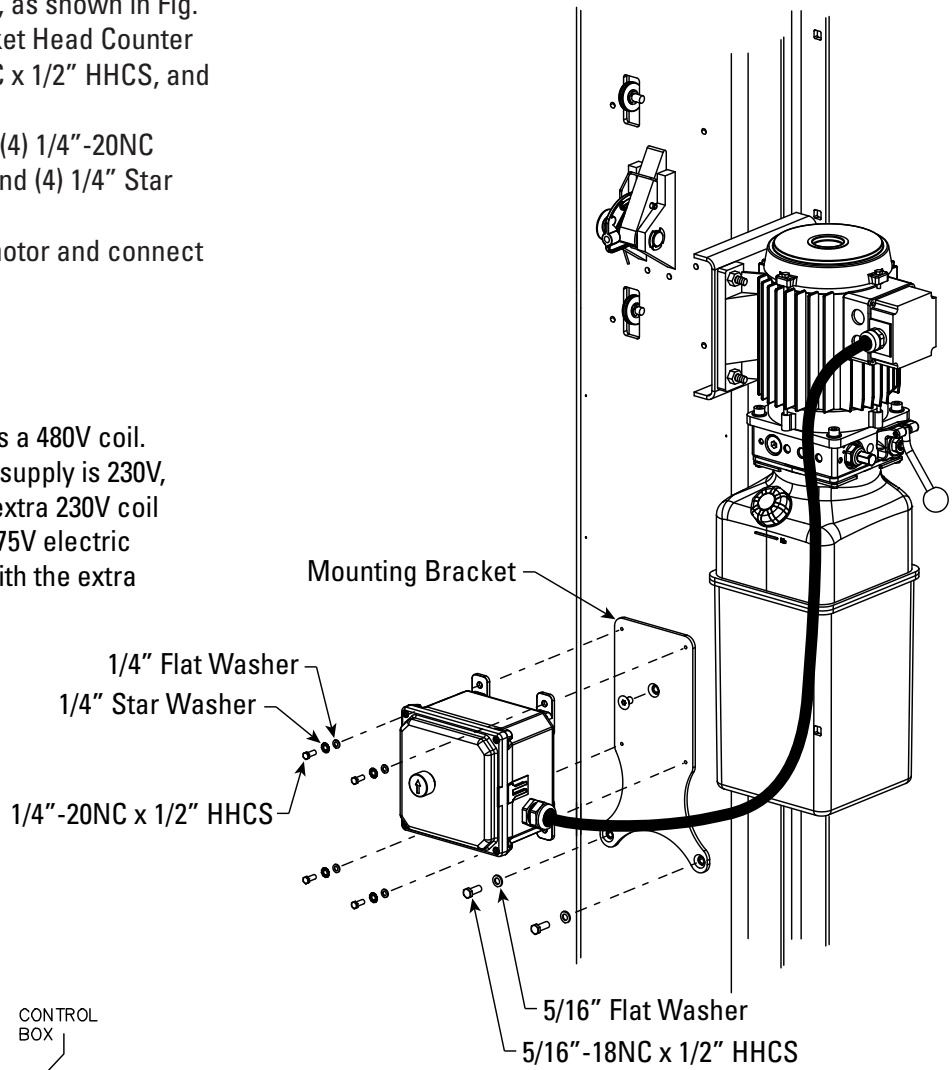


Fig. 16a

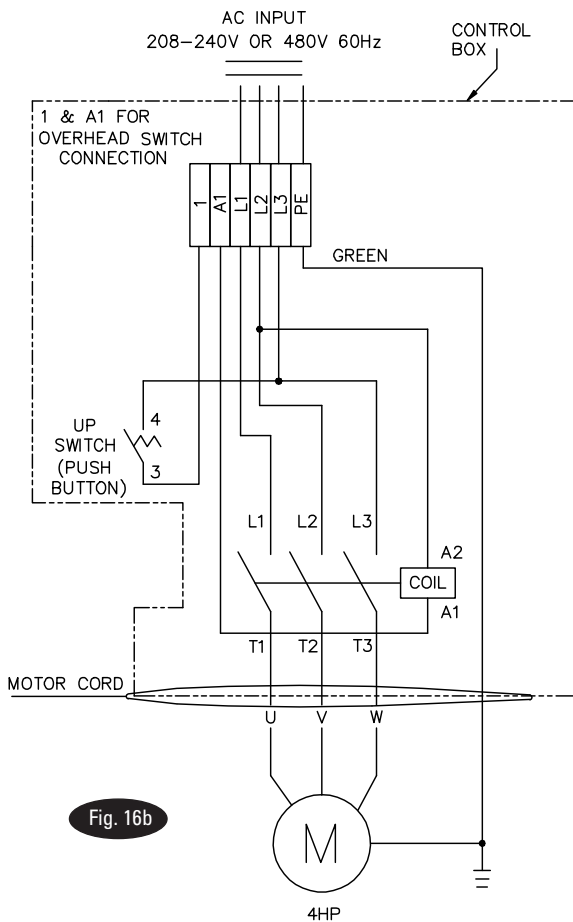


Fig. 16b



**15. Oil Filling & Bleeding:** Use Dexron III ATF, or Hydraulic Fluid that meets ISO 32 specifications. Remove fill-breather cap, Fig. 8a. Pour in (8) quarts of fluid. Start unit, raise lift about 2 ft. Open cylinder bleeders approximately 2 turns, Fig. 9a.

Close bleeders when fluid streams. Torque values for the bleeders are 15 ft. lb. minimum and 20 ft lb. maximum. Fully lower lift. Add more fluid until it reaches the MIN \_\_\_\_\_ mark on the tank. Replace fill-breather cap.

**CAUTION** If fill-breather cap is lost or broken, order replacement. Reservoir must be vented.

**16. Overhead switch:** Check overhead switch assembly to assure that switch bar is depressing switch plunger sufficiently to actuate the switch. The overhead switch is wired normally open, see Fig. 15, Fig. 16, and Fig. 16b. Lift will not operate until weight of switch bar is depressing switch plunger. Verify that Power Unit stops working when switch bar is raised, and restarts when the bar is released.

**17. Arms & Restraints:** Before installing arms, raise carriages to a convenient height. Grease swivel arm pins and holes with Lithium grease. Slide arm into yoke, Fig. 17a. Install 1-3/4" diameter arm pin(s), Fig. 17a.

After installing arms and pins, install arm Restraint Gears as follows: Install Restraint Gear onto arm clevis, as shown, Fig. 17b. Ensure side of gear marked **TOP** is facing upward, Fig. 17b.

**NOTE: TOP is stamped on top side of gear. You may need to pull up on the pin-ring to allow enough room to install Restraint Gear.**

Then, install the (2) 3/8"-16NC x 1-1/2" HHCS (8 total for all 4 arms) and 3/8" Spring Lockwashers into the gear and arm, but do not tighten. Reference Fig. 17c, Fig. 18, and Fig. 19.

Torque the Restraint Gear bolts to 30-34 ft.-lbs.

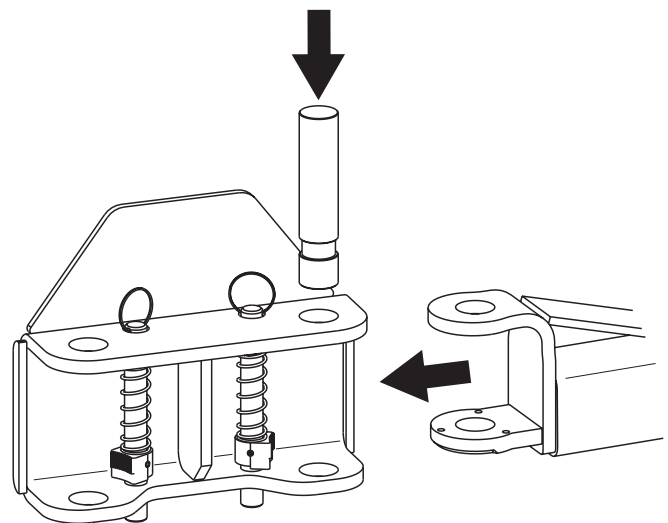


Fig. 17a

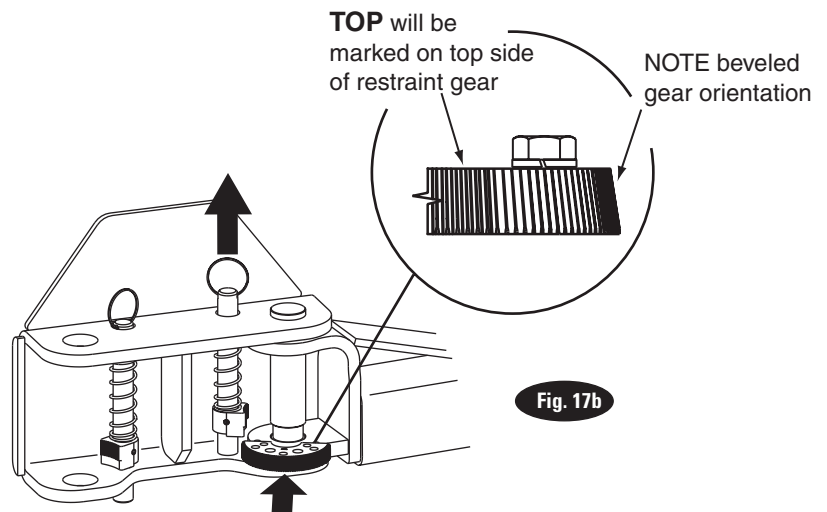


Fig. 17b

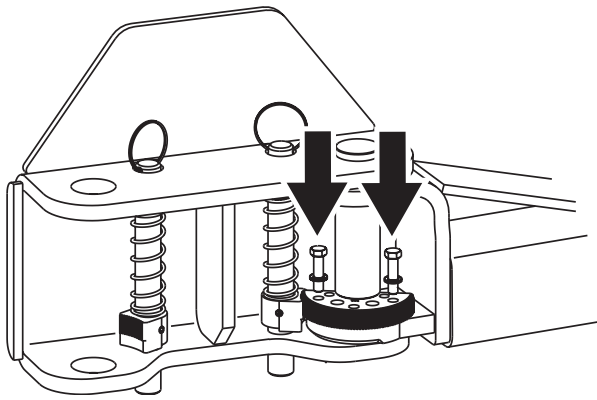


Fig. 17c

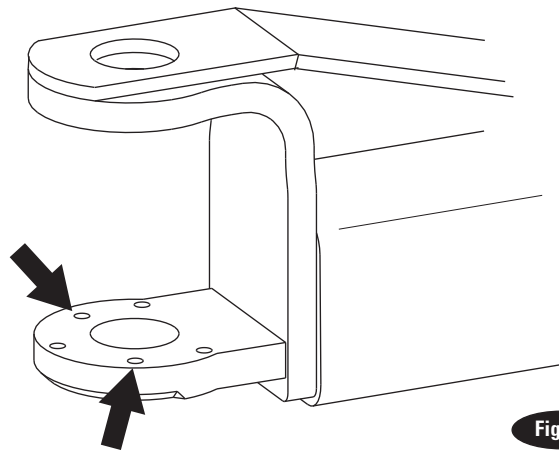


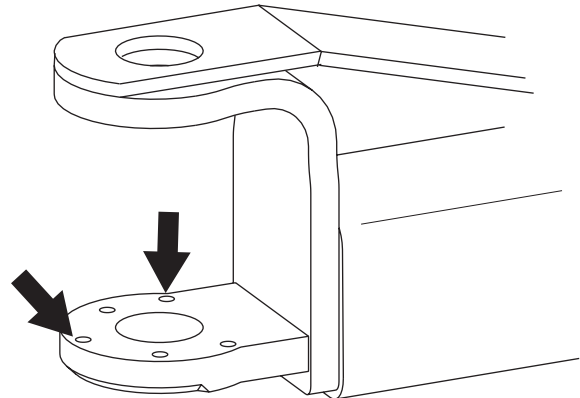
Fig. 18

DO NOT use holes marked with arrows.

**NOTE:** To check operation of arm restraints, raise carriage 1" min. from full down position. Pull up on pin-ring and adjust arms to desired position. To engage restraint, let pin-ring down allowing gear teeth to mesh together. It may be necessary to rotate arm slightly to engage gear teeth.

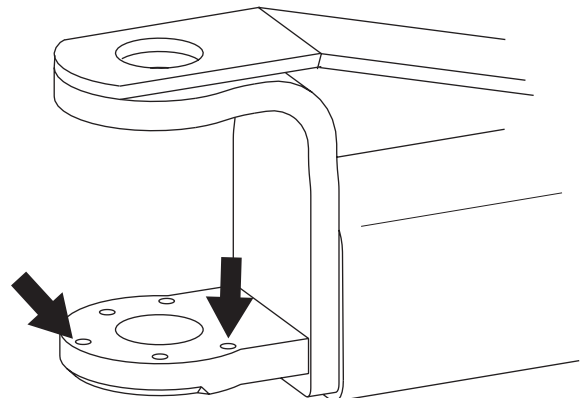
**NOTE:** Pin & Ring, Spring, & Gear Block are all pre-assembled.

**NOTE:** Once arm is installed in yoke, pull up actuator pin and swing arm fully around, being sure that the Restraint Gear and Gear Block always stay aligned. If they do not stay aligned, remove restraint gear and install in the opposite position.



Use holes marked with arrow for Right Front and Left Rear.

Fig. 19



Use holes marked with arrow for Left Front and Right Rear.

**18. Installation of Rack for Adapter Extensions:** Install racks as shown, Fig. 20, using 5/16"-18NC x 3/8" PHMS.

**19. Door Bumper Installation:**

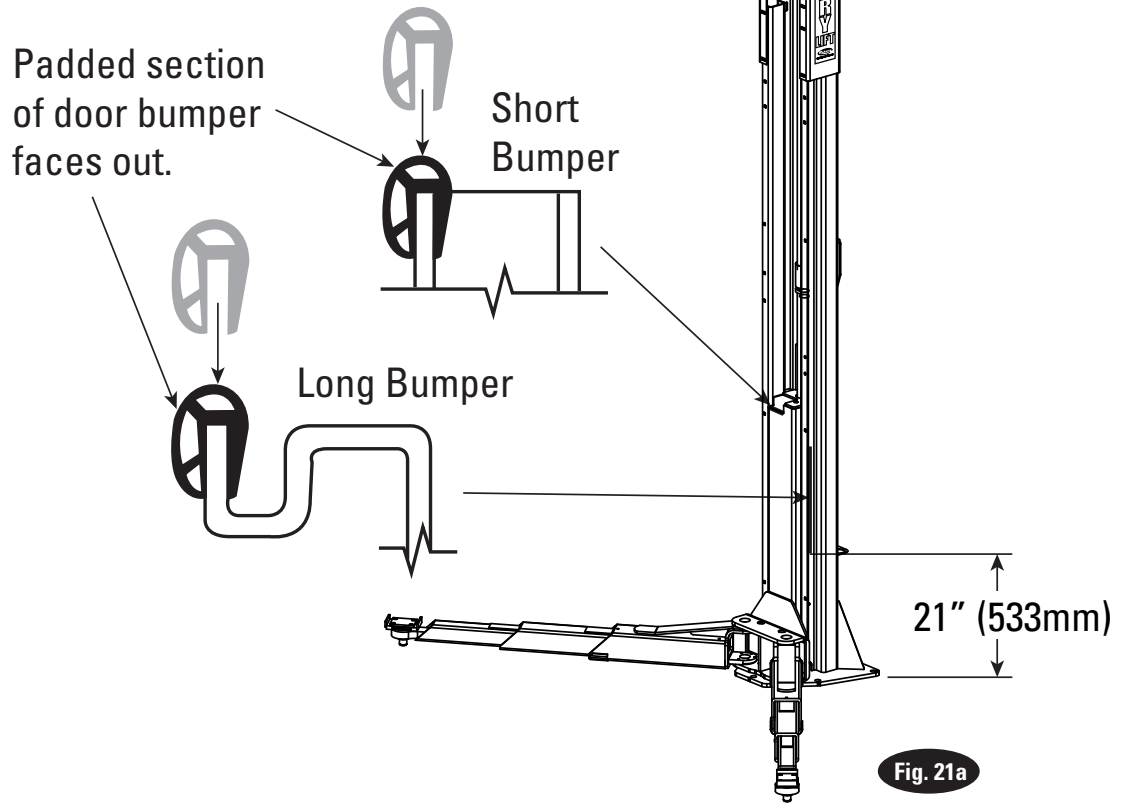
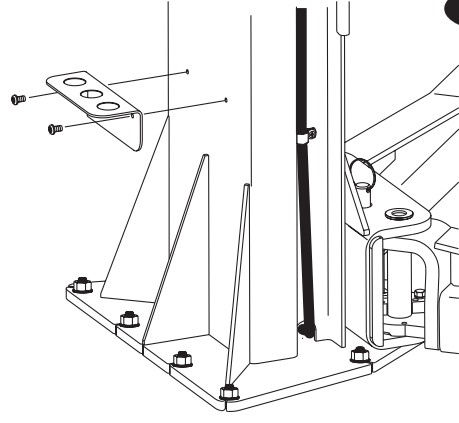
- 1) Press long bumper on column edge, Fig. 21a.
- 2) Press short bumper on top edge of carriage tube, Fig. 21a.

**20. Latch Cable Adjustment:**

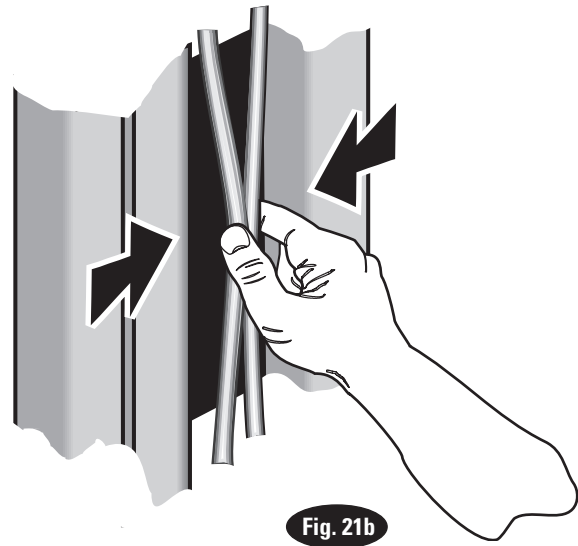
- A) Check to make sure the latch will properly engage and disengage. **Slowly** release the latch handle. A 1/8" gap between the top of the latch dog and the column is allowable.
- B) When raising, listen to latches to be sure that both latch dogs fall into latch slots. If they do not, loosen clamp and adjust tension as necessary.
- C) Install left latch cover using 5/16-18NC x 3/8" lg PHMS.

**21. Pressure Test:** Run lift to full rise and keep motor running for 5 seconds. Stop and check all hose connections. Tighten or reseal if required. Repeat air bleeding of cylinders.

Fig. 20



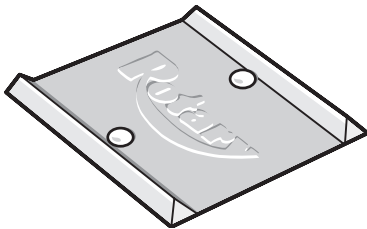
**22. Equalizer Cable Adjustments:** Raise lift to check equalizer cable tension. Below carriage, grasp adjacent cables between thumb and forefinger, with about 15 lbs. effort you should just pull the cables together. Adjust at upper tie-offs Fig. 21b.



**23. Latch Release Decal:** Install latch release decal on cover above latch release handle, Fig. 22.

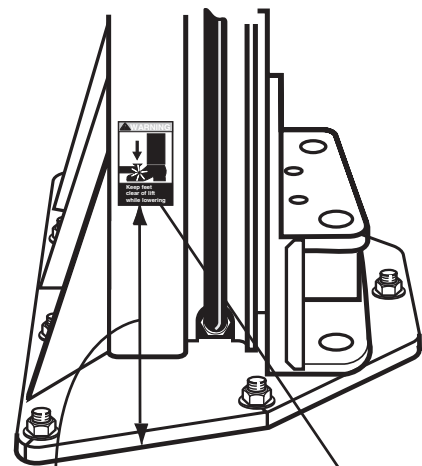
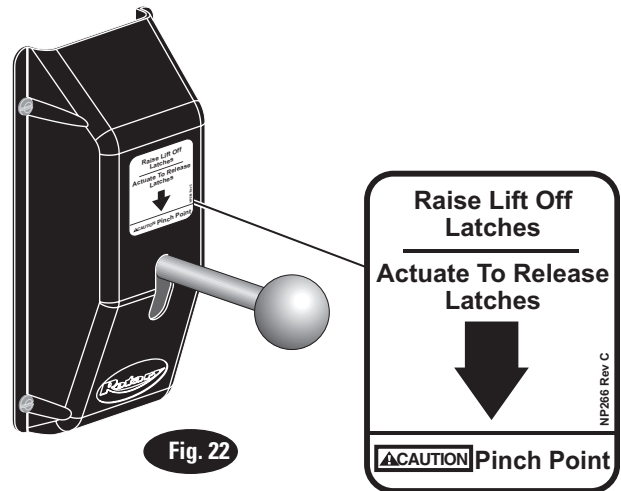
**24. Pinch Point Decal Location:** Install enclosed pinch point decals. Place (1) decal on each column, Fig. 23.

**25. Wheel Spotting Dish:** Position wheel spotting dish as illustrated in Fig. 1. Drill (2) 3/8" holes 2-1/2" deep in concrete floor using holes in wheel spotting dish as guide. Drive both anchors, provided, into concrete to secure dish.



**26. Upon completion** of the assembly of the lift, the lift is to be operated to assure proper function. Observe for locks operating in all locking positions, each side lifts equally, hydraulics do not leak, all electrical controls function as labeled, all pneumatics are functional and leak free, ramps rotate freely (if applicable), and proper clearances with all items in bay have been maintained.

Operate the lift with a typical vehicle and observe to assure the same items for proper functioning.



Place WARNING decal a minimum of 8" from the bottom of the decal to the ground.





## NOTES



**Installer:** Please return this booklet to literature package, and give to lift owner/operator.

**Thank You**

***Trained Operators and Regular Maintenance Ensures Satisfactory Performance of Your Lift.***

**Contact Your Nearest Authorized Rotary Parts Distributor for Genuine Rotary Replacement Parts. See Literature Package for Parts Breakdown.**

<b>DATE</b>	<b>REV.</b>	<b>CHANGE MADE</b>
11/04/03	-	New (500 Series) instructions. New Locking Latch Cable Routing, new arm pin, new restraint gears, new hose clamp attachment hardware.
04/07/04	A	Added Hummer and Sprinter lift models to this standard instruction.
05/05/04	B/C	Revisions not used.
05/05/04	D	Removed steel elbow from figures.
06/17/04	E	Made plan views/graphics easier to identify.
08/02/04	F	Updated 500 and 5W0 series tie bar graphics.
11/08/04	G	Added new actuator graphics and UL Verbiage.
1/13/05	H	Updated graphic on page 3 - Fig. 4 & 6.
1/16/06	I	Skipped Letter Not Used.
1/16/06	J	Updated model sequence to show standard installation first.
12/15/06	K	Added 4HP 1 Phase Power Unit.
01/15/07	L	Updated motor wiring in the electrical section and added torque values to cylinder bleeders.
09/11/07	M	Updated drum switch wiring.
06/02/08	N	Added 700 Series Lifts to manual.
06/14/10	P	Changed lift illustrations to show 3-stage arms and updated 3 Phase motor graphics.
02/17/11	Q	Updated tie bar specifications
11/6/11	R	Updated concrete requirements
4/3/12	T	Updated power unit hardware
11/12/12	U	Torque 110 ft lbs. was 150 ft lbs.
3/25/14	V	Identify metal or plastic hose clamps
2/13/15	W	Add final check information, item #26
2/27/15	X	Add 3 phase control box.
3/11/15	Y	Add EH1 14'-8", EH2 15'-8", and EH3 16'-8" to overhead height.
1/19/17	Z	Update image for low and high motor connection. Update anchoring requirements table.

**Rotary World Headquarters**

2700 Lanier Drive  
Madison, IN 47250, USA  
www.rotarylif.com

**North America Contact Information**

Tech. Support:  
p 800.445.5438  
f 800.578.5438  
e userlink@rotarylif.com  
Sales:  
p 800.640.5438  
f 800.578.5438  
e userlink@rotarylif.com

**World Wide Contact Information**

World Headquarters/USA: 1.812.273.1622  
Canada: 1.905.812.9920  
European Headquarters/Germany: +49.771.9233.0  
United Kingdom: +44.178.747.7711  
Australasia: +60.3.7660.0285  
Latin America / Caribbean: +54.3488.431.608  
Middle East / Northern Africa: +49.771.9233.0

**© Vehicle Service Group<sup>SM</sup>**

Printed in U.S.A., All Rights Reserved. Unless otherwise indicated, ROTARY, and all other trademarks are property of Dover Corporation and its affiliates.

