



World Leader in Lift Systems

Model: SPO12

SPO12-10 thru SPO12-12 & SPO12-20 thru SPO12-28 Series

Two Post Surface Mounted

Swing Arm Frame Engaging Lift

Capacity: 12,000 lbs. (3,000 lbs. per arm)

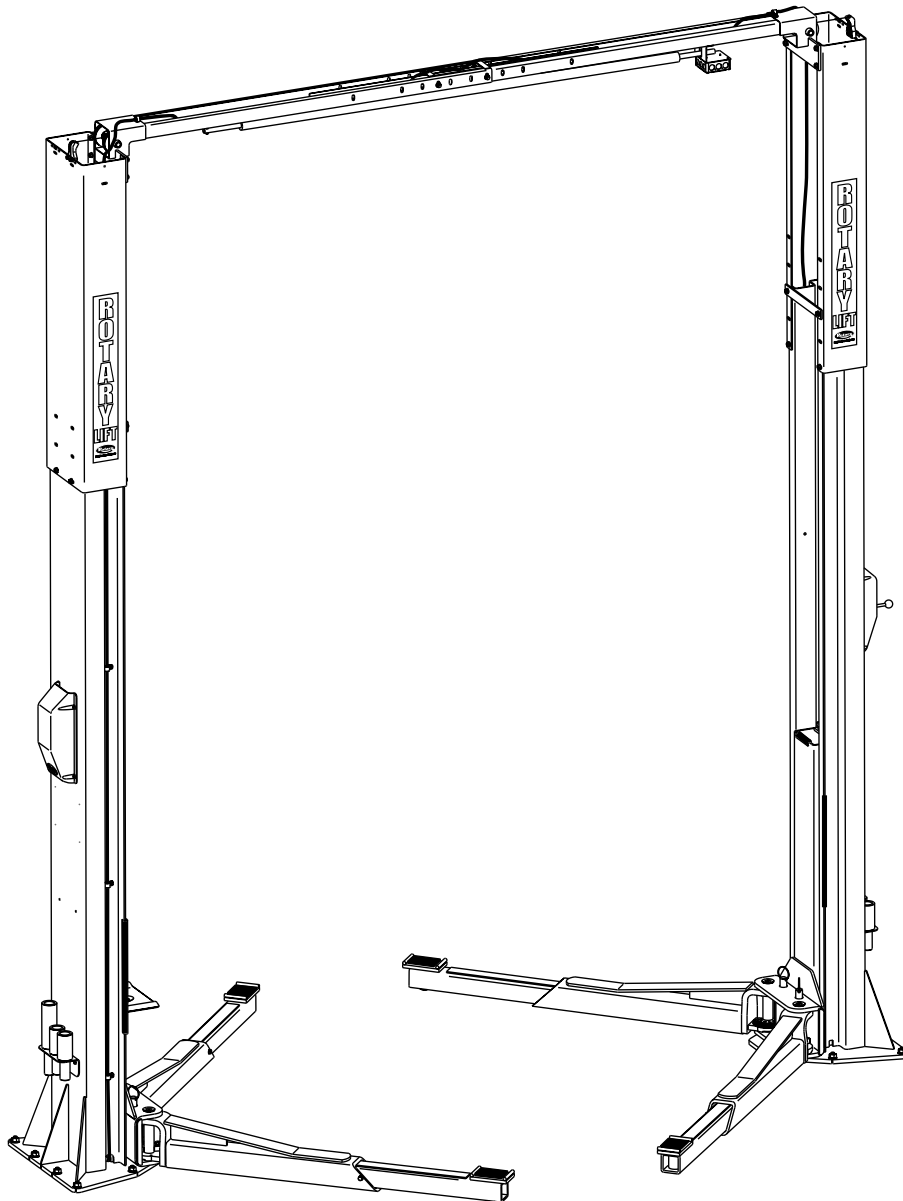

ROTARY LIFT

INSTALLATION INSTRUCTIONS

INSTALLATION INSTRUCTIONS

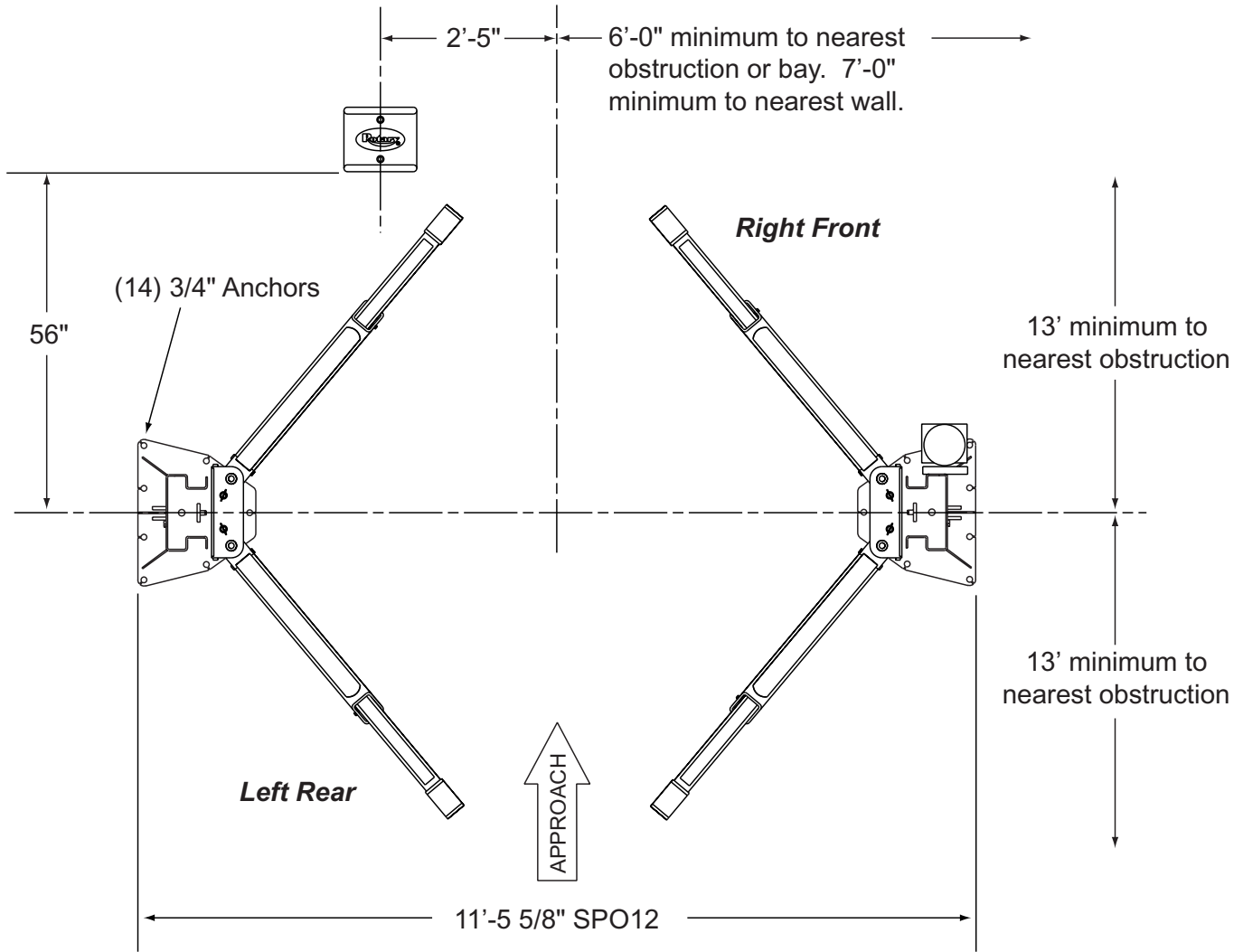

Fig. 1

1. Lift Location: Use architects plan when available to locate lift. Fig. 1 shows dimensions of a typical bay layout.

2. Lift Height: See Fig. 4 for overall lift height of each specific lift model. Add 1" min. to overall height to lowest obstruction.

⚠WARNING DO NOT install this lift in a pit or depression due to fire or explosion risks.

3. Lift Setting: Position columns in bay using dimensions shown in Fig. 1. Place column with power unit mounting bracket on vehicle passenger side of lift. Both column base plate backs must be square on center line of lift. Notches are cut into each base plate to indicate center line of lift.

Use appropriate equipment to raise carriage to first latch position. Be sure locking latch is securely engaged.

Concrete and Anchoring: Concrete shall have a compression strength of at least 3,000 PSI and a minimum thickness of 4-1/4" in order to achieve a minimum anchor embedment of 3-1/4".

Drill (14) 3/4" dia. holes in concrete floor using holes in column base plate as a guide. See diagrams for hole depth, hole spacing, and edge distance requirements.

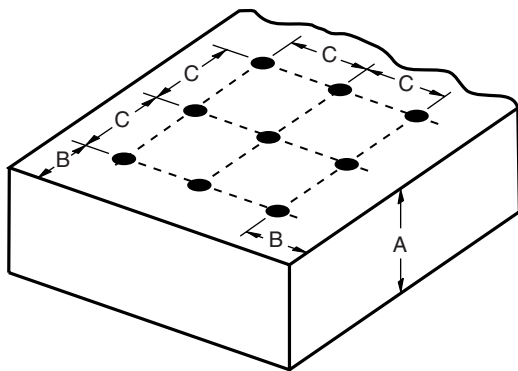

- A) Concrete Thickness & Hole Depth (4-1/4")
- B) Edge Distance (4-3/4")
- C) Hole Spacing (6-1/2")

⚠CAUTION DO NOT install on asphalt or other similar unstable surfaces. Columns are supported only by anchors in floor.

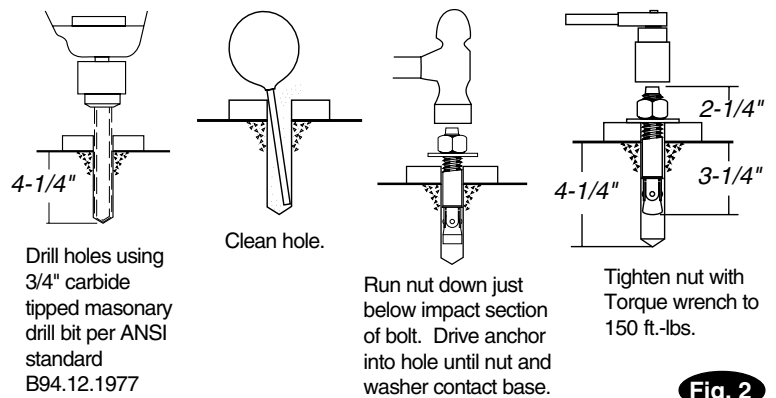

Fig. 2

Installation torque of 150 ft.-lbs. is required for all anchor bolts.

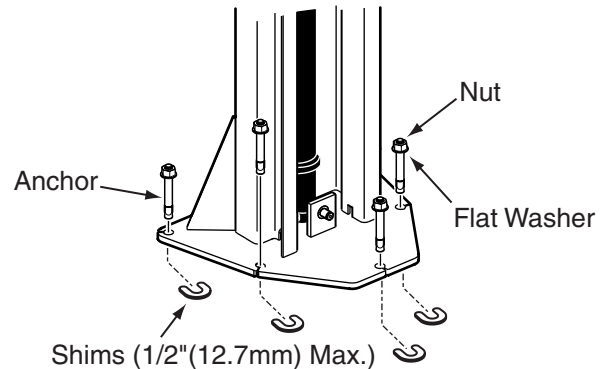

Fig. 3

NOTE: If more than 2 horse shoe shims are used at any of the column anchor bolts, pack non-shrink grout under the unsupported area of the column base. Insure shims are held tightly between the baseplate and floor after torquing anchors.

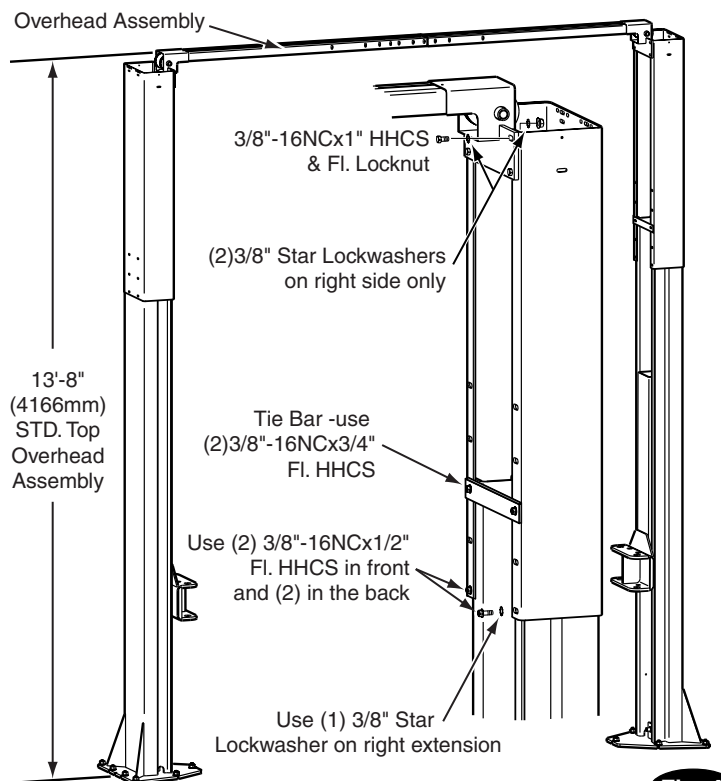

Fig. 4

IMPORTANT: All star washers are to be mounted on the right side column to ensure grounding of overhead limit switch. Star washers are not needed when mounting to left side column. Notice the column extension mounting, Fig. 4 and overhead limit switch mounting as well in Fig. 4 & Fig. 6.

4. IMPORTANT: Using the horse shoe shims provided, shim each column base until each column is plumb. If one column has to be elevated to match the plane of the other column, full size base shim plates should be used (Reference Shim Kit). Recheck columns for plumb. Tighten anchor bolts to an installation torque of 150 ft-lbs. Shim thickness **MUST NOT** exceed 1/2" when using the 5-1/2" long anchors provided with the lift.

If anchors do not tighten to 150 ft-lbs. installation torque, replace concrete under each column base with a 4' x 4' x 6" thick 3000 PSI minimum concrete pad keyed under and flush with the top of existing floor. Let concrete cure before installing lifts and anchor.

5. Latch Cable Guide: While still on the ground, install latch cable guides to column extensions with (4) 1/4"-20NC x 1" lg. HHCS and Flanged Locknuts, Fig.5 & Fig. 9d.

NOTE: Latch cable guide must be toward approach side of the column extension. Coat the cable contact surface with a light grease such as "TUFOIL".

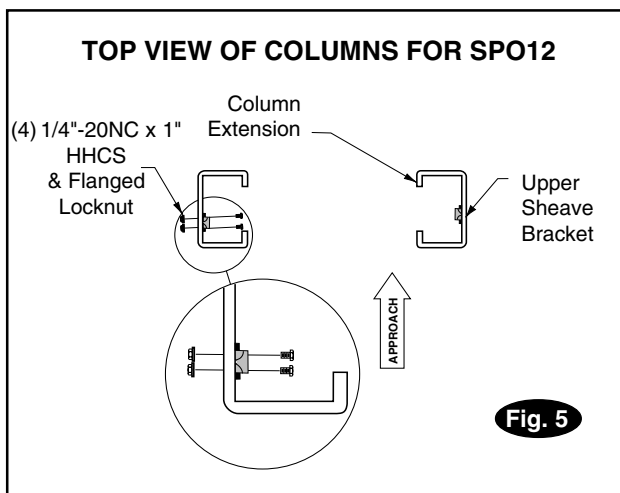

6. Column Extensions: Install column extensions using (4) 3/8"-16NC x 1/2" lg. Flanged HHCS, Fig. 4. Use (2) 3/8"-16NC x 3/4" lg. Flanged HHCS to attach the tie bar and the column extension together at the column's uppermost holes, Fig. 4. The tie bar is positioned on the outside of the column extension. Adjust the column extensions plumb.

7. Overhead Assembly: Adjust overhead to 114" between centerline of sheave pins, Fig. 6. Install (4) 3/8"-16NC x 3/4" Flanged HHCS & Flanged Locknuts, do not tighten. Install overhead stiffener angle inside center of overhead using (4) 3/8"-16NC x 1" Flanged HHCS and Flanged Locknuts, see Fig. 6. Mount switch assembly towards power unit column as shown, using (2) 1/4"-20NC x 3/4" lg. HHCS, nuts and 1/4" Star Washers. Insert 1/4"-20NC x 2" HHCS through pivot hole in end of switch bar. Insert opposite end of bar through slot in switch mounting bracket. Then secure Hex bolt and switch bar to overhead as shown, using 3/4" spacer and Locknut. Tighten Hex bolt leaving 1/16" gap between the spacer and the overhead assembly.

8. Overhead: Install overhead assembly to column extensions with (2) star washers and (8) 3/8"-16NC x 1" Flanged HHCS and Flanged Locknuts, Fig. 4. Tighten bolts at center of overhead assembly.

9. Power Unit: First install (1) star washer onto one of the (4) 5/16"-18NC x 1-1/2" HHCS, Fig. 7. This is very important for grounding. Put the (4) 5/16"-18NC x 1-1/2" HHCS thru holes in power unit bracket using push-nuts to hold in place. Mount unit with motor up to column bracket and install lock washers and nuts. Install and hand tighten Branch Tee to pump until O-ring is seated. Then tighten Locknut to 35-40 ft.-lbs, and connect supply hoses to Tee, Fig. 7.

NOTE: Over tightening Locknut may tear O-ring.

10. Hoses: Clean adapters and hose. Inspect all threads for damage and hose ends to be sure they are crimped. Install hose and hose clamps, Fig. 9A.

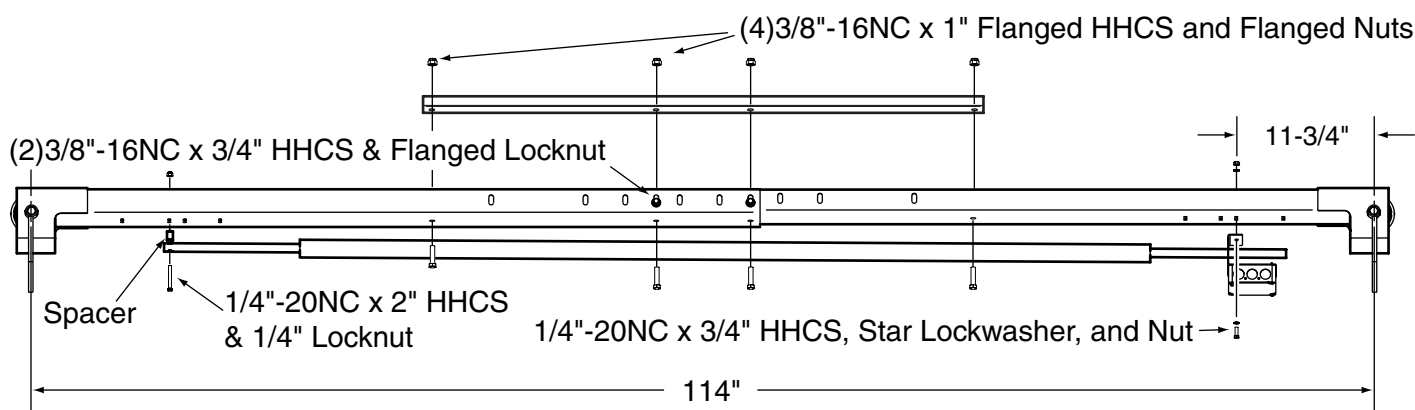

Fig. 6

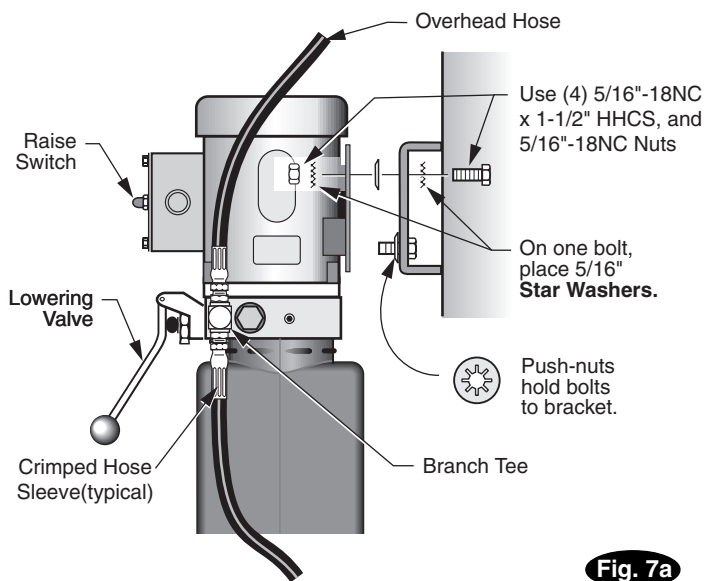

Fig. 7a

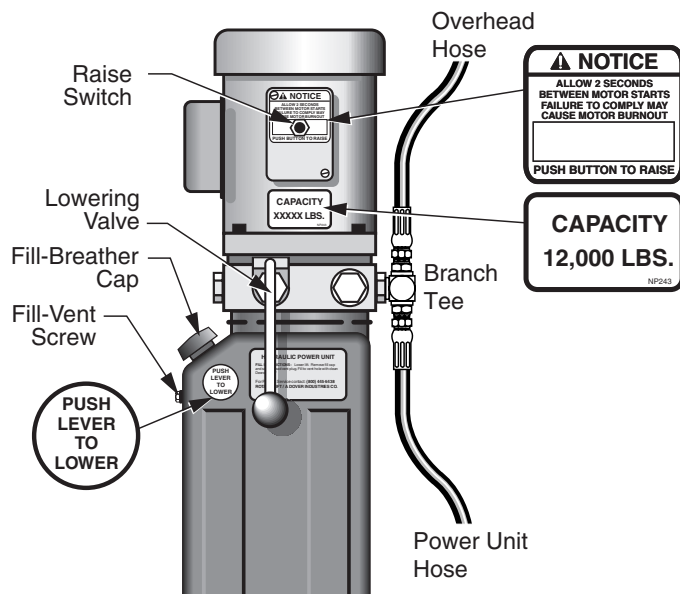
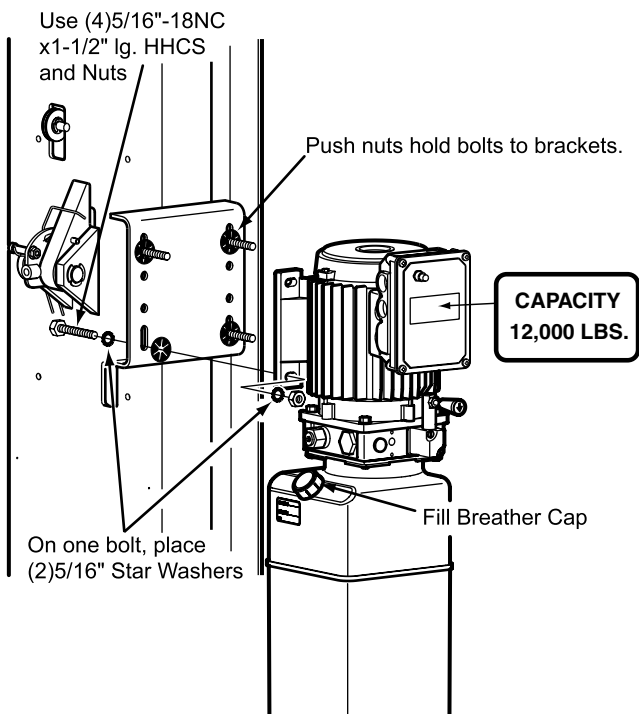

Fig. 8



FOR 3 PHASE POWER UNITS ONLY:
Attach Control Plate to Motor using (4)
5mm-.80 x 8mm lg. Flat Head Machine Screws

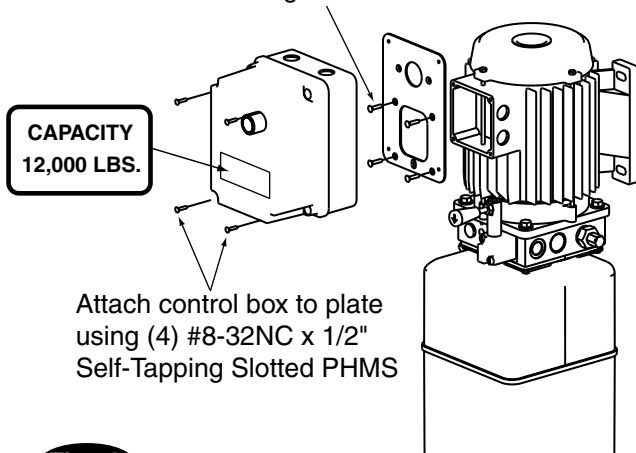

Fig. 7b

Flared Fittings Tightening Procedure

1. Screw the fittings together finger tight. Then, using the proper size wrench, rotate the fitting 2-1/2 hex flats (1/3 of a revolution).
2. Back the fitting off one full turn.
3. Again tighten the fittings finger tight; then using a wrench, rotate the fitting 2-1/2 hex flats (1/3 revolution). This will complete the tightening procedure and develop a pressure tight seal.

Adapter & Hose Installation

1. Install Pc. (2) with hose clamps, on power unit column side connecting it to the cylinder (1) first.
2. Install Pc. (3) with hose clamps starting at left column cylinder (5) and working toward the right column. All excess hose should be at bends & inside overhead assembly.
3. Install Pc. (4) into power unit.
4. Connect Pc. (2) & Pc. (3) to Tee (4).

NOTE: Route Power Unit hose inside columns using slots provided at column base, Fig. 9b. Route Overhead Hose in column channel on outside of column, Fig. 9c. Overhead hose goes over top end of overhead assembly, Fig. 9d.

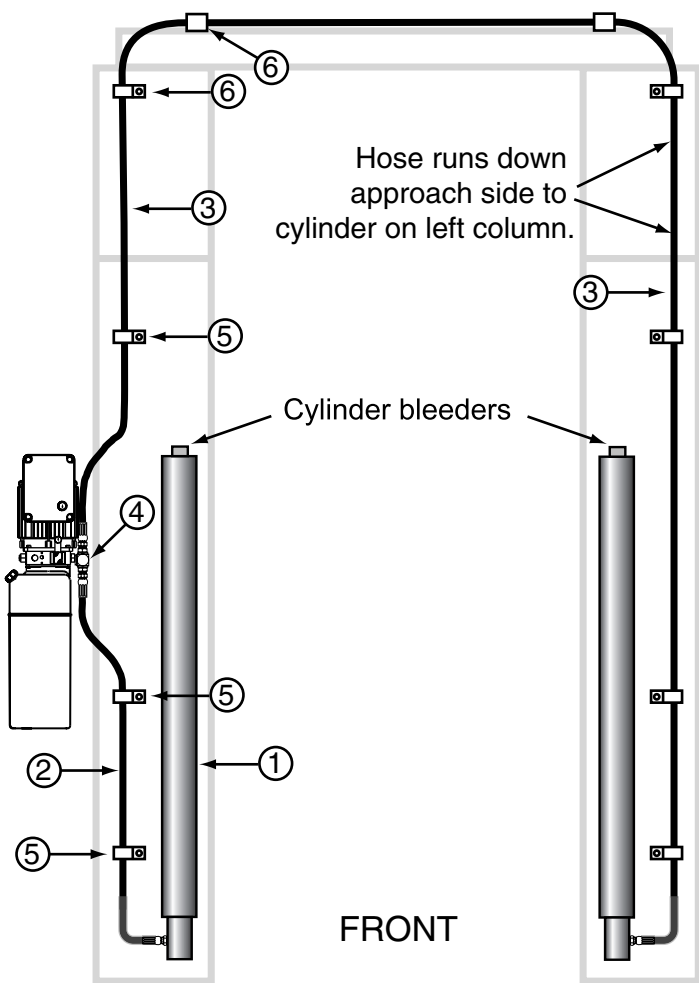

Fig. 9a

ITEM	QTY.	DESCRIPTION
1	2	Hydraulic Cylinder
2	1	Power Unit Hose
3	1	Overhead Hose
4	1	Branch Tee
5	6	Hose Clips
5	6	5/16-18NC x 3/8" lg. PHMS
6	4	Hose Clips
6	4	#12 Type B x 1/2" lg. Slotted HexWasher Head Screw

NOTE: Overhead hose crosses and runs down approach side of left column to cylinder.

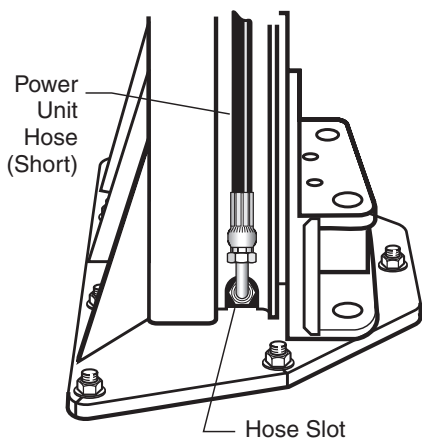

Fig. 9b

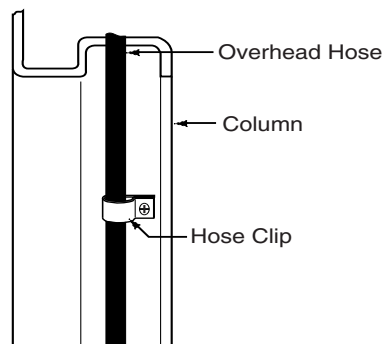

Fig. 9c

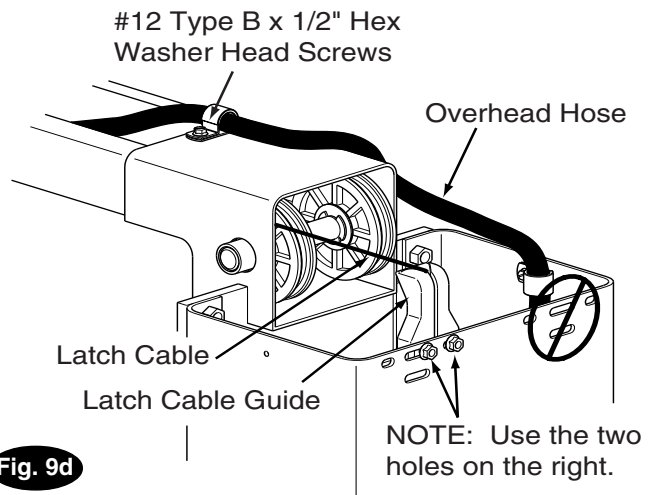

Fig. 9d

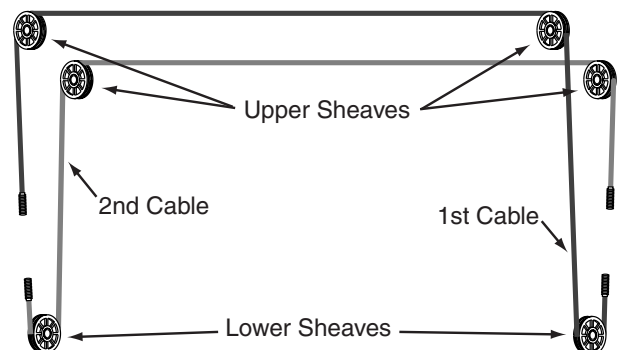

Fig. 10a

11. Equalizing Cables

- Refer to Fig. 10a for the general cable arrangement. First, run a cable end up through the small hole in the lower tie-off plate. Fig. 10b.
- Push the cable up until the stud is out of the carriage top opening.
- Run a nylon insert locknut onto the cable stud so 1/2" (13mm) of the stud extends out of the locknut.
- Pull the cable back down. Fig. 10b
- Run cable around the lower sheave, then up and around overhead sheave and across and down to the opposite carriage. Fig. 10a.
- Fasten the cable end to the carriage upper tie-off bracket. Tighten the locknut enough to apply light tension to the cable.
- Repeat procedure for the second cable. Complete lift assembly. Adjust the tension of both cables during the final adjustments in Paragraph 20.

12. Locking Latch Cable

- Slip loop end of cable over end of shoulder screw on right side latch control plate, Fig. 11.

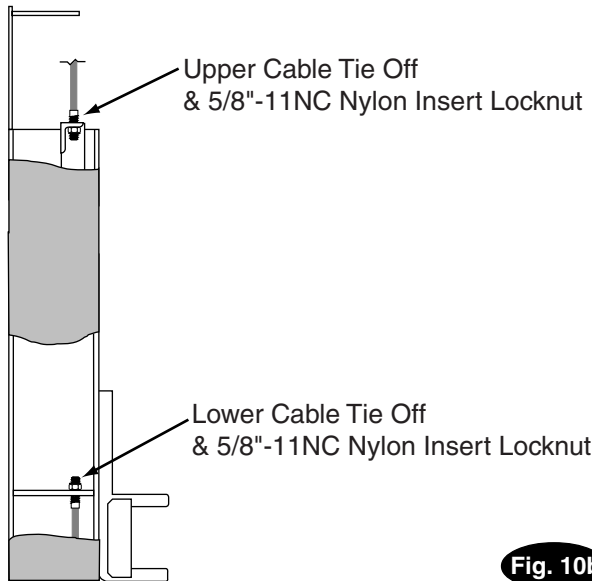

Fig. 10b

- B) Feed the other end of the cable through the latch cable sheave slot making sure that the cable is running under the bottom side of the latch cable sheave and inside the right column, Fig. 11.

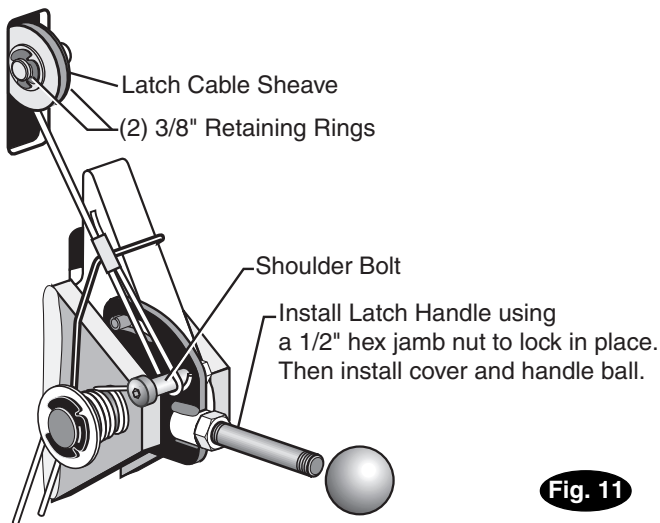

Fig. 11

- C) Route cable up inside column and through the latch cable guide, Fig. 12 & Fig. 9d.
 D) Continue routing cable to the left column latch cable guide, Fig. 12 & Fig. 9d, routing the cable through the top of the left column latch cable guide, Fig. 9d.
 E) Bring the cable down inside the left column and feed the end of the cable through the latch cable sheave slot so that the cable is now back outside the column, Fig. 13.
 F) Route cable under the bottom side of the latch cable sheave.
 G) At this point you **MUST** install the latch handle, jam nut, and right column latch cover Fig. 14 & Fig. 11. Install latch handle ball, Fig. 11.
 H) Insert cable in cable clamp along one side, loop around shoulder screw and back down, inserting cable along other side of cable clamp, Fig. 13. Place top back on clamp, barely tightening.

- D) Next, pull the control plate down, Fig. 13, to eliminate any clearance between the control plate slot and the latch dog pin, Fig. 12.
 J) Using Pliers, pull cable tight and secure the clamp close to the shoulder screw. Tighten clamp.

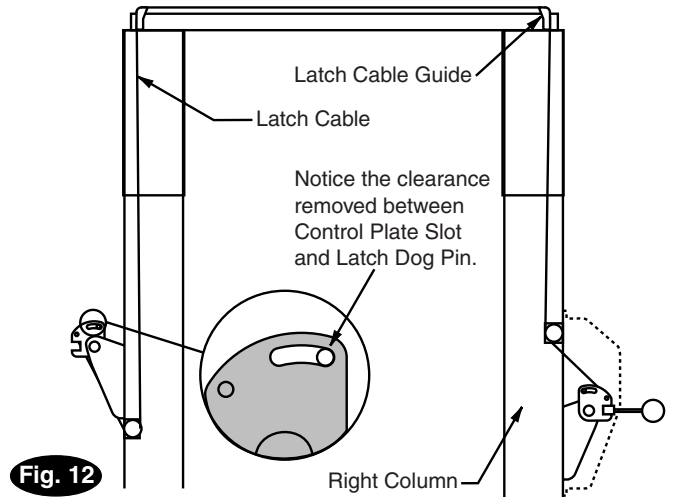

Fig. 12

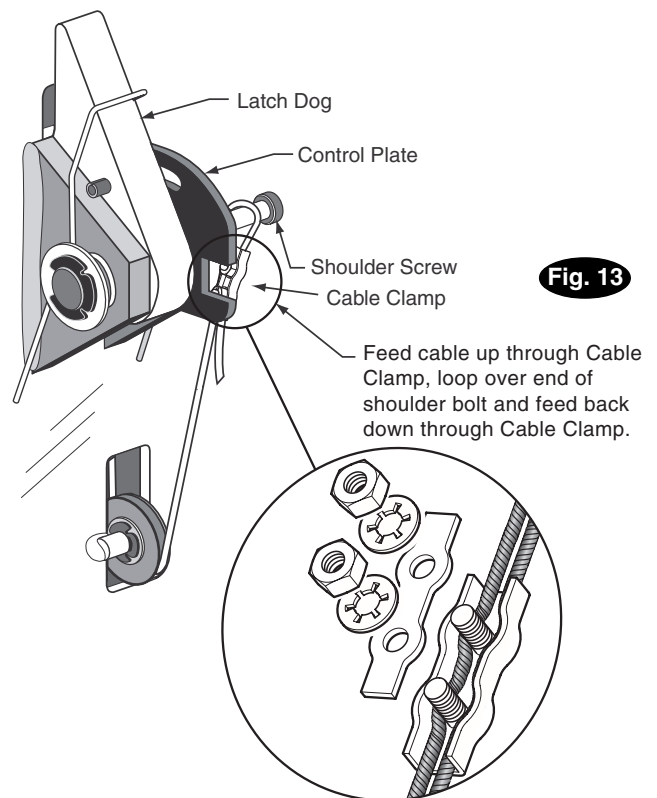

Fig. 13

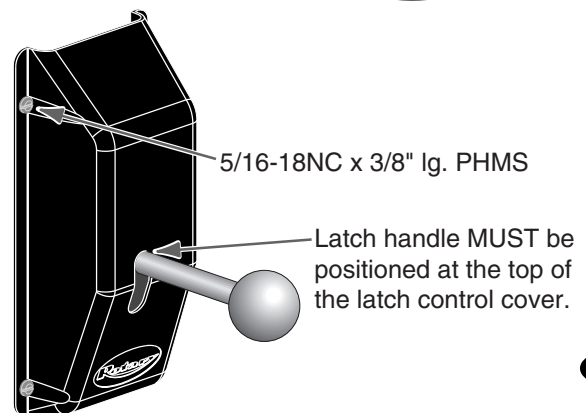

Fig. 14

Single Phase Fenner Power Unit

MOTOR OPERATING DATA - SINGLE PHASE		
LINE VOLTAGE	60 HZ	RUNNING MOTOR VOLTAGE RANGE
208 - 230 Volts	60 HZ	197 - 253 Volts

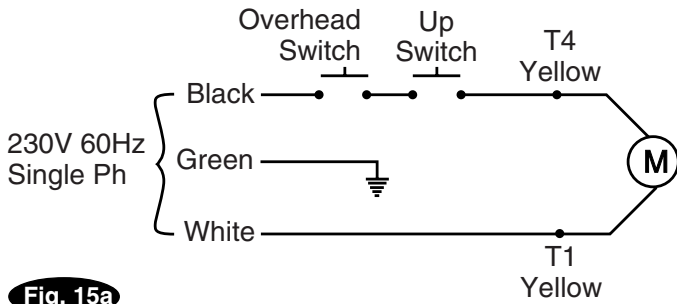
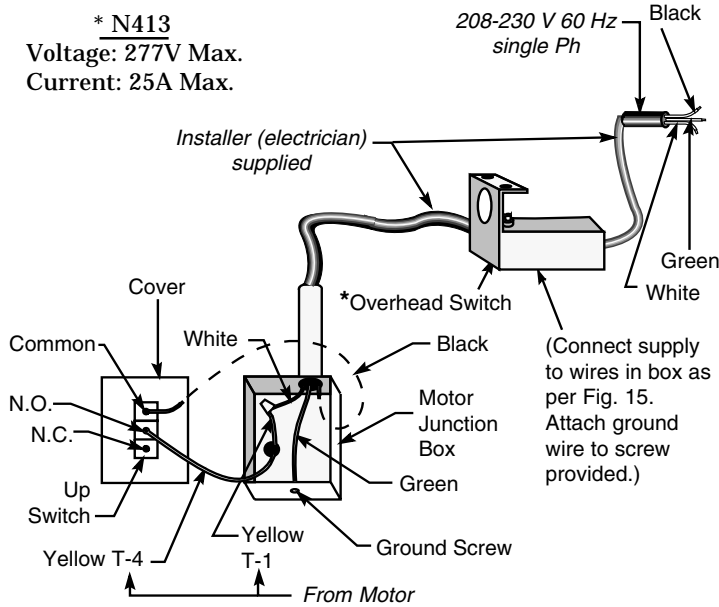

Fig. 15a

* N413
Voltage: 277V Max.
Current: 25A Max.



13. Overhead switch: Check overhead switch assembly to assure that switch bar is depressing switch plunger sufficiently to actuate the switch. The overhead switch is wired normally open, see Fig. 15a & 15b. Lift will not operate until weight of switch bar is depressing switch plunger.

14. Electrical: Have a certified electrician run 208-230 volt single phase 60Hz. power supply to motor, Fig. 15a & 15b. Size wire for 25 amp circuit. See Motor Operating Data Table.

CAUTION Never operate the motor on line voltage less than 208V. Motor damage may occur.

IMPORTANT: Use separate circuit for each power unit. Protect each circuit with time delay fuse or circuit breaker. For single phase 208-230V, use 25 amp fuse, and three phase use 20 amp fuse. For three phase 460V, use 10 amp fuse. For three phase wiring see Fig. 7a, 16a, & 16b. All wiring must comply with NEC and all local electrical codes.

Note: Standard single phase motor CAN NOT be run on 50Hz. line without a physical change in the motor.

Single Phase Rotary Power Unit

MOTOR OPERATING DATA - SINGLE PHASE		
LINE VOLTAGE	60 HZ	RUNNING MOTOR VOLTAGE RANGE
208 - 230 Volts	60 HZ	197 - 253 Volts

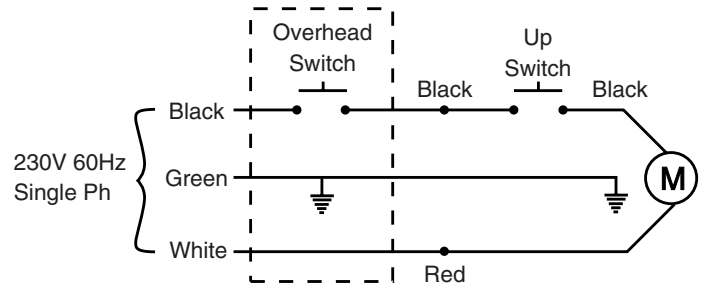
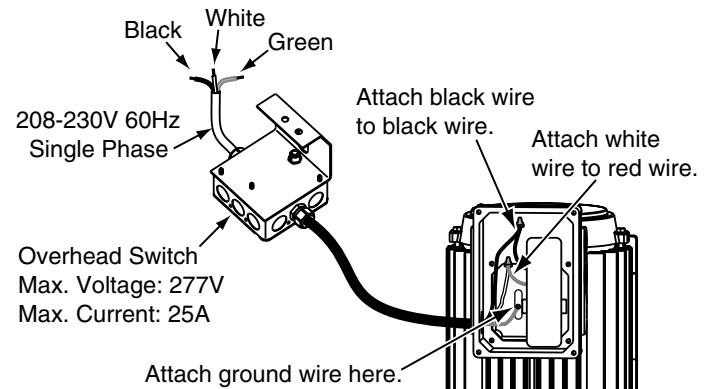

Fig. 15b



Connect supply to wires in box as per Fig. 15. Attach ground wire to screws provided.

Three Phase Rotary Power Unit

MOTOR OPERATING DATA - THREE PHASE		
LINE VOLTAGE		RUNNING MOTOR VOLTAGE RANGE
208 - 230 Volts	60 HZ	197 - 253 Volts
460 Volts	60 HZ	414 - 506 Volts

NOTES:

- Unit not suitable for use in unusual conditions. Contact Rotary for moisture and dust environment duty unit.
- Control Box must be field mounted to power unit.
- Requirements:
Use: FA7162 for 60 Hz. 208V Supply
FA7163 for 60 Hz. 220-240V Supply
FA7164 for 60 Hz. 440-480V or 50 Hz. 400V Supply
FA7165 for 50 Hz. 480V
- *Verify Coil Rating Matches Supply Voltage
- Motor rotation is counter clockwise from top of motor.

LOW VOLTAGE CONNECTION

Fig. 16a

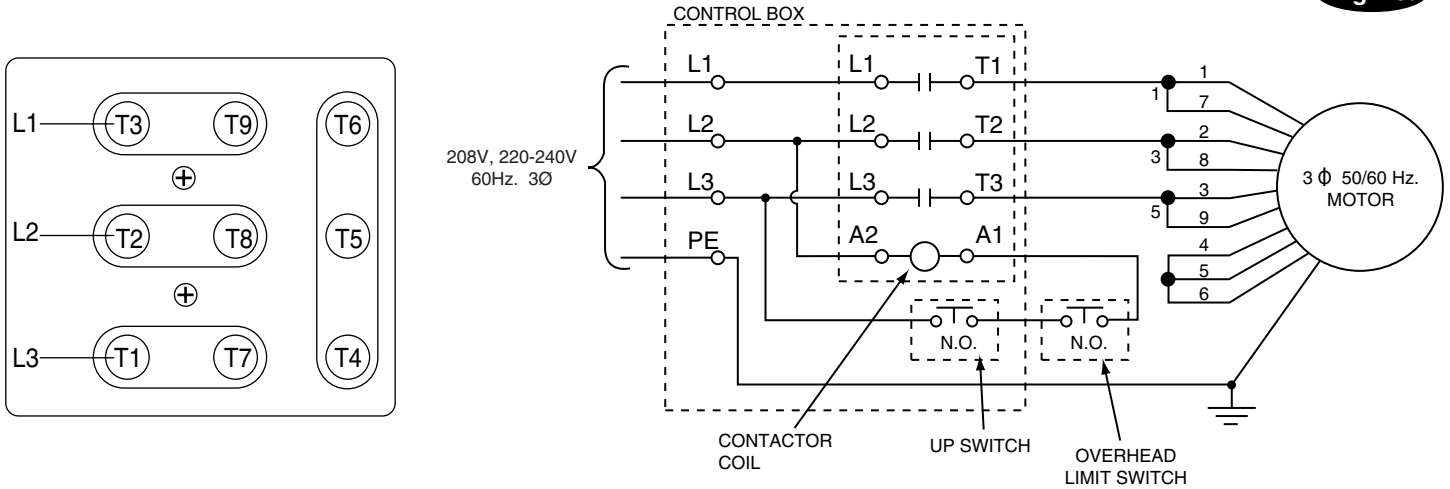

HIGH VOLTAGE CONNECTION

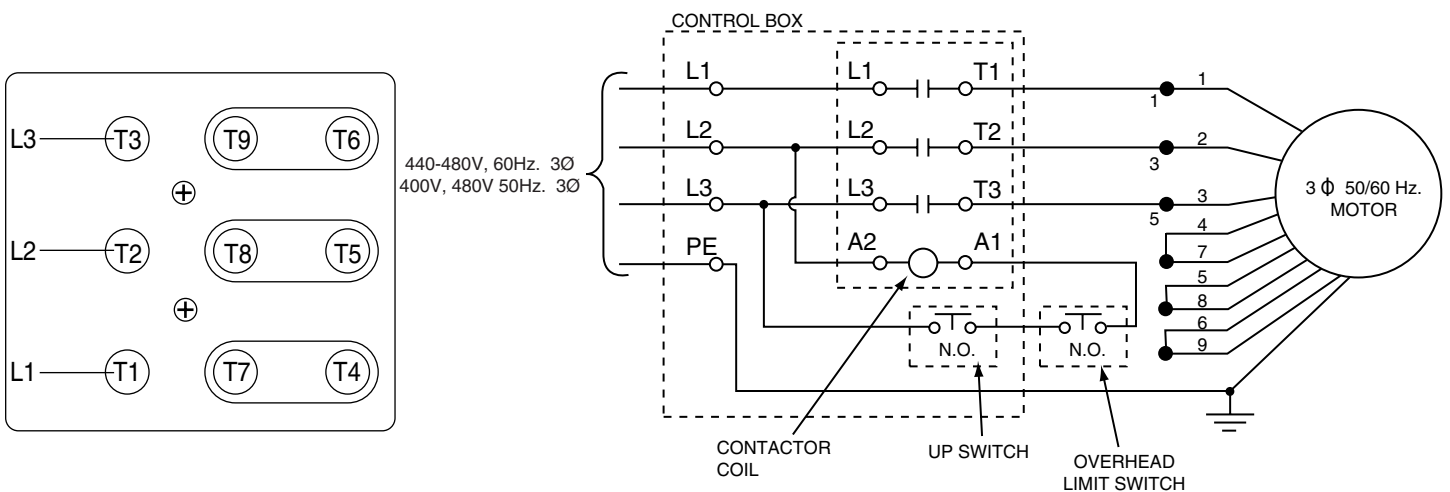

LEGEND	T1	RED	T6	BLACK "T"
	T2	BLUE	T7	BROWN
	T3	WHITE	T8	YELLOW
	T4	BLACK "R"	T9	GREEN
	T5	BLACK "S"		

LEGEND	T1	WHITE	T6	BLACK
	T2	RED	T7	WHITE
	T3	BROWN	T8	RED
	T4	WHITE	T9	BLUE
	T5	RED		

Two different wiring colors were used. Determine appropriate LEGEND.

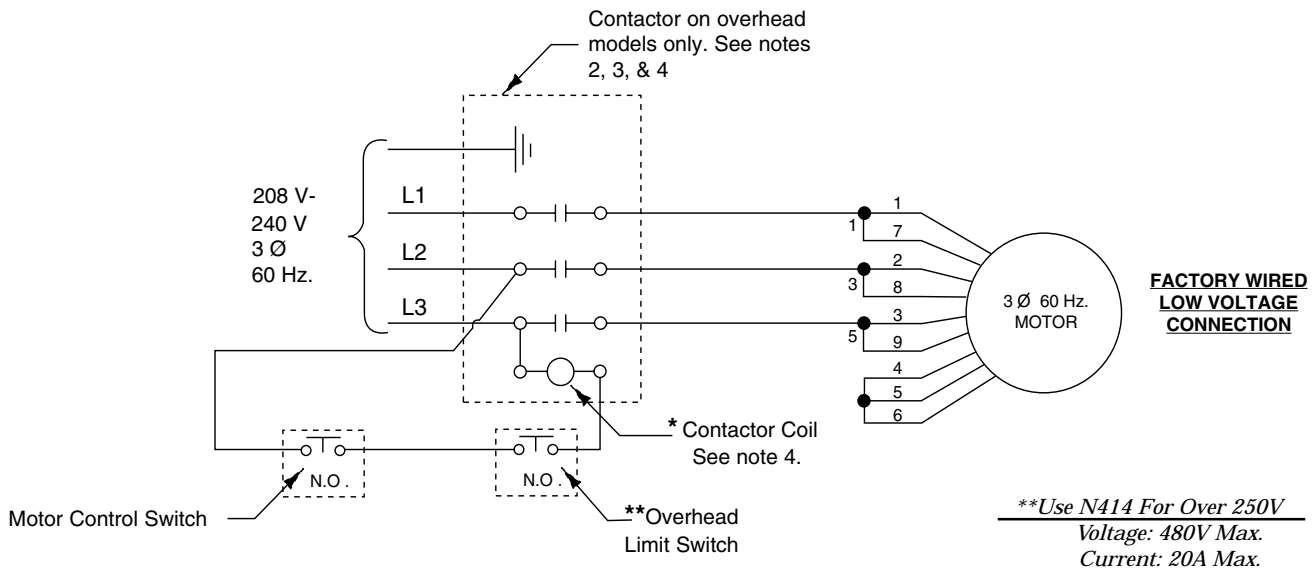

MOTOR OPERATING DATA - THREE PHASE		
LINE VOLTAGE		RUNNING MOTOR VOLTAGE RANGE
208 - 230 Volts	60 HZ	197 - 253 Volts
460 Volts	60 HZ	414 - 506 Volts

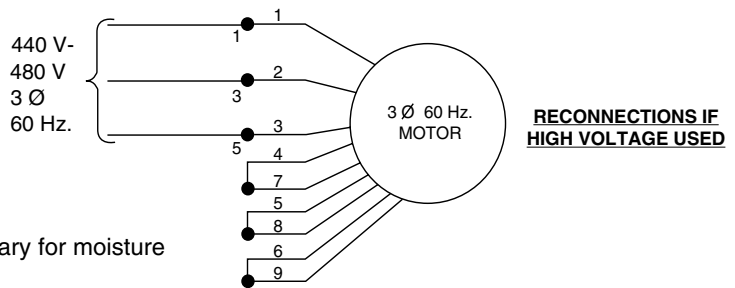

NOTES:

- Unit not suitable for use in unusual conditions. Contact Rotary for moisture and dust environment duty unit.
- Contactor must be field mounted on power unit column.
- Contactor Requirements:
Use: FA7103 for 220-240V Supply
FA787 for 208 Supply
FA7104 for 440-480V Supply
- *Verify Coil Rating Matches Supply Voltage
- Motor rotation is counter clockwise from top of motor.

Fig. 16b

15. Oil Filling & Bleeding: Use Dexron III ATF or ISOVG32 Hydraulic Fluid. Remove fill-breather cap (and fill vent screw for Fenner Power Units), Fig. 8. Pour in (8) quarts of fluid. Start unit, raise lift about 2 ft. Open cylinder bleeders approx. 2 turns, Fig. 9a.

Close when fluid streams. Fully lower lift. For Fenner Power Units, add more fluid until it comes out fill vent hole. All others fill until it reaches the MIN mark on the tank. System capacity is (13) quarts. Replace fill vent screw(for Fenner Power Units) and fill-breather cap.

CAUTION If fill-breather cap is lost or broken, order replacement. Reservoir must be vented.

16. Wheel Spotting Dish: Position wheel spotting dish as illustrated in Fig. 1. Drill (2) 3/8" holes 2-1/2" deep in concrete floor using holes in wheel spotting dish as guide. Drive both anchors, provided, into concrete to secure dish.

17. Arm Restraints & Superstructure: Before installing arms, install arm Restraint Gears as follows: Install Restraint Gear into arm clevis, as shown in Fig. 17, so that the rounded edge (top side) of the gear teeth is facing upward. Then, install the (2) 3/8"- 16NC x 1-1/2" Lg. HHCS (8 total for all 4 arms) and 3/8" Spring Lockwashers into the gear and arm as illustrated in Fig. 17, but do not tighten.

After installing Restraint Gears, raise carriages to a convenient height. Grease swivel arm pins and holes with Lithium grease. Raise Gear Block by pulling upward on pin-ring to allow enough clearance for the Restraint Gear and arm to slide into the yoke clevis and under the teeth of the Gear Block (or gear stop), Fig. 18. Install 1-1/2" diameter arm pin(s) and 3/16" x 2" cotter pin(s), Fig. 19. After installing arm pin, torque the two Restraint Gear bolts to 30-34 ft.-lbs. Let the Gear Block down allowing the teeth of the Restraint Gear and Gear Block to mesh together, Fig. 18.

NOTE: Once arm is installed in yoke, pull up actuator pin and swing arm fully around, being sure that the Restraint Gear and Gear Block always stay aligned. If they do not stay aligned, remove restraint gear and install in the opposite position.

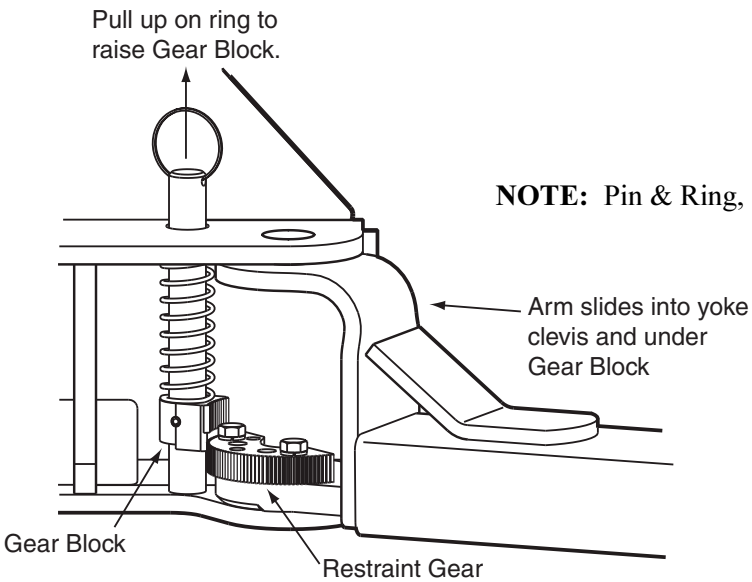
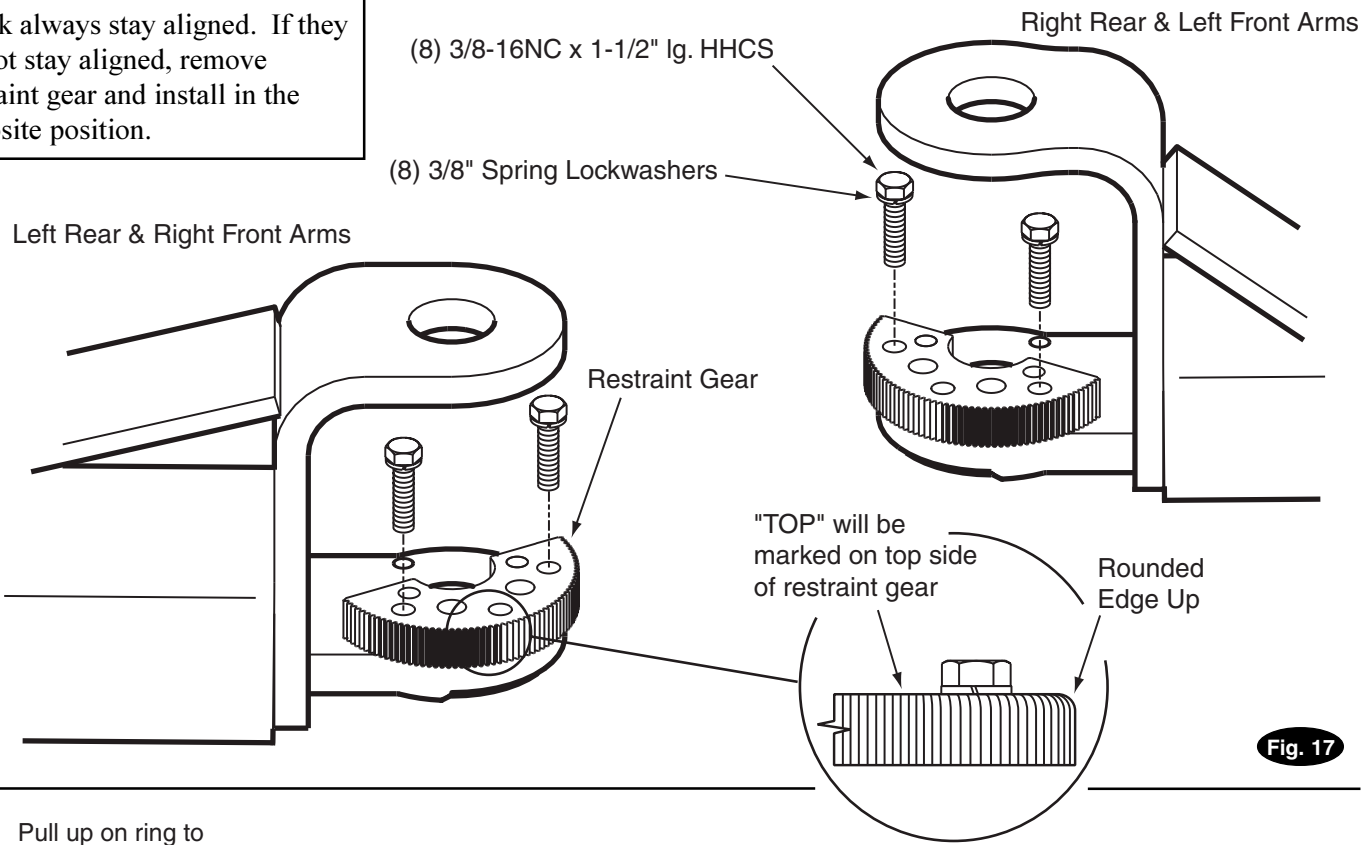

NOTE: Pin & Ring, Spring, & Gear Block are all preassembled.

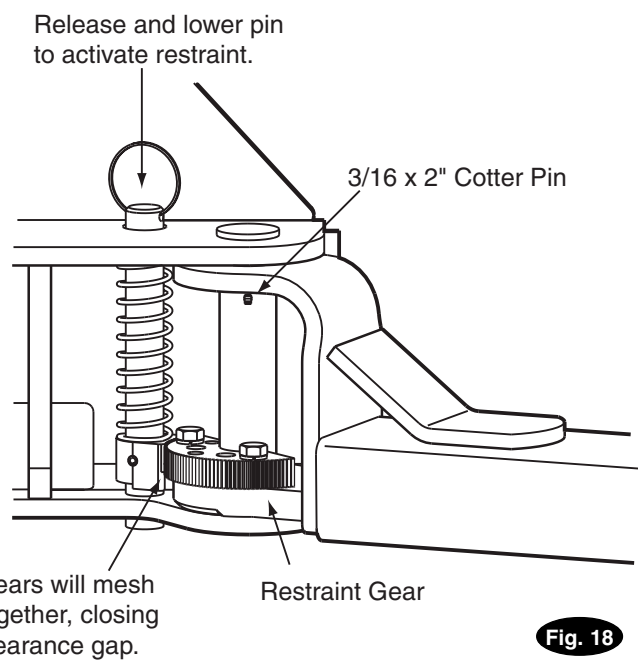

NOTE: To check operation of arm restraints, raise carriage 1" min. from full down position. Pull up on pin-ring and adjust arms to desired position. To engage restraint, let pin-ring down allowing gear teeth to mesh together. It may be necessary to rotate arm slightly to engage gear teeth.

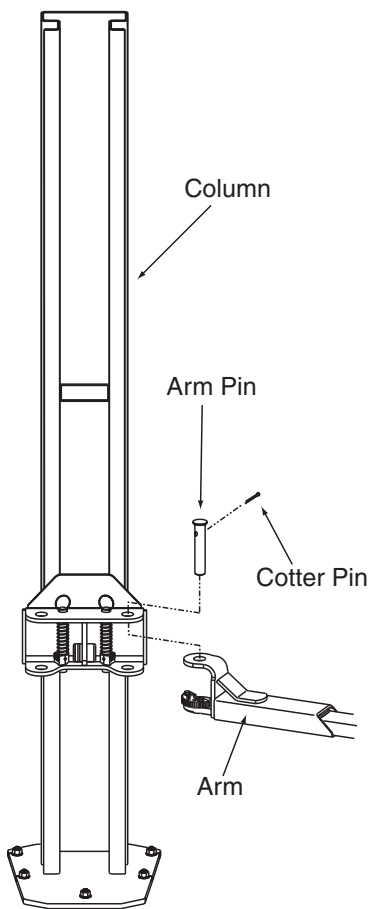

Fig. 19

18. Installation of Rack for Adapter Extensions:

Install racks as shown, Fig. 20, using 5/16"-18NC x 3/8" PHMS.

19. Door Bumper Installation:

- 1) Press long bumper on column edge, Fig. 21.
- 2) Press short bumper on top edge of carriage tube, Fig. 21.

20. Latch Cable Adjustment:

- A) Check to make sure the latch will properly engage and disengage. *Slowly* release the latch handle. A 1/8" gap between the top of the latch dog and the column is allowable.
- B) When raising, listen to latches to be sure that both latch dogs fall into latch slots. If they do not, loosen clamp and adjust tension as necessary.
- C) Install left latch cover using 5/16-18NC x 3/8" lg PHMS.

21. Pressure Test:

Run lift to full rise and keep motor running for 5 seconds. Stop and check all hose connections. Tighten or reseal if required. Repeat air bleeding of cylinders.

22. Equalizer Cable Adjustments:

Raise lift to check equalizer cable tension. Below carriage, grasp adjacent cables between thumb and forefinger, with about 15 lbs. effort you should just pull the cables together. Adjust at upper tie-offs Fig. 10b.

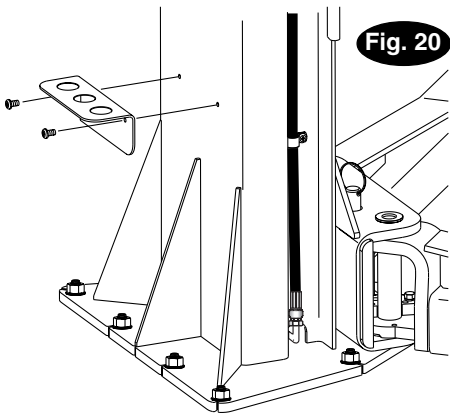

Fig. 20

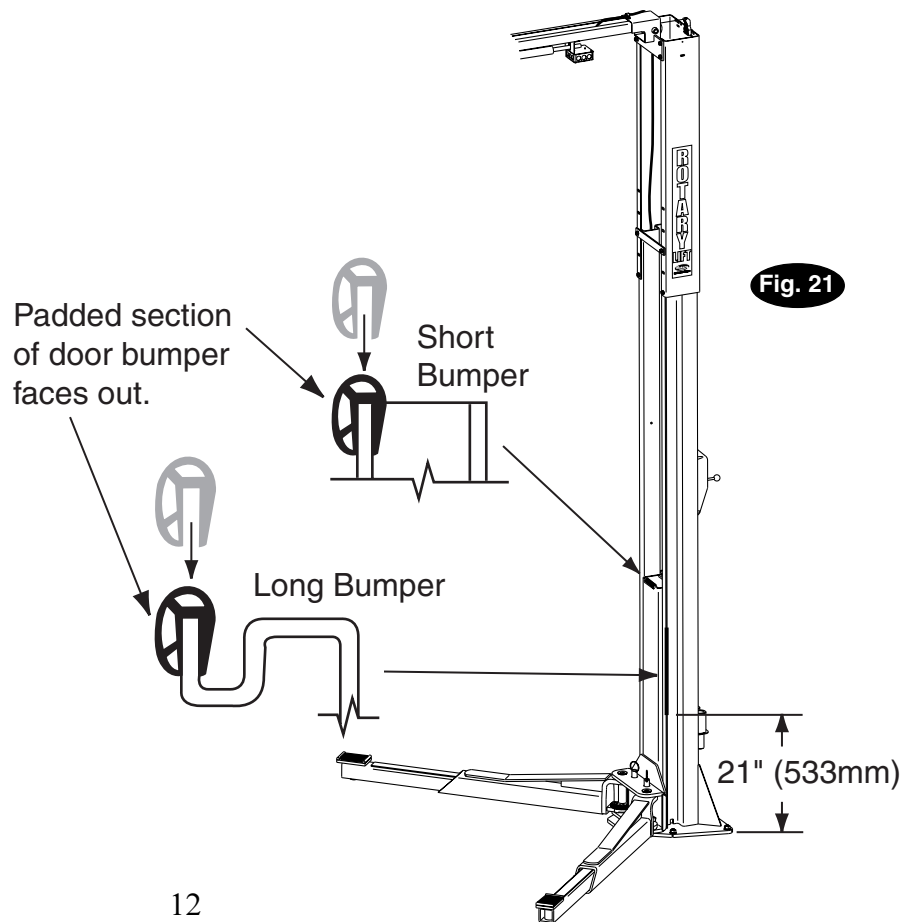

Fig. 21

23. Latch Release Decal: If latch release decal (NP266) is not already installed, then install on cover above latch release handle, Fig. 22.

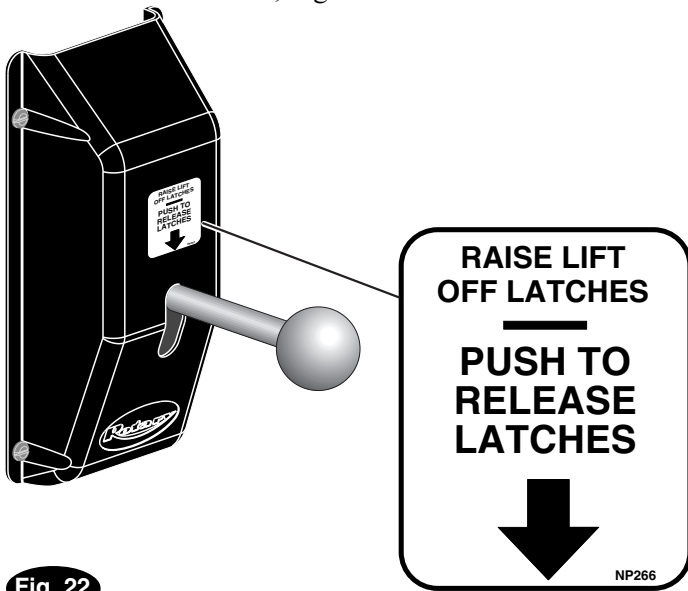
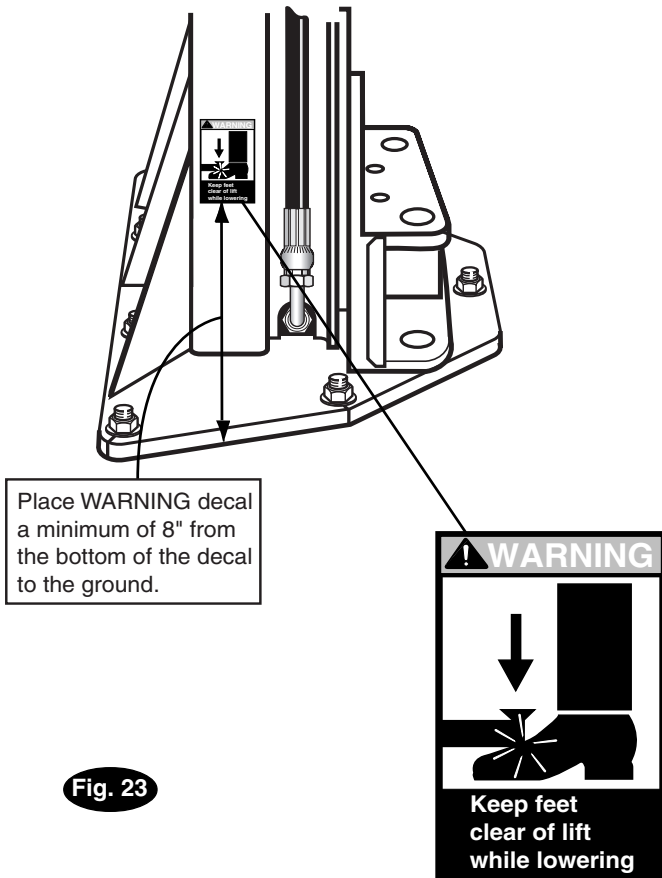

Fig. 22

24. Pinch Point Decal Location: Install enclosed pinch point decals. Place (1) decal on each column, Fig. 23.



Place WARNING decal a minimum of 8" from the bottom of the decal to the ground.

Fig. 23

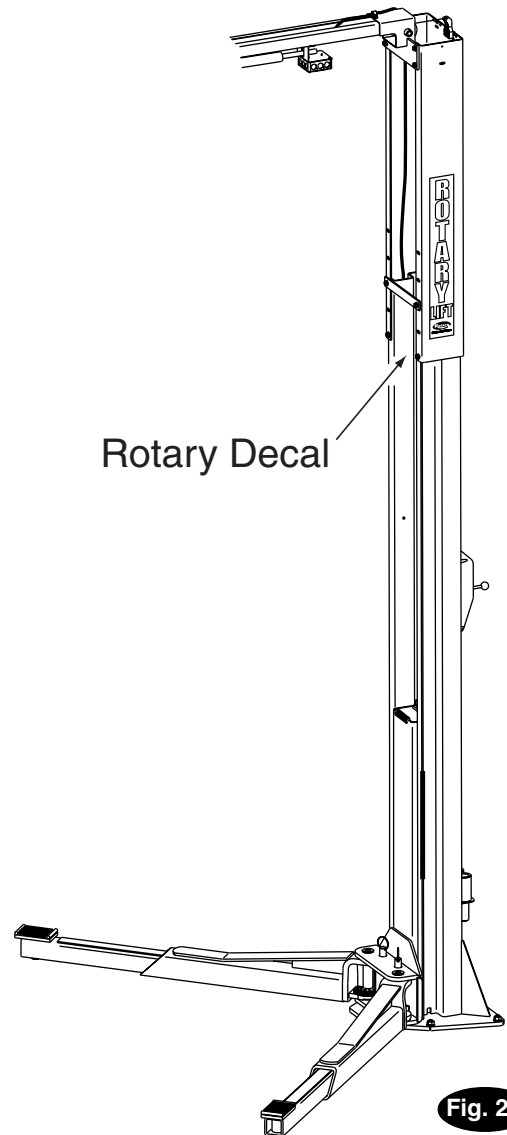

Fig. 24

25. Rotary Decal Location: Clean area where decals are to be placed. Remove backing from decals. Position and apply on approach sides of each column extension as indicated, Fig. 24, and press flat.

This page intentionally left blank.

This page intentionally left blank.

Installer: Please return this booklet to literature package, and give to lift owner/operator.

Thank You

Trained Operators and Regular Maintenance Ensures Satisfactory Performance of Your Rotary Lift.

Contact Your Nearest Authorized Rotary Parts Distributor for Genuine Rotary Replacement Parts. See Literature Package for Parts Breakdown.

Revision	Change(s) Made
D	Rotary Power Unit Longer Overhead Switch Bar
E	Changed back to Fenner Power Unit Instructions
F	Added Fenner and Rotary Power Unit Instructions
G	Added dual 3 Phase wiring color legends
H	Change 1Ø Motor Ground Location Updated 3Ø Wiring Diagram Changed 3Ø Fuse Size



World Headquarters:
ROTARY LIFT
A DOVER INDUSTRIES COMPANY
2700 Lanier Drive
Madison, IN 47250-1753 USA
Phone toll-free: 1-800-445-5438
Phone: (812) 273-1622
Fax toll-free: 1-800-822-6502
Fax: (812) 273-6502
E-mail: userlink@rotarylif.com
Web site: www.rotarylif.com

For Canada:
DOVER CORP. CANADA, LTD.
ROTARY LIFT DIVISION
130 Bridgeland Avenue Unit 210
Toronto, Ontario M6A 1Z4
Phone: (416) 256-4100
Fax: (416) 256-3924

For United Kingdom & Republic of Ireland:
ROTARY LIFT (UK) LIMITED
Madison House
2 Park Road
Dartford, Kent
DA1 1SL
Phone: +44 (0) 1322 223323
Fax: +44 (0) 1322 222454

For Europe:
ROTARY LIFT EUROPE
Berlinger Ring 163 B
D-64625 Bensheim
Phone: +49 (0) 6251 787037
Fax: +49 (0) 6251 787038



World Leader in Lift Systems