

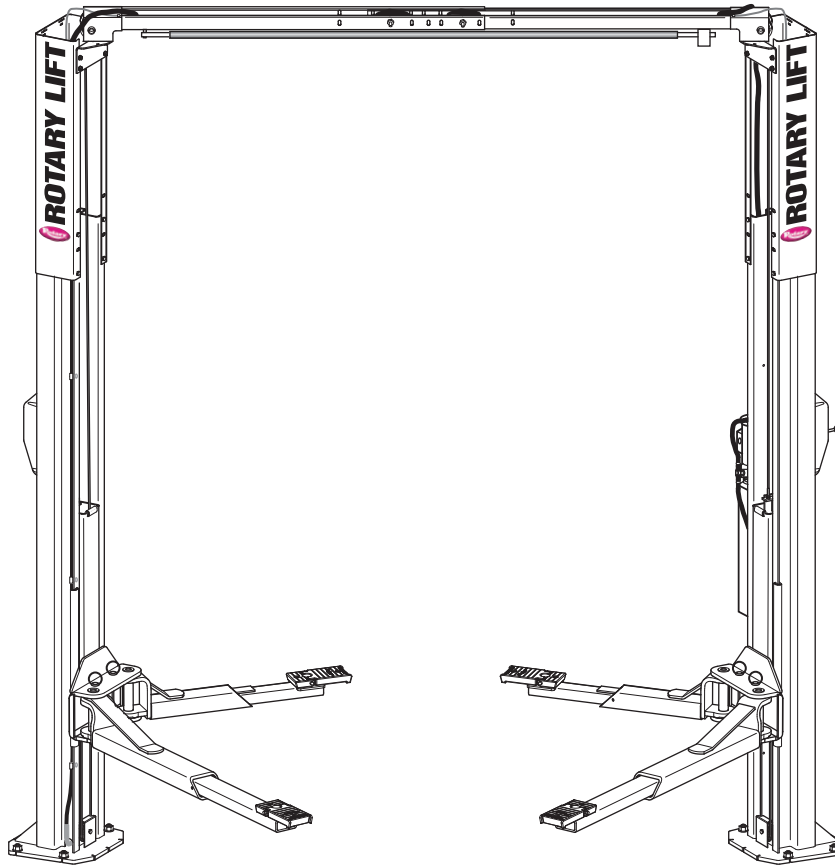

SPOA10, SP010, SPOA7 Hybrid, & Shockwave™ Models

(500, 700, And 800 Series Lifts)
Capacity 10,000 lbs.



P
A
R
T
S

B
R
E
A
K
D
O
W
N

IMPORTANT: When ordering parts or requesting service always give exact model and power unit serial number. Model number is shown on nameplate attached to power unit column. Power unit serial number is located on side of power unit.

OWNERS RECORD
Complete information at right and keep in a safe place.

Date Installed _____
 Installed in Bay # _____
 Power Unit Serial # _____
 Power Unit Model # _____
 Lift Serial # _____
 Lift Model # _____

NOTE: For replacement parts -See your nearest Rotary Parts Distributor.

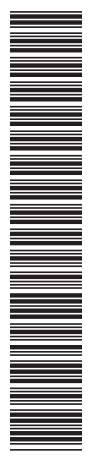

PB2-2-44
Rev. AB 5/13/2015

1. L.H. Column Standard Weldment	N752
L.H. Column Seismic Weldment	N766
2. R.H. Column Standard Weldment.....	N755
R.H. Column Seismic Weldment.....	N768
3. Column Extension	
Standard Height	N470
EH-1 MODEL	N471
EH-2 MODEL	N472
EH-4 MODEL (SPO10 only).....	N474
4. Carriage Yoke Weldment	N822
5. Arm Pin	N2154
6. 1/4"-20NC x 3/4" Lg. HHCS	40099
7. Hydraulic Cylinder	
68" Rise	N3156
71" Rise	N382
8. Power Unit	
1Ø 60Hz	**P1302/P3302
1Ø 50Hz	**P1389/P3389
3Ø	**P1347/P3347
3Ø 575V	**P1359/P3359
3Ø 380V (S Model).....	**P1510/P3510
9. Power Unit Hose	FJ837
10. 5/16"-18NC x 1-1/2" Flanged HHCS (Full Thread)	40509
11. NA.....	NA
12. 5/16"-18NC Hex Flanged Lock Nut.....	40678
13. Actuator Pin Handle	FJ7985-1
14. Actuator Pin.....	N121-1
15. Retaining Pin.....	N119-3
16. Arm Restraint Spring.....	FJ7656-2
17. Bleeder Screw (Specify Manufacturer)	N/A
18. Carriage Bumper.....	FA941
19. Arm Restraint Pawl.....	N2121
20. Approach bumper	FJ7391-1
21. 5/8"-11NC Nylon Insert Lock Nut.....	40743
22. Truarc #5304-75 Klipring for 3/4" Shaft.....	41411
23. Sheave	N377
24. 1/4"-20NC Zinc Hex Nut.....	40627
25. Sheave Cover	N119-1
26. 1/4"-20NC x 3/8" Lg. PHMS Plated (2 pcs.).....	40063
27. Slider block	FJ7360
28. 3/4" Concrete Anchor	FJ7380
29. 1-1/2" O.D. x .760-.770" I.D. x .045" Bushing.....	41388
30. 1/4"-20NC x 2-3/4" HHCS.....	40114
31. 1/4"-20NC Insert Locknut	40642
32. 1/8" x 1" Lg. Cotter Pin (3Ø only)	41200
33. Switch Bar Assembly	
1Ø SPOA10NB	N415
1Ø SPOA10/SP010 / 3Ø w/ Push Button.....	N467
3Ø.....	N434
34. Wheel Spotting Dish Kit.....	FF729
35. 1/4" Flat Washer	40795
36. 3/8"-16 NC x 3/4" Long Flanged HHCS	40124
*37. Arm Restraint Kit (1 arm)	*N2148
38. Overhead Hose	
Standard.....	N3103
EH-1 MODEL	FJ842
EH-2 MODEL	FJ843
EH-4 MODEL (SPO10 only).....	FJ845

39. Equalizer Cables	
SPOA10NB	N384
SPOA10NB EH-1 MODEL.....	N385
SPOA10NB EH-2 MODEL.....	N386
SPOA10.....	N372
SPOA10 EH-1 MODEL.....	N378
SPOA10 EH-2 MODEL.....	N373
SP010.....	N374
SP010 EH-1 MODEL.....	N379
SP010 EH-2 MODEL.....	N375
SP010 EH-4 MODEL.....	N376
40. Capacitor Box.....	FA7147-1
Capacitor Box Cover Plate	FA7366-1
Drum Switch	FA7364
Drum Switch Lever	FA7364-1
M5 x 45 PHMS, Plated.....	41672
41. Locking Latch Cable	FJ7600
42. Cable Guide.....	N618
43. 3/8"-16NC Flanged Locknut.....	40664
44. Sheave Shaft	FJ7444-8
45. Actuator Assembly (3Ø).....	N432-5
46. Cable End Bracket.....	N619
47. Hose Clip	N383
48. L.H. Overhead Assembly (Outer)	N480
49. R.H. Overhead Assembly (Inner)	N481
50. Branch Tee.....	FJ7668
51. Column Mounting Bracket	N439
52. 3/8"-16NC x 3/4" Carriage Bolts	N/A
53. 1/4"-20NC Flanged Locknut.....	40641
54. 3/4" Spacer	FJ7871
55. Cutoff Switch Assembly	
1Ø / 3Ø w/ Push Button	N413
3Ø.....	N432
Cutoff Switch	
1Ø / 3Ø w/ Push Button	N413-1
3Ø.....	N432-1
56. 1/4" External Tooth Lockwasher.....	40779
57. 1/4"-20NC x 1" HHCS Grade 5.....	40108
58. Spring Pin-1/4" dia. x 1-1/2" Lg. (Stainless)	14427
59. Shim	FJ716-6
60. Front Shim	FJ7659-3

*Arm Restraint Kit (1 Arm) Includes items 13, 14, 15, 16, 19 & 58. Also includes Restraint Gears and attaching hardware (items 21, 22 & 23) from Arm Detail section.

**Two different power units were used. Please verify your model number before ordering parts.

Note: Standard hardware items should be purchased from local hardware source when possible.

CAUTION

Care should be taken to use hardware equal to that specified in this listing. (If grade is not specified, use Grade 2 minimum.)

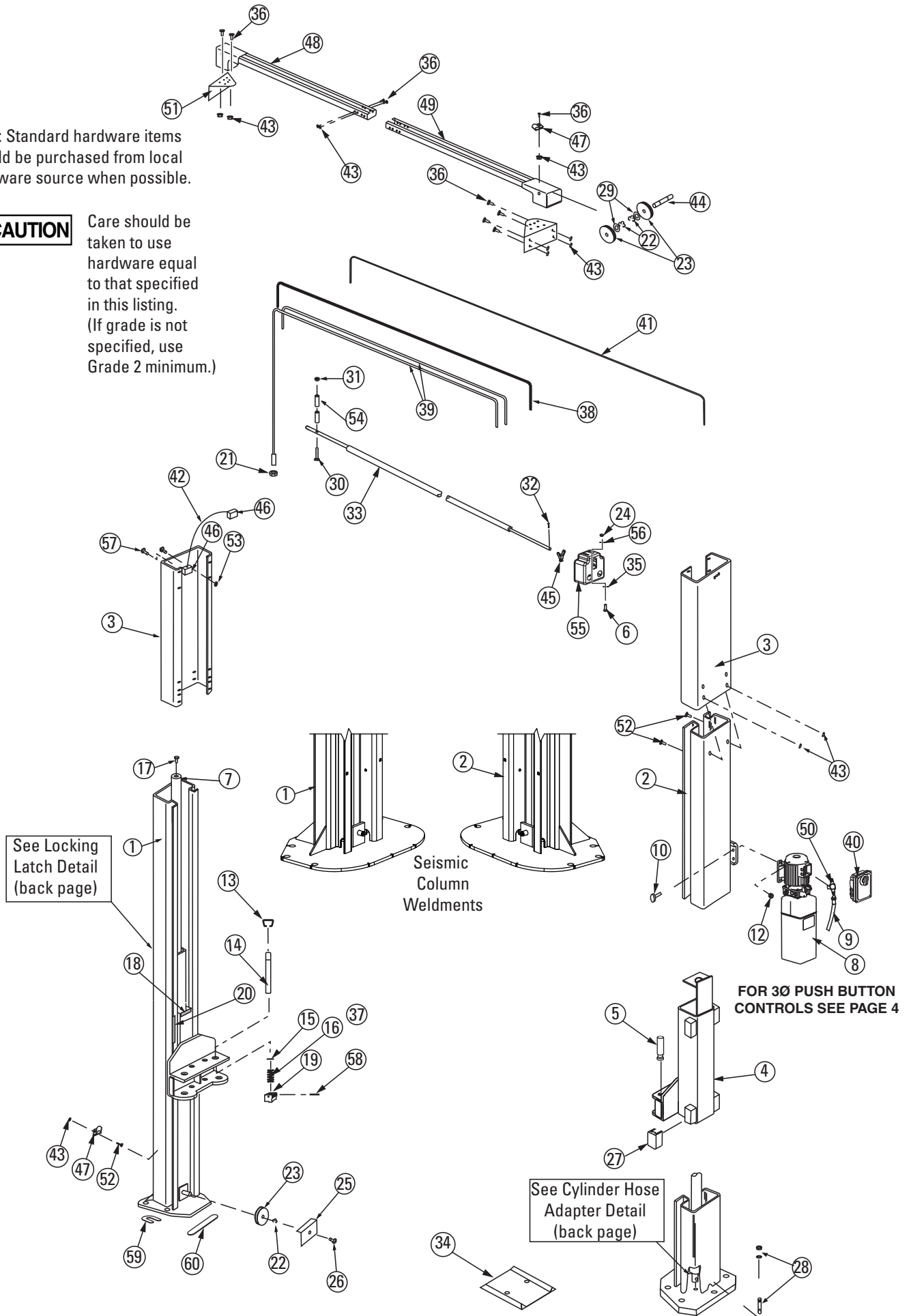

3Ø POWER UNIT

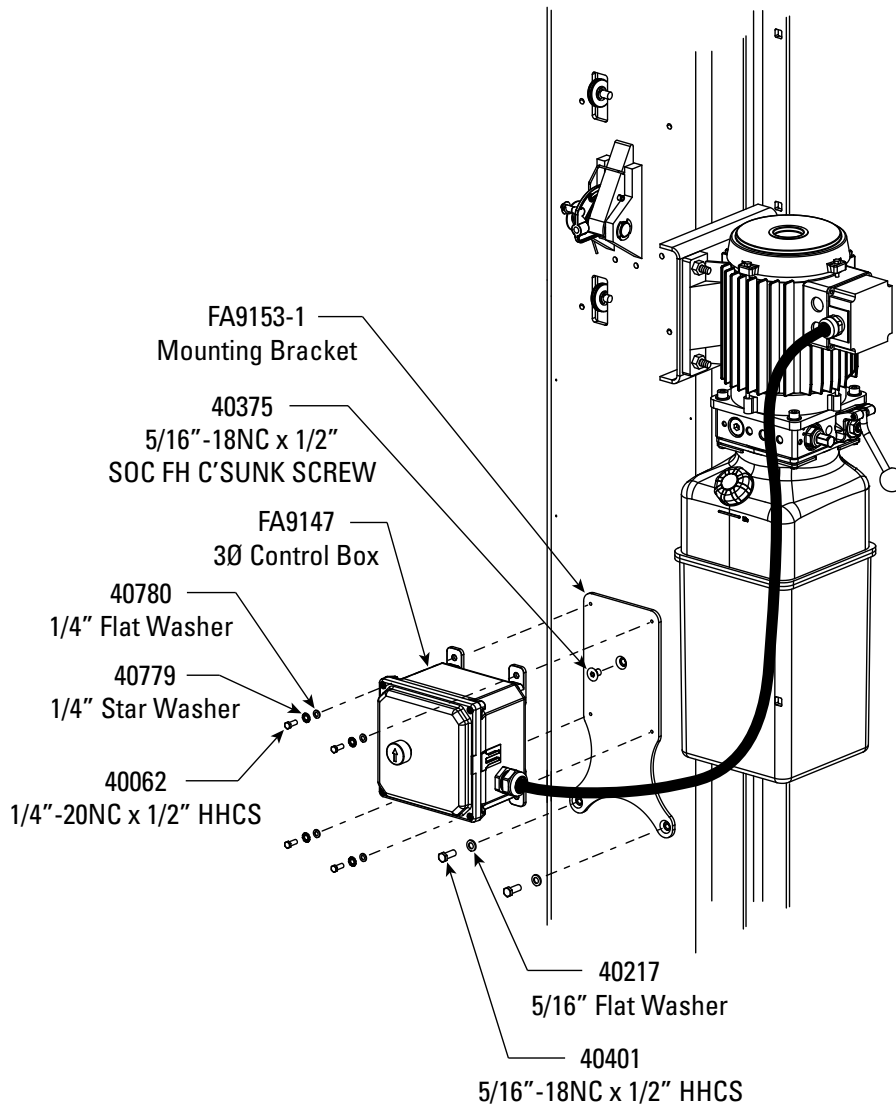

FA9147 Includes Items:	
FA9147-1	3Ø Control Box Enclosure with Gasket
FA9147-2	25 AMP Contactor, 3 Pole with 480 Volt Coil GE CR553AB3CAA
FA9147-6	Contactor Coil DB1AB 208-240 Volt for Contactor GE CR553A
FA9147-8	Switch Momentary Push Button with Contact Block
FA9147-9	Cord 600 Volt 4-Wire 42" Long with Ring Terminals

FA9147-12	550-600 Volt Coil GE Pin PB1AD for 575 Volt Lifts Only
-----------	--

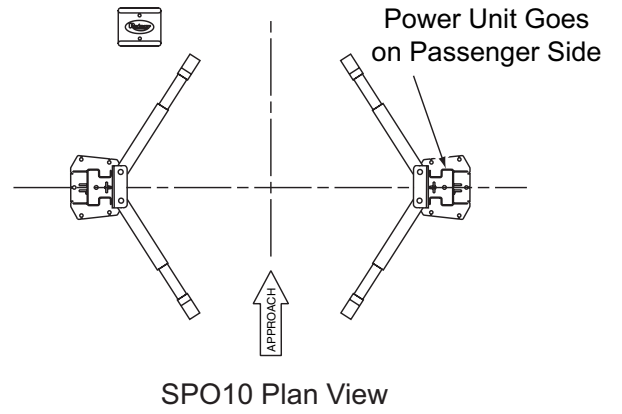
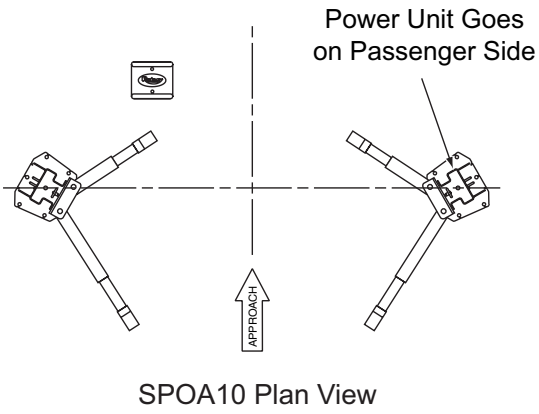

***Notes: 5TX, 5GX or 5BX Series?**

To find out if you have a **5TX, 5GX or 5BX** series arms look at the **last (3) numbers on the end** of your lift model number.

EXAMPLE: SPOA10N**5G5** would be a **5GX Series** model.



Model number can be found on a tag on the side of the lift. The "X" is a variable number used to fill the place of the actual last number on your lift model number tag.

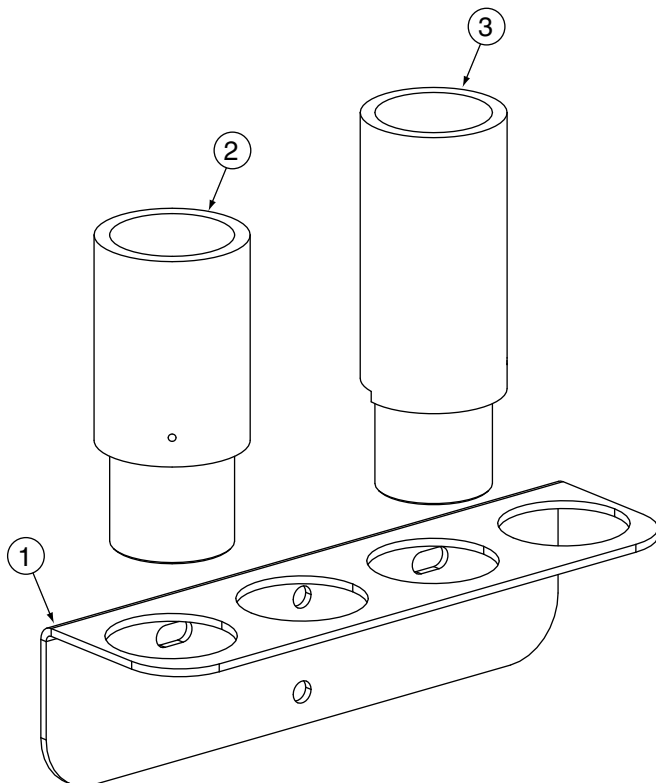

1.	Adapter Rack	FJ6127
2.	3-1/2" (90mm) Adapter Extension	FJ6171-1
3.	5-1/4" (130mm) Adapter Extension	FJ6171-2

Arm Detail

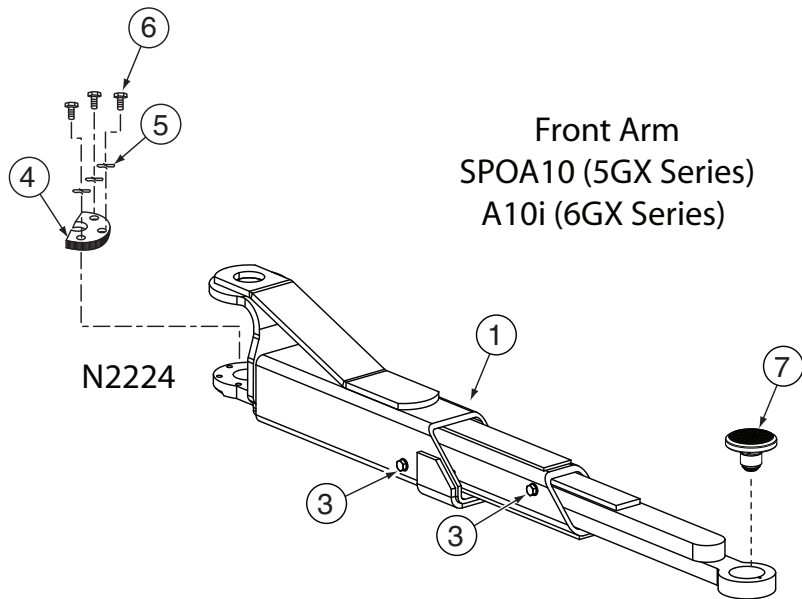

Front Arm
SPOA10 (5GX Series)
A10i (6GX Series)

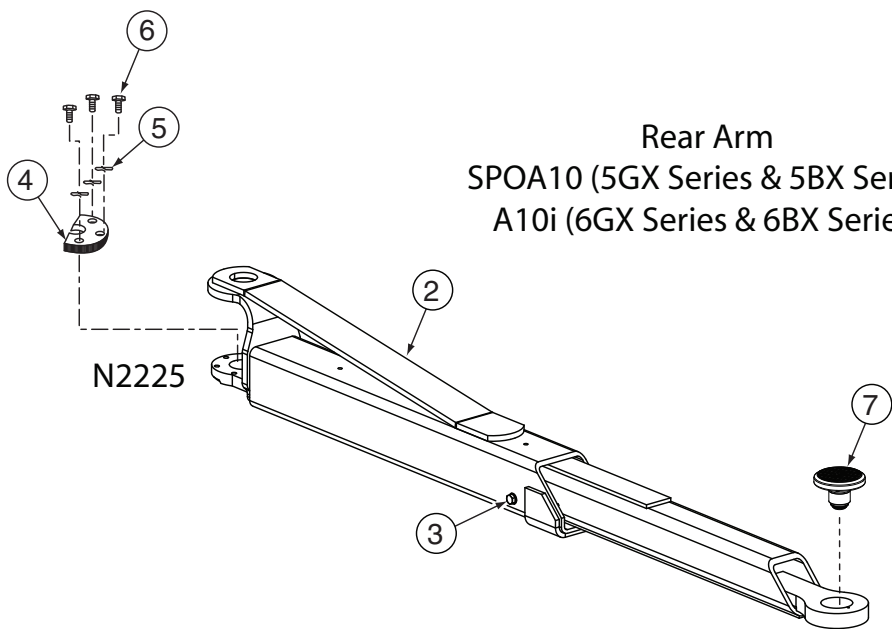

Rear Arm
SPOA10 (5GX Series & 5BX Series)
A10i (6GX Series & 6BX Series)

1.	Front Arm	
	SPOA10 (5GX Series)	*N2224
2.	Rear Arm	
	SPOA10 (5GX Series) & (5BX Series)	*N2225
3.	Stop Bolt Assembly	N219

4.	Arm Restraint Gear	N2122
5.	3/8" Spring Washers (For Lifts With Tapped Bearing Bar)	40818
6.	3/8"-16NC x 1-1/2" HHCS Grade 5	40201
7.	Low Profile Adapter Assembly	FJ6202
	Rubber Pad	FJ6202-3

Arm Detail

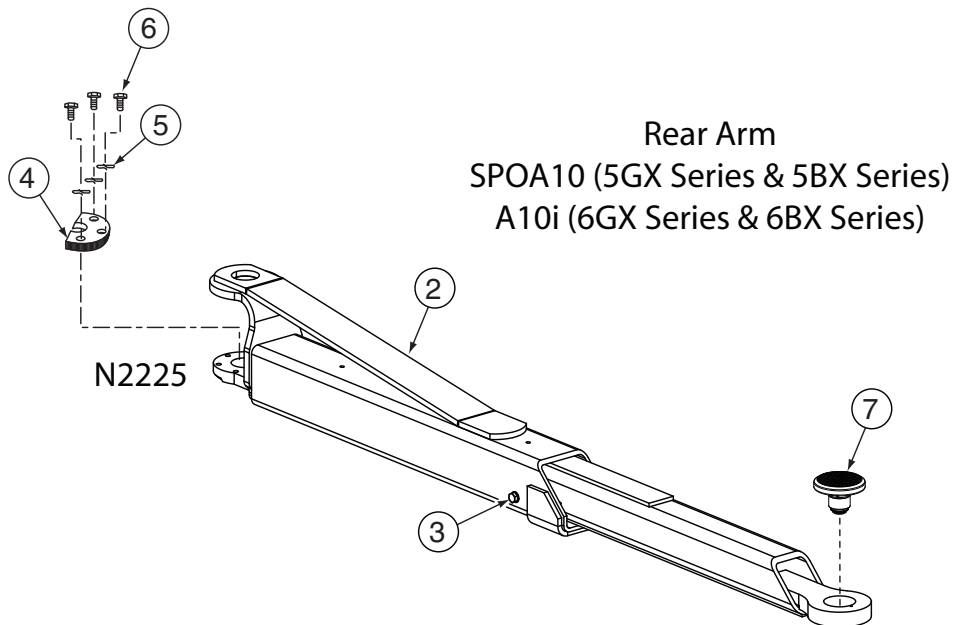
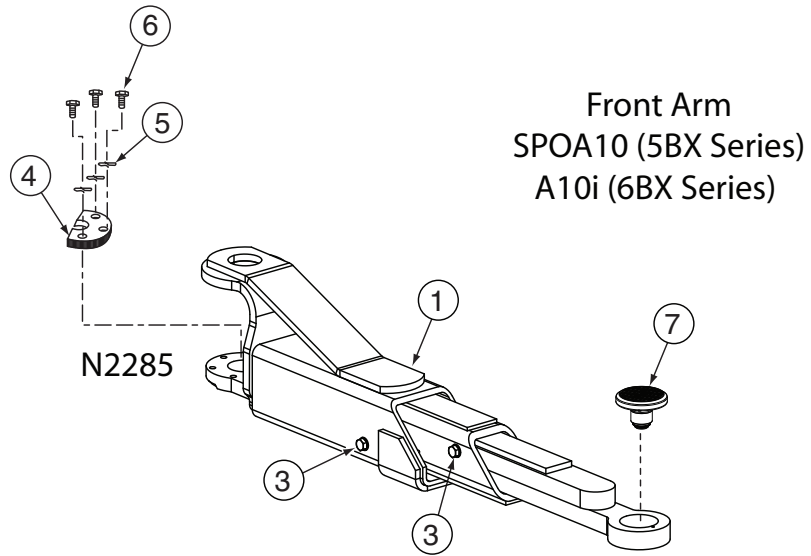

1.	Front Arm	
	SPOA10 (5BX Series)	*N2285
2.	Rear Arm	
	SPOA10 (5GX Series) & (5BX Series)	*N2225
3.	Stop Bolt Assembly	N219
4.	Arm Restraint Gear	N2122

5.	3/8" Spring Washers (For Lifts With Tapped Bearing Bar)	40818
6.	3/8"-16NC x 1-1/2" HHCS Grade 5	40201
7.	Low Profile Adapter Assembly	FJ6202
	Rubber Pad	FJ6202-3

Arm Detail

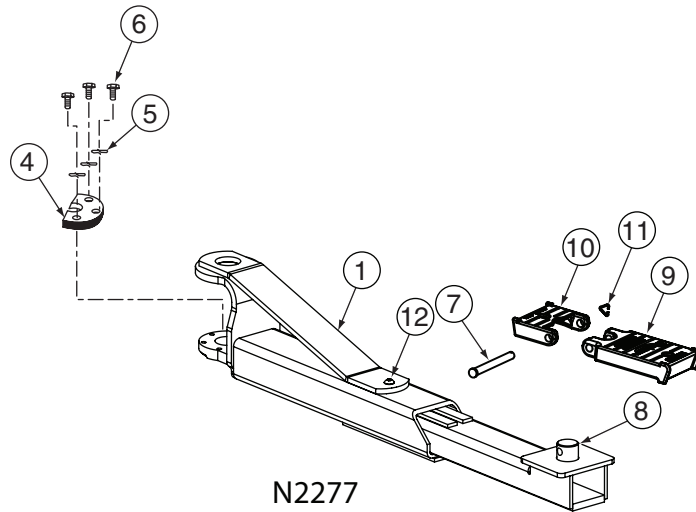

N2277

Front Arm
SPOA10 (70X Series)
A10i (70X Series)

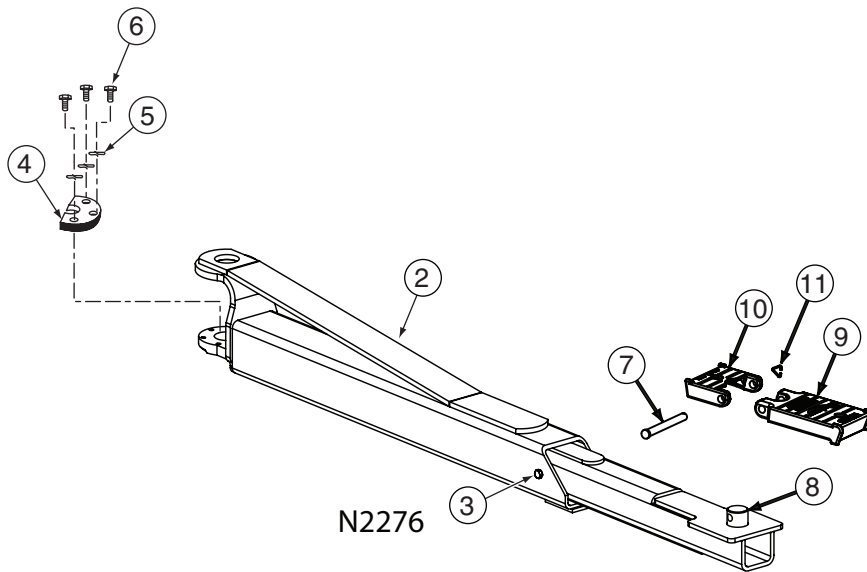

N2276

Rear Arm
SPOA10 (70X Series)
A10i (70X Series)

1.	Front Arm	
	SPOA10 (70X Series)	*N2277
2.	Rear Arm	
	SPOA10 (70X Series)	*N2276
3.	Stop Bolt 3/8"-16NC x 1/2" Lg. HHCS	40126
4.	Arm Restraint Gear	N2122
5.	3/8" Spring Washers (For Lifts With Tapped Bearing Bar)	40818

6.	3/8"-16NC x 1-1/2" HHCS Grade 5	40201
7.	Adapter Pin	FJ6179
8.	Adapter Swivel Pin	FJ79-6
9.	High Step Adapter	FJ6177
10.	Low Step Adapter	FJ6178
11.	3/32" Hog Ring for 1/2" Shaft (8 required)	FJ671-6
12.	Front Stop Bolt (M10 x 1.5 x 20mm BHCS)	41650

Arm Detail

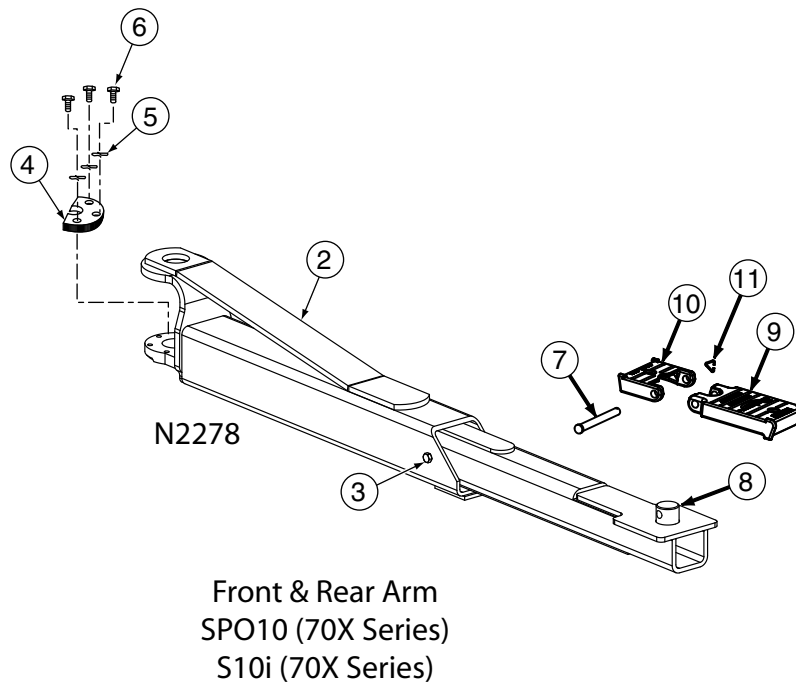
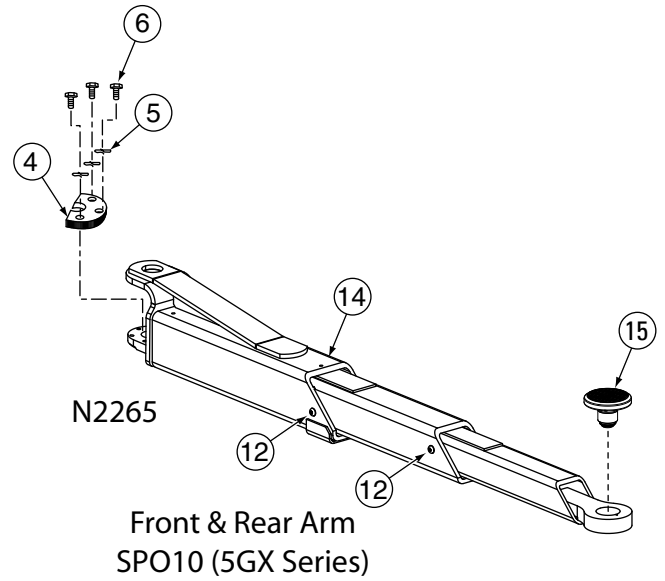
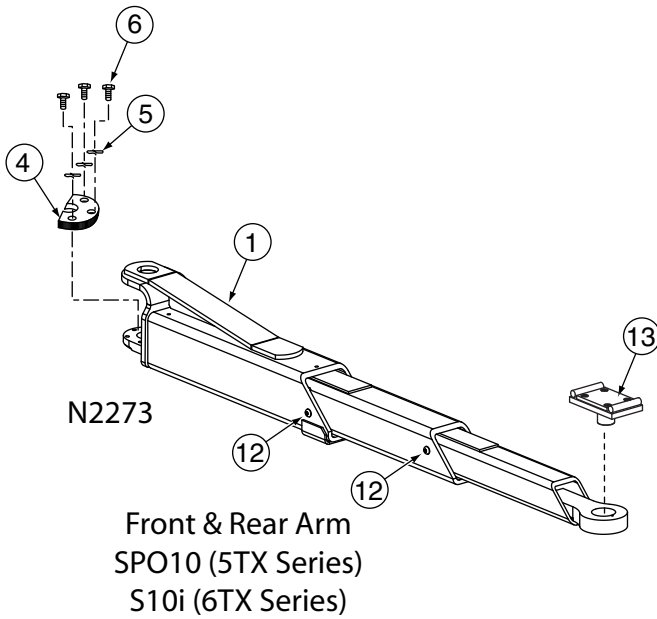

1.	Front And Rear Arm SPO10 (5TX Series)	*N2273
2.	Rear Arm SPO10 (70X Series)	*N2278
3.	Stop Bolt 3/8"-16NC x 1/2" Lg. HHCS	40126
4.	Arm Restraint Gear	N2122
5.	3/8" Spring Washers (For Lifts With Tapped Bearing Bar)	40818
6.	3/8"-16NC x 1-1/2" HHCS Grade 5	40201
7.	Adapter Pin	FJ6179

8.	Adapter Swivel Pin	FJ79-6
9.	High Step Adapter	FJ6177
10.	Low Step Adapter	FJ6178
11.	3/32" Hog Ring for 1/2" Shaft (8 required)	FJ671-6
12.	Front Stop Bolt (M10 x 1.5 x 20mm BHCS)	N2264-15
13.	Adapter Assembly (SPO10) 3-Stage Arm Rubber Pad	FJ6214 FJ6158-4
14.	Front and Rear Arm SPO10 (5GX Series)	*N2265
15.	Low Profile Adapter Assembly Rubber Pad	FJ6202 FJ6202-3

Arm Detail

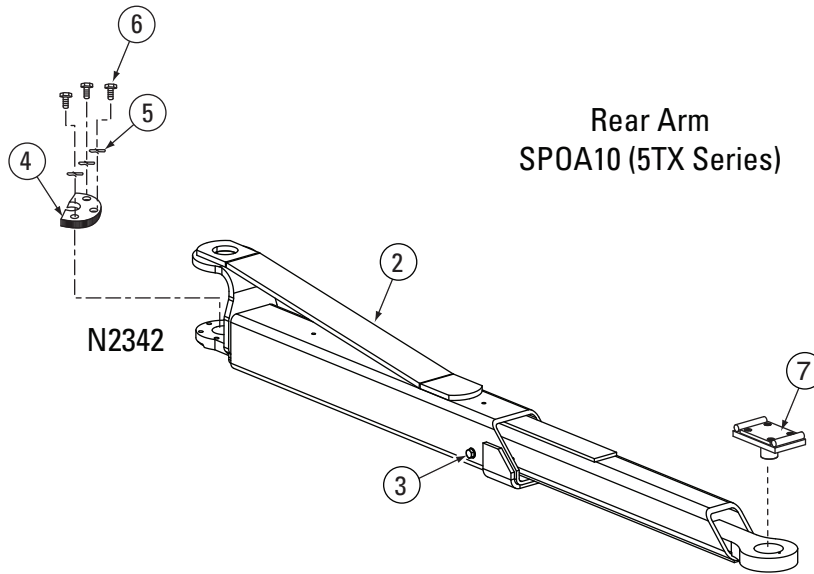
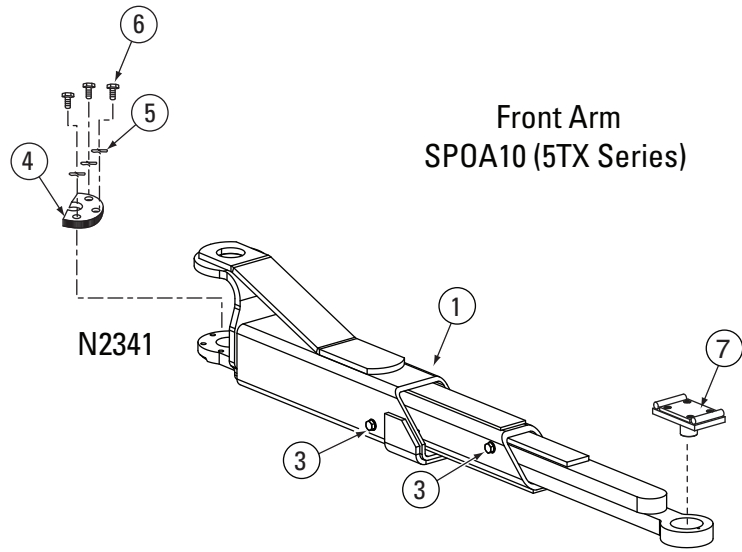

1.	Front Arm	
	SPOA10 (5TX Series)	*N2341
2.	Rear Arm	
	SPOA10 (5TX Series)	*N2342
3.	Stop Bolt Assembly	N219
4.	Arm Restraint Gear	N2122

5.	3/8" Spring Washers (For Lifts With Tapped Bearing Bar)	40818
	3/8"-16NC x 1-1/2" HHCS Grade 5	40201
7	Adapter Assembly 3-Stage Arm	FJ6214
	Rubber Pad	FJ6158-4

Arm Detail SPOA7 Low Profile Arm

1.	Front Arm	
	SPOA10 (5TX Series)	*N2295
2.	Rear Arm	
	SPOA10 (5TX Series)	*N2294
3.	Stop Bolt Assembly	N219
4.	Arm Restraint Gear	N2122

5.	3/8" Spring Washers (For Lifts With Tapped Bearing Bar)	40818
6.	3/8"-16NC x 1-1/2" HHCS Grade 5	40201
7.	Adapter Assembly 3-Stage Arm	FJ6202
	Rubber Pad	FJ6202-3

Front Arm
SPOA7 (5LX Series)

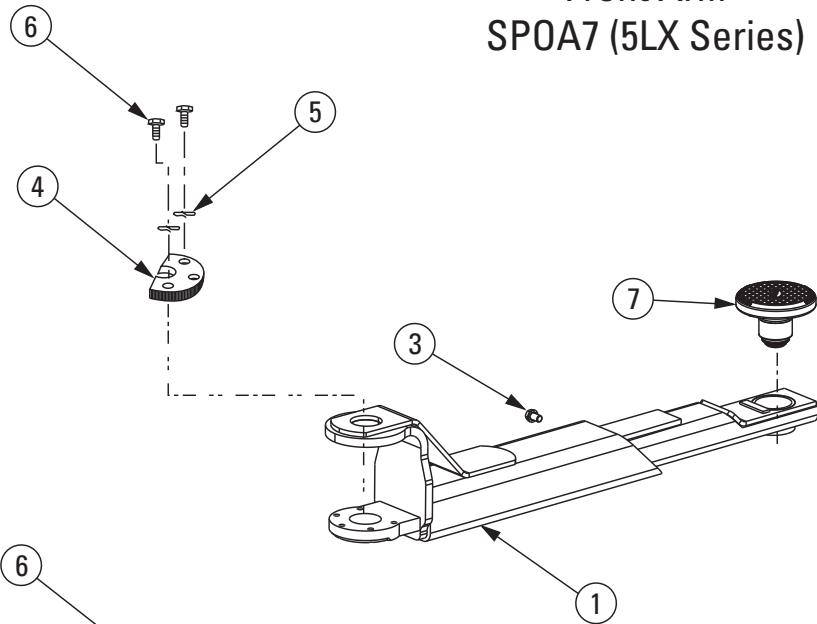

Rear Arm
SPOA7 (5LX Series)

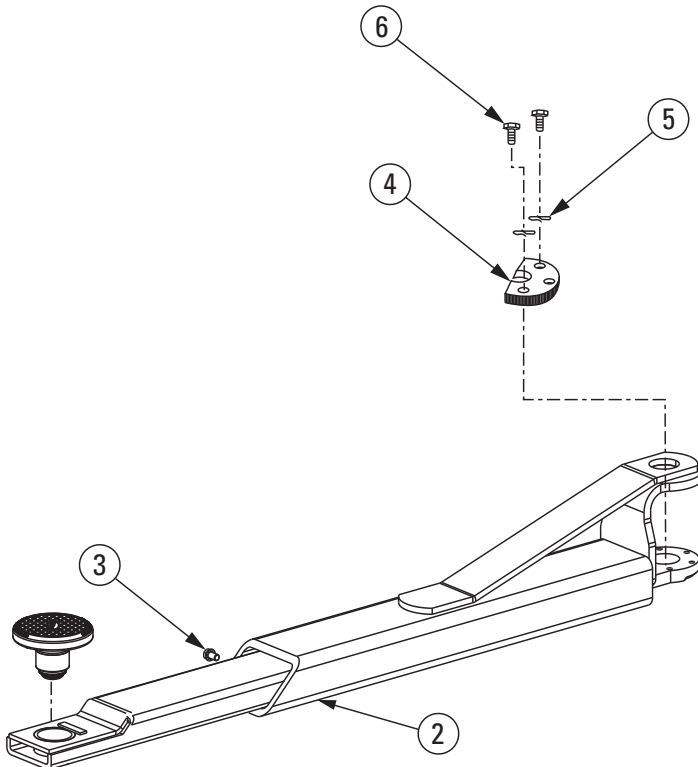

Arm Detail SPOA7 Hybrid

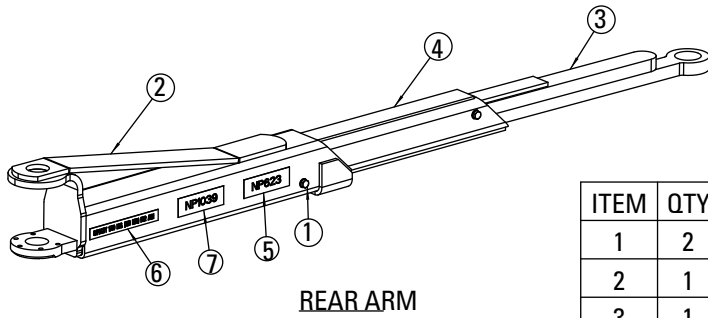

REAR ARM

ITEM	QTY	PART NO.	DESCRIPTION
1	2	N219	STOP BOLT ASSEMBLY
2	1	N2336-1	7K 3-STAGE OUTER ARM WELDMENT
3	1	N2336-2	7K 3-STAGE INNER ARM WELDMENT
4	1	N2336-3	7K 3-STAGE MIDDLE ARM WELDMENT
5	2	NP623	ALWAYS USE ADAPTERS NAMEPLATE
6	2	NP874	CAPACITY NAMEPLATE
7	2	NP1039	USE TRUCK ADAPTERS NAMEPLATE

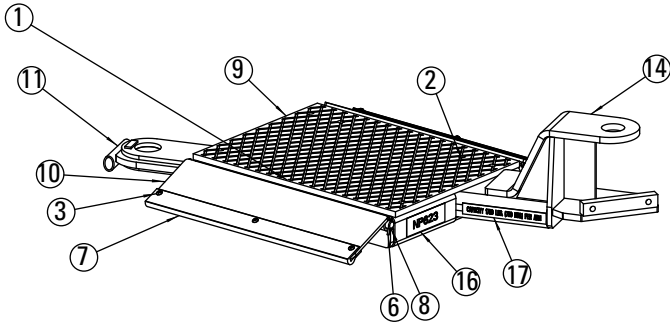

LEFT HAND PAD

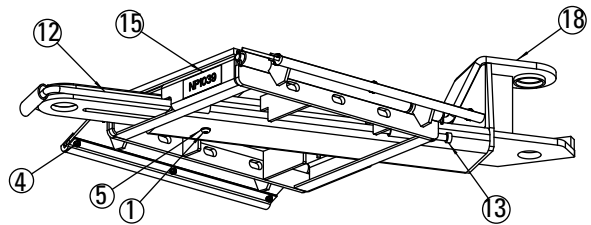

RIGHT HAND PAD

ITEM	QTY	PART NO.	DESCRIPTION
1	1	40157	3/8"-16NC x 3/4" Lg HEX SOC BHCS, GRD2
2	4	40174	1/4 x .475 BLIND RIVET McMASTER-CARR #97517A651 or EQ.
3	6	40192	#10-24NC x 3/4 Lg. PHILLIPS TRUSS HEAD SCREW, PLATED
4	6	40633	#10-24NC HEX FLGD WZLOCK NUT, PLTD
5	1	40843	3/8" INT TOOTH LW, PLTD
6	4	41202	5/32" x 1" Lg COTTER PIN
7	2	FC134-33	RAMP CHOCK SLIDE
8	2	FC5179-5	PIN
9	1	FJ2494	FRONT PAD RUBBER PAD
10	2	N2249	2-POST PAD LIFT RAMP WELDMENT
11	1	N2338-6	FRONT PAD INNER ARM WELDMENT
12	1	N2338-13	FRONT PAD INNER ARM ACTUATOR BAR
13	1	N2338-16	INNER ARM ACTUATOR ROD THUMB SCREW
14	1	N2339-1	LEFT HAND FRONT PAD WELDMENT
15	1	NP1039	USE TRUCK ADAPTER NAMEPLATE
16	1	NP623	RUBBER PAD ADAPTER NAMEPLATE
17	1	NP874	CAPACITY 1750 LBS NAMEPLATE
18	1	N2338	RIGHT HAND FRONT PAD WELDMENT

800 Series Arms Detail

N2393
A10 REAR

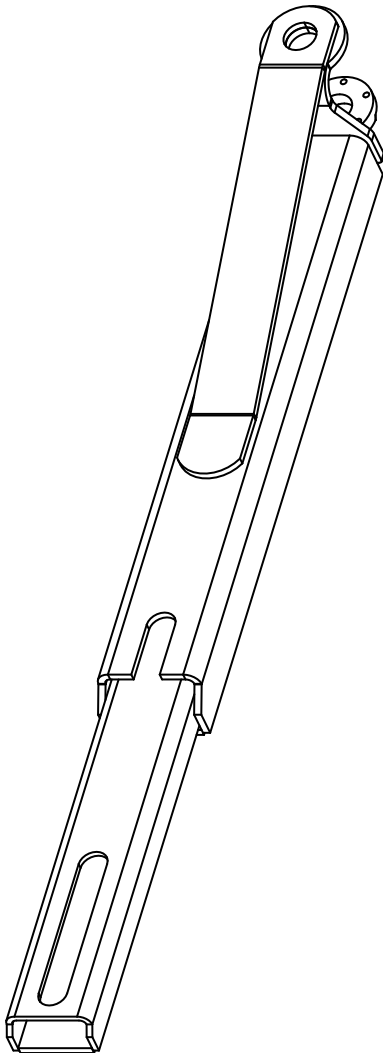

N2394
A10 FRONT

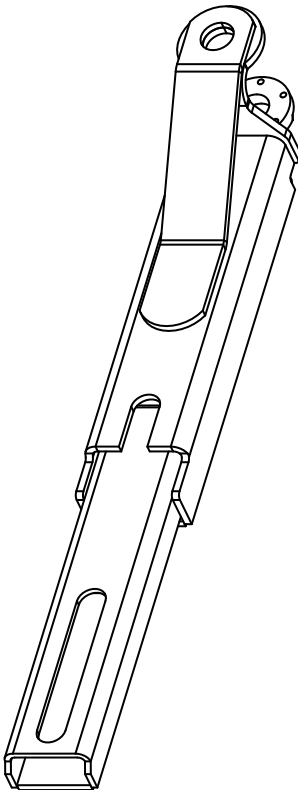

N2395
O10

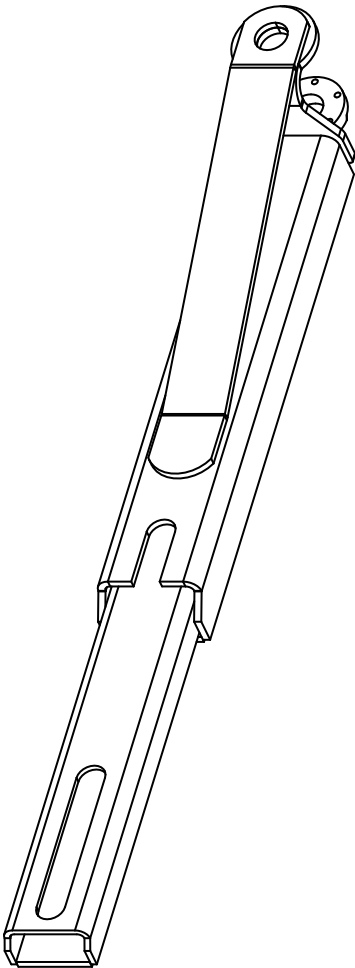

800 Series Options Detail

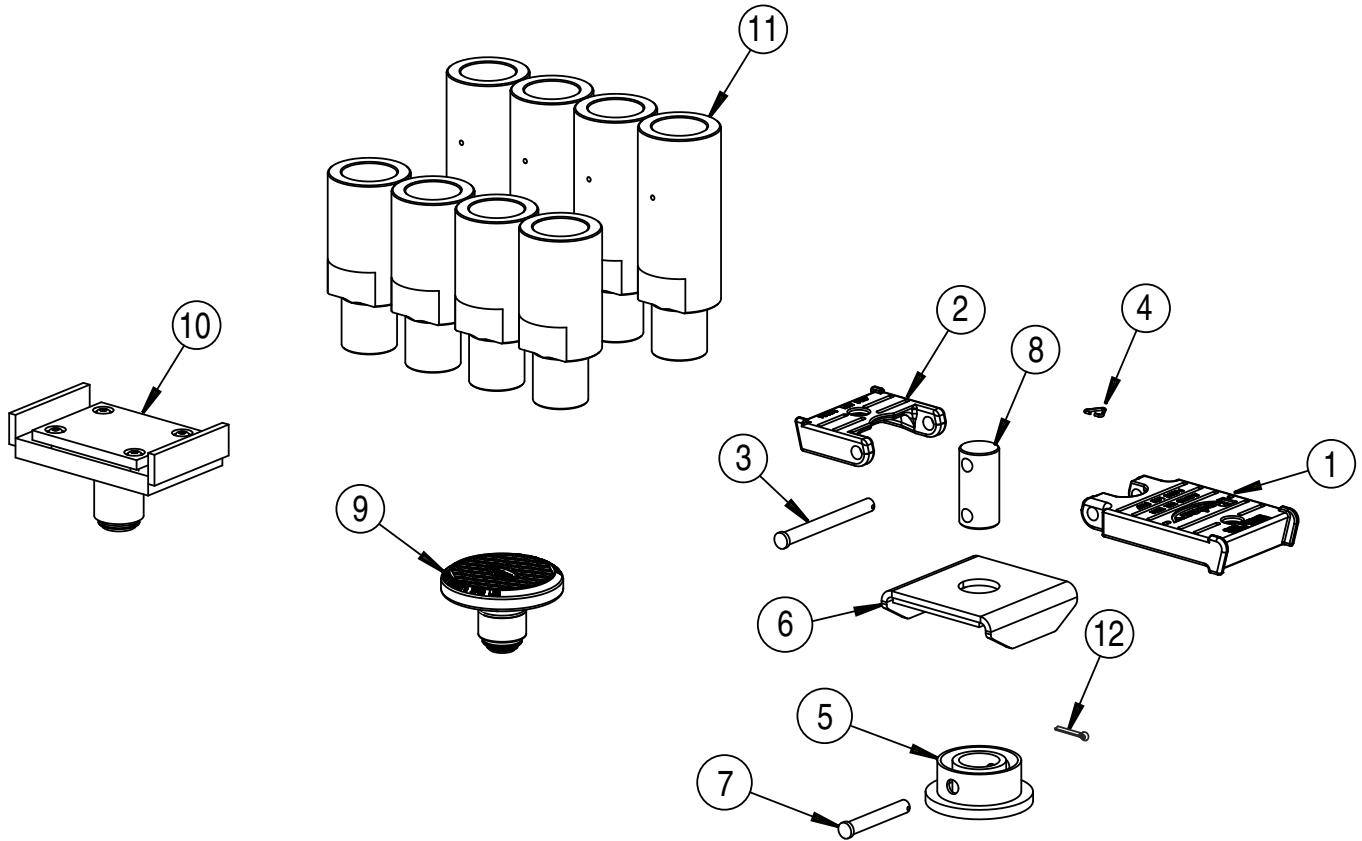

ITEM	DESCRIPTION	PART
1	High Step Adapter	FJ6177
2	Low Step Adapter	FJ6178
3	Adapter Pin	FJ6179
4	3/32" Hog Ring For 1/2" Shaft	FJ671-6
5	Adapter Insert	T120309
6	Load Plate Weldment	T120310
	Load Plate Weldment (used with N2394)	FJ6233
7	Adapter Insert Pin	T130669
8	Swivel Pin	T130668
9	Low Profile Round RA Adapter	FJ6219
10	Truck Adapter	T110564
11	Extension Adapter Kit (Sold Separately)	T100271
12	7/64" x 3/4" Cotter Pin	41205

Locking Latch Detail (Right Column)

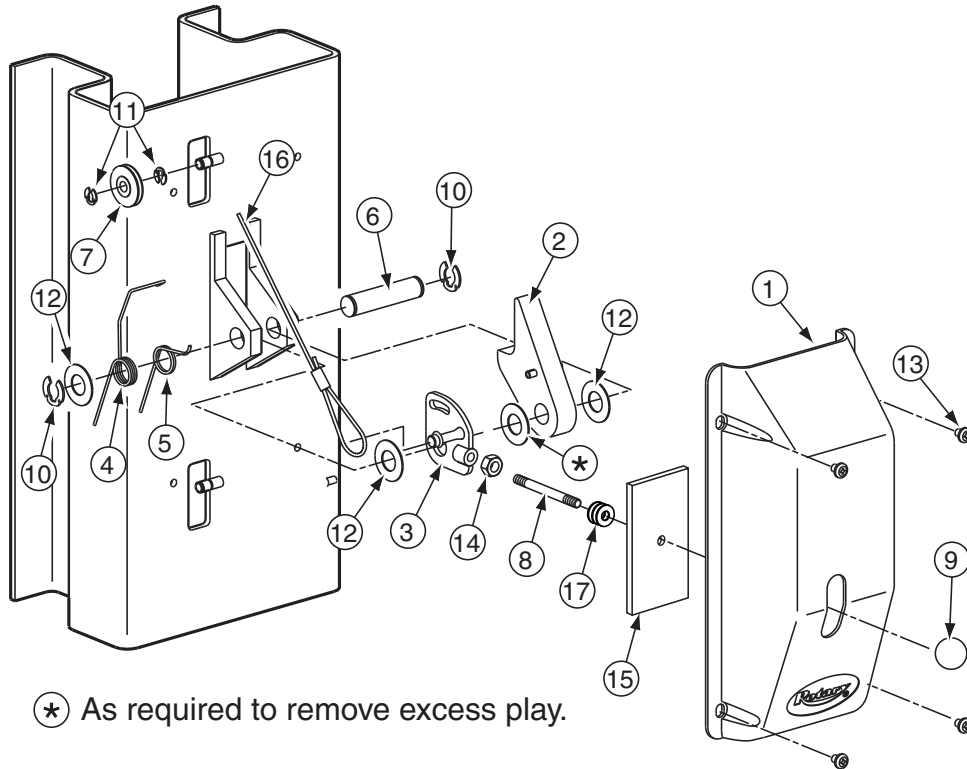

ITEM	DESCRIPTION	PART#
1.	Control Side Cover.....	FJ7452
2.	Locking Latch Dog.....	N616
3.	Control Plate.....	FJ7594-2
4.	Spring.....	FJ7566-10
5.	Spring.....	FJ7382-9
6.	Latch Shaft.....	FJ7382-34
7.	Locking Latch Sheave.....	FJ7322
8.	Handle.....	FJ7382-18
9.	Ball Handle.....	FC134-91
10.	Truarc Klipring #5304-75 for 3/4" Shaft.....	41411
11.	Truarc Klipring #5304-37 for 3/8" Shaft.....	41410
12.	1-1/2" O.D. x 3/4" I.D. x .045" Mach. Bush.....	41388
13.	5/16"-18NC x 3/8" Lg. PHMS.....	40227
14.	3/8" - 16NC Hex Jam Nut.....	40658
15.	Slot Cover.....	N617
16.	Locking Latch Cable.....	FJ7600
17.	3/8" Flat Washer.....	40820

Locking Latch Detail (Left Column)

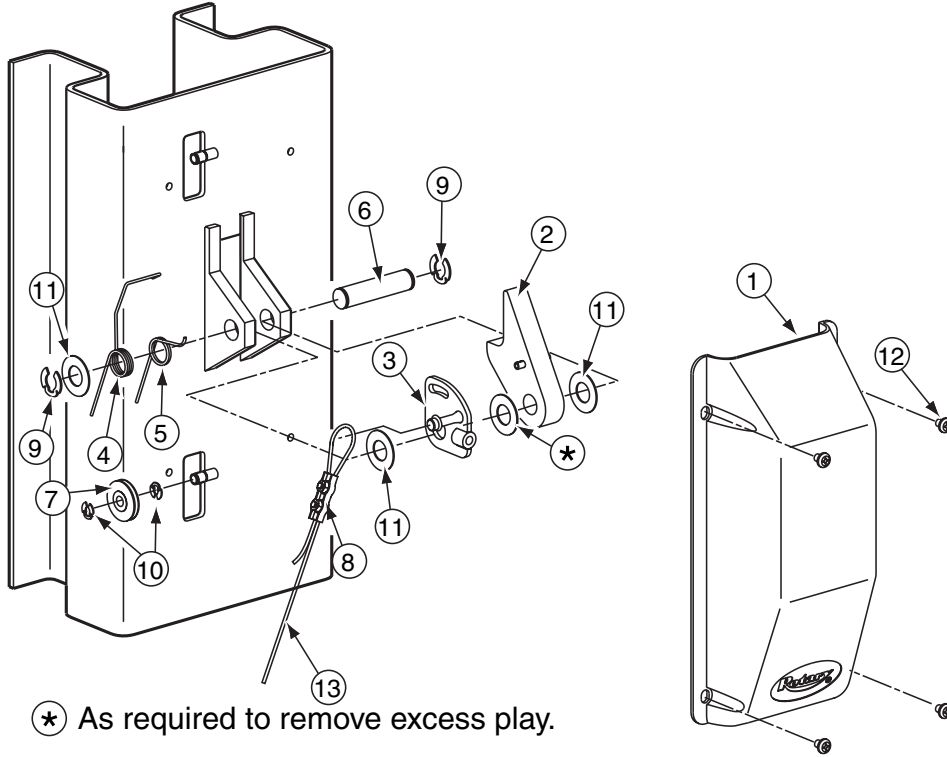

ITEM	DESCRIPTION	PART#
1.	Latch Cover	FJ7451
2.	Locking Latch Dog	N616
3.	Control Plate	FJ7594-2
4.	Spring.....	FJ7566-10
5.	Spring.....	FJ7382-9
6.	Latch Shaft.....	FJ7382-34
7.	Locking Latch Sheave.....	FJ7322
8.	Latch Cable Clamp.....	N63-1
9.	Truarc Klipring #5304-75 for 3/4" Shaft.....	41411
10.	Truarc Klipring #5304-37 for 3/8" Shaft.....	41410
11.	1-1/2" O.D. x 3/4" I.D. x .045" Mach. Bush.....	41388
12.	5/16"-18NC x 3/8" Lg. PHMS.....	40227
13.	Locking Latch Cable	FJ7600

Shockwave Detail

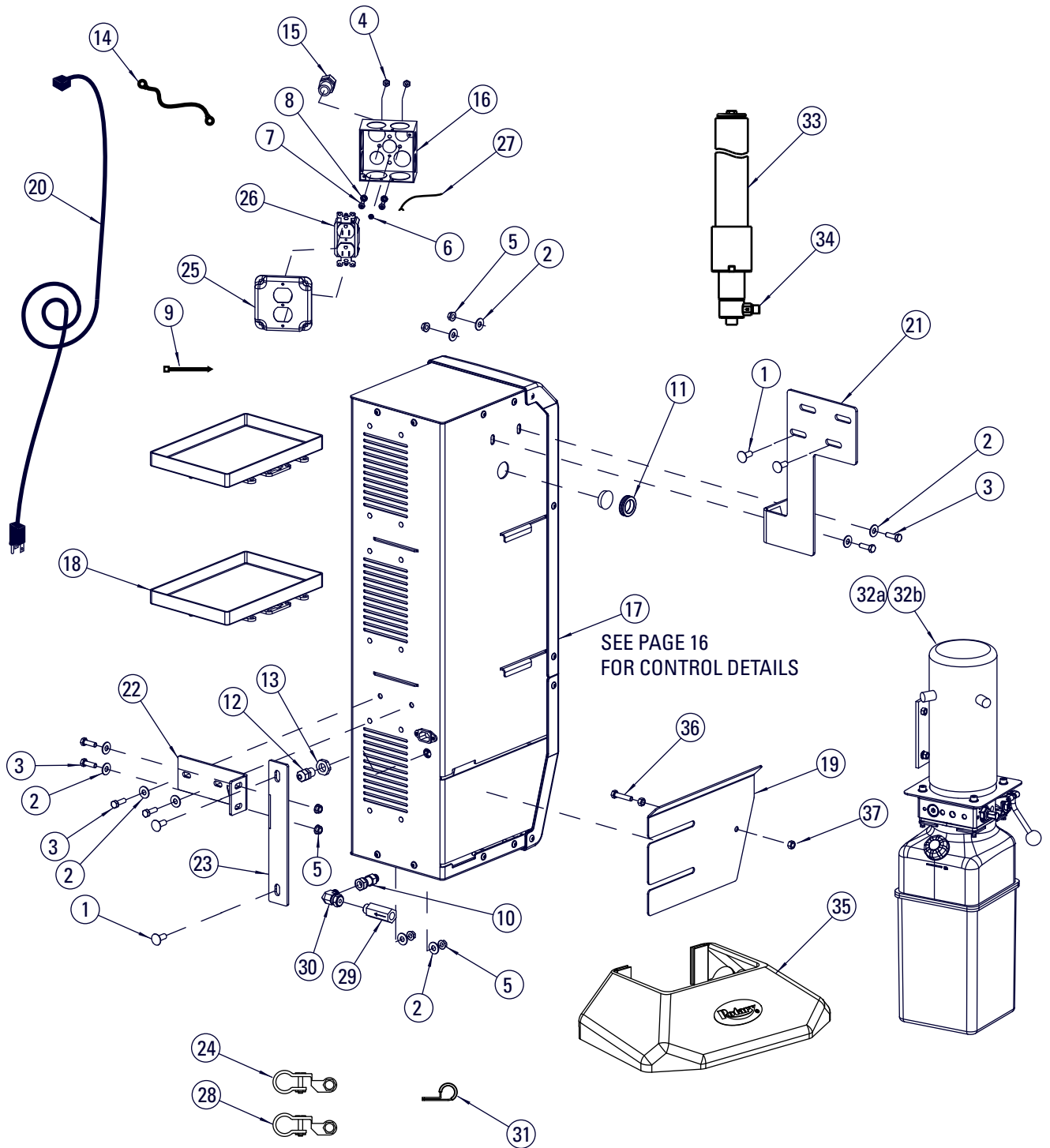

DC CONTROL MOUNTING

Shockwave Detail

ITEM	PART NO.	DESCRIPTION
1	40167	3/8"-16NC x 1" Lg. CAR. BOLT, Gr. 5, PLTD.
2	40217	5/16" USS FLAT WASHER, PLTD
3	40221	5/16"-18NC x 1" Lg HHCS, GRD5 PLTD
4	40650	#12-24NC HEX NUT, PLTD
5	40678	5/16"-18NC HEX FLGD WZLOCK NUT, PLTD
6	FA997-1	#10-32 x 1/4" Lg. HEX WHSFTS, PLTD, COLORED GREEN
7	41526	#12-24NC x 3/4" Lg. PHIL. PHMS, PLTD
8	41527	#12 EXT TOOTH LW, PLTD
9	629888	TY-RAP CABLE TIE, NYLON, BLACK, 11 1
10	EFX60010319	ADAPTER, STRAIGHT THREAD/ SWIVEL (ORB/ORFS 6X6)
11	FA7180-31	WIRE GROMMET
12	FA7189-14	3/8" NPT STRAIN RELIEF
13	FA7189-15	3/8" NPT LOCKNUT
14	FA7616	BATTERY-BATTERY CABLE
15	FA7958-28	CORD GRIP
16	FA997	JUNCTION BOX
17	FA966	DC CONTROL ASSEMBLY
18	FA966-16	BATTERY TRAY
19	FA966-47	BATTERY CABINET 2-POST SPLASH SHIELD
20	FA966-51	10FT UNIVERSAL POWER CORD (NEMA 5-15P TO IEC320C13)
21	FA966-55	BATTERY CABINET UPPER MOUNTING BRKT WELD
22	FA966-56	BATTERY CABINET MOUNTING BRKT WELD
23	FA966-57	BATTERY CABINET MOUNTING COLUMN BRKT WELD
24	FA979	POSITIVE BATTERY TERMINAL END
25	FA980-1	DUPLEX RECEPTACLE COVER 4" SQUARE BOX
26	FA980-2	DUPLEX FEMALE RECEPTACLE
27	FA980-3	GROUND WIRE
28	FA981	NEGATIVE BATTERY TERMINAL END
29	FJ71003	FLOW REGULATOR
30	FJ71007	MALE ORFS x FEMALE ORFS SWIVEL ELBOW
31	FJ7669	COLUMN HOSE CLAMP
32a	P3577	DC POWER UNIT - PAD LIFT
32b	P3579	DC POWER UNIT - ARM LIFT
32c	P3586	DC POWER UNIT - SPO12
33	N3151Y	HYDRAULIC CYLINDER
34	FJ7352-3	ADAPTER
35	N539	BASE PLATE COVER (FOR SPOA10 & SPO10 MODELS ONLY)
36	40271	5/16"-18NC x 1-1/2" HHCS FULL THREAD
37	40670	5/16"-18NC HEX NUT

Shockwave Detail

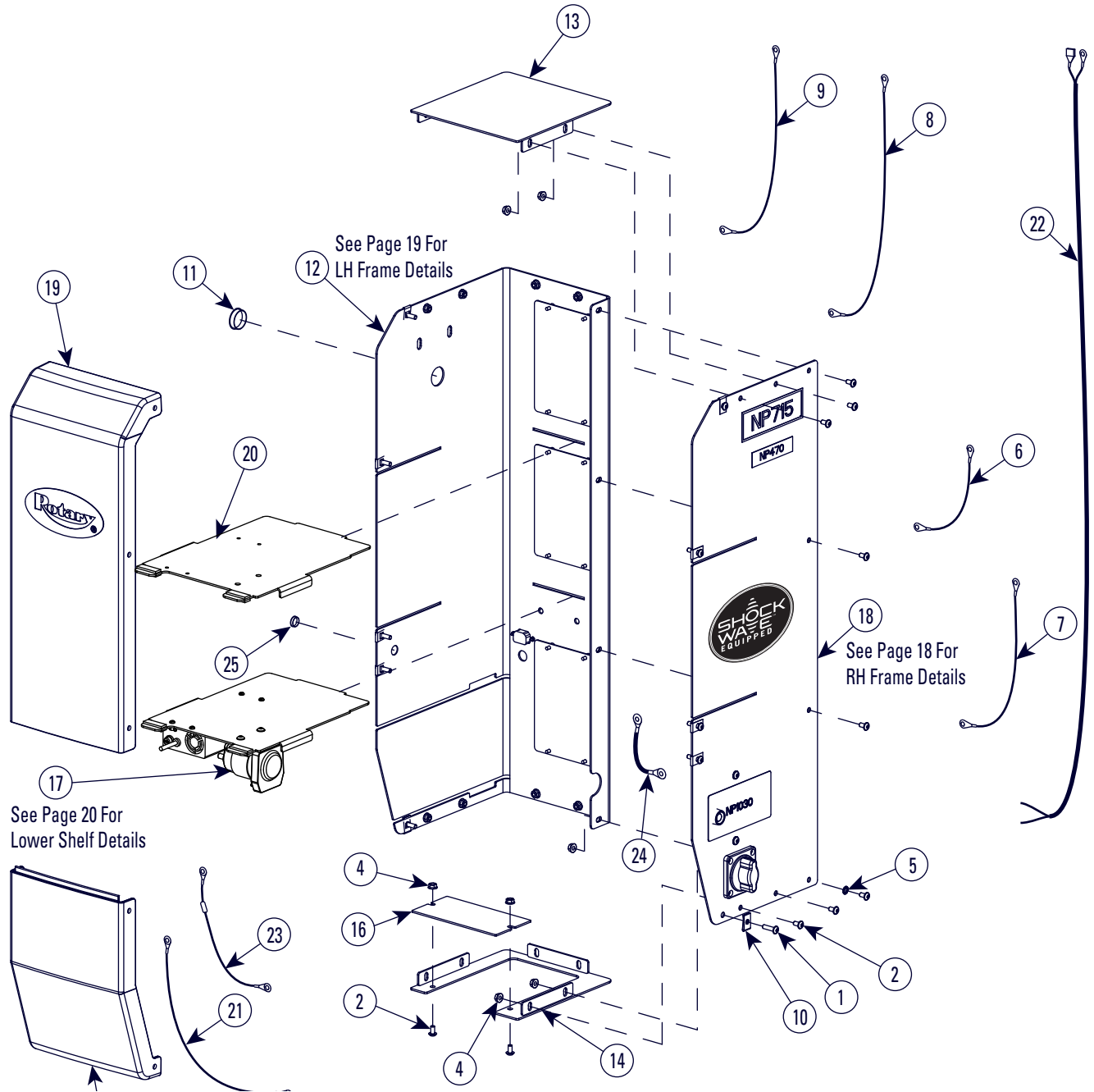

Shockwave Detail

DC CONTROL		
ITEM	PART NO.	DESCRIPTION
1	40077	1/4"-20NC x 1" Lg FLGD HEX SOC BHCS, GRD2
2	40094	1/4"-20NC x 1/2" Lg FLGD HEX SOC BHCS
3	NA	NA
4	40641	1/4"-20NC HEX FLGD WZLOCK NUT, PLTD
5	40779	1/4" EXT TOOTH LW
6	FA7618	DISCONNECT-FUSE CABLE
7	FA7619	FUSE-CONTACTOR CABLE
8	FA7667	BATTERY-DISCONNECT CABLE
9	FA7668	BATTERY-MOTOR CABLE
10	FA966-22	CLIP-ON NUT
11	FA966-34	1-1/4" HOLE PLUG
12	FA966-37	BATTERY CABINET LH FRAME ASSY
13	FA966-39	BATTERY CABINET TOP COVER WELDMENT
14	FA966-42	BATTERY CABINET BOTTOM COVER WELDMENT
15	FA966-45	BATTERY CABINET FRONT BOTTOM COVER
16	FA966-46	BATTERY CABINET SMALL BOTTOM COVER
17	FA966-48	BATTERY CABINET LOWER SHELF ASSEMBLY
18	FA986-1	BATTERY CABINET RH FRAME ASSEMBLY
19	FA966-50	BATTERY CABINET FRONT TOP COVER ASSY
20	FA966-58	BATTERY CABINET SHELF WELD
21	FA970	CONTACTOR HARNESS
22	FA971	OVERHEAD HARNESS
23	FA978	DISCONNECT HARNESS
24	FA982	GROUND WIRE
25	FA966-60	TRANSPARENT HOLE PLUG

Shockwave Detail

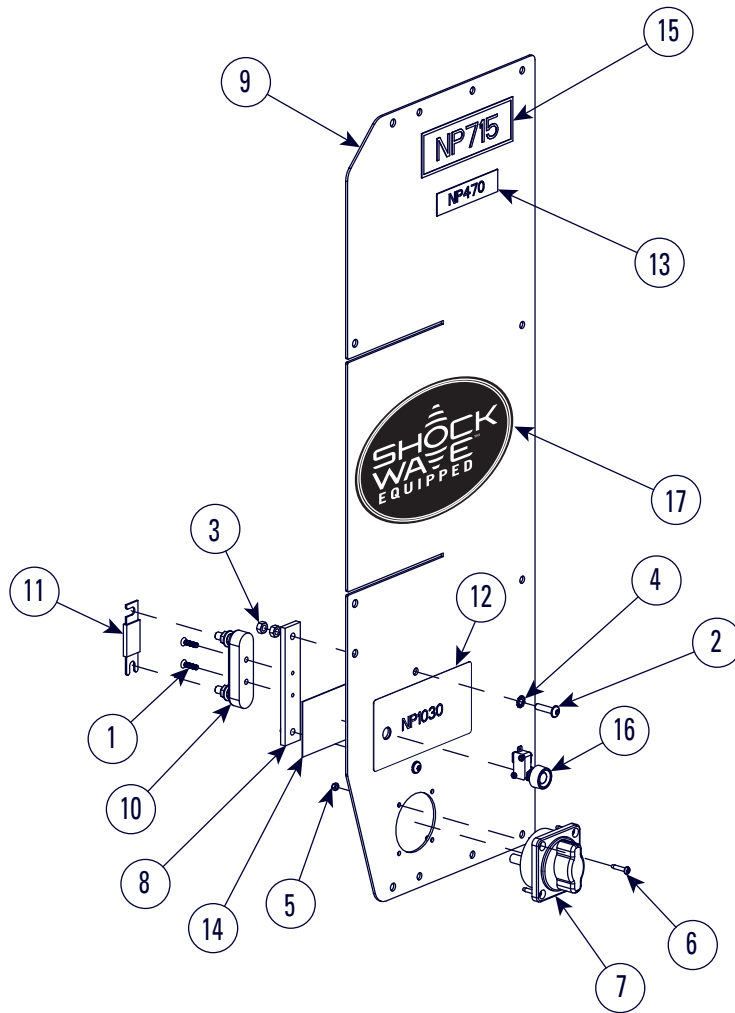

RIGHT HAND FRAME ASSEMBLY		
ITEM	PART NO.	DESCRIPTION
1	40004	#10-24 x 5/8 PFHMS, McMASTER-CARR # 90471A315 or EQUAL
2	40077	1/4"-20NC x 1" Lg FLGD HEX SOC BHCS, GRD2
3	40627	1/4"-20NC HEX NUT, PLTD
4	40779	1/4" EXT TOOTH LW
5	450957	#8-32NC NYLON LOCKNUTS
6	40022	#8-32NC X 1/2" Lg PHMS
7	FA7958-4	DC DISCONNECT SWITCH
8	FA966-8	FUSE HOLDER MOUNTING BRACKET
9	FA986-10	BATTERY CABINET RH FRAME
10	FA975	FUSE HOLDER
11	FA975-1	350 AMP FUSE
12	NP1030	PUSHBUTTON NAMEPLATE
13	NP470	MOTOR LOCATION WARNING LABEL
14	NP692	NAMEPLATE
	NP1066	NAMEPLATE
15	NP715	NAMEPLATE
16	P1483	LIMIT SWITCH ASSEMBLY
17	NP1067	SHOCKWAVE DECAL

Shockwave Detail

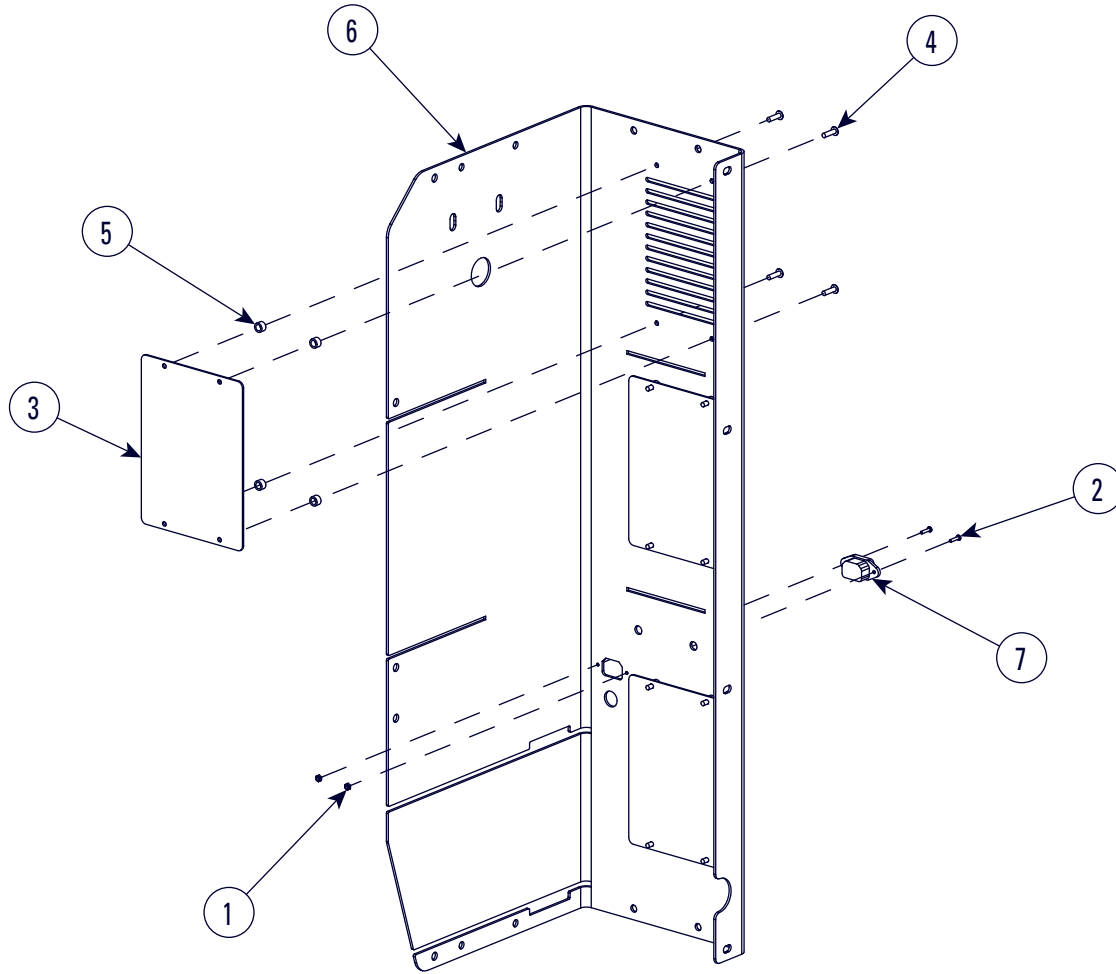

LEFT HAND FRAME ASSEMBLY		
ITEM	PART NO.	DESCRIPTION
1	41628	#4-40 NYLON INSERT LOCKNUT MMC #90633A005
2	796443	#4-40 x 1/2 Lg. PHMS, PLTD
3	FA966-17	SPLASH SHIELD
4	FA966-18	DOMED HEAD RIVET
5	FA966-21	SPACER
6	FA966-52	BATTERY CABINET LH FRAME FORMING
7	FA983	CHARGER INTERNAL POWER CORD

Shockwave Detail

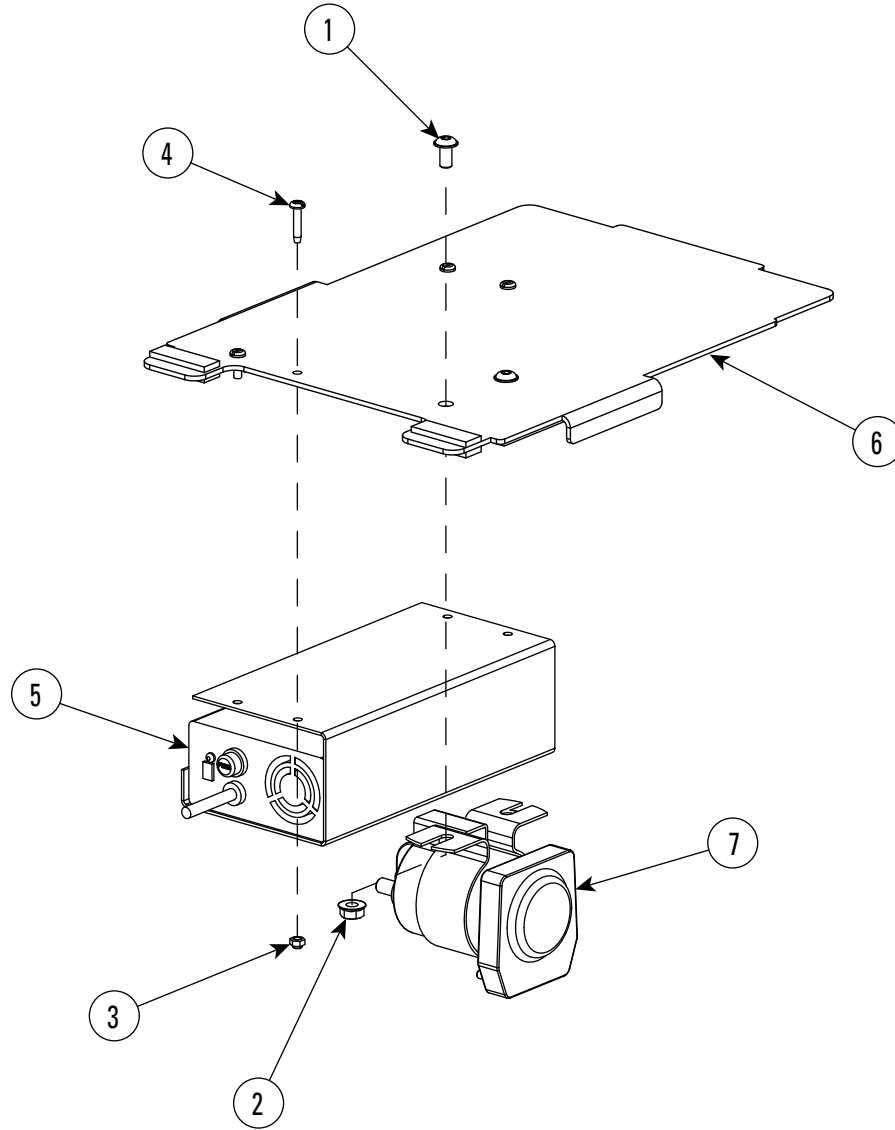

LOWER SHELF ASSEMBLY		
ITEM	PART NO.	DESCRIPTION
1	40094	1/4"-20NC x 1/2" Lg FLGD HEX SOC BHCS
2	40641	1/4"-20NC HEX FLGD WZLOCK NUT, PLTD
3	450957	#8-32NC NYLON LOCK NUT
4	40022	#8-32NC x 1/2" LG. PHMS
5	FA966-62	24V 8A CHARGER ASSEMBLY
6	FA966-58	BATTERY CABINET SHELF WELD
7	FA976	DC CONTACTOR

Cylinder Hose Adapter Detail

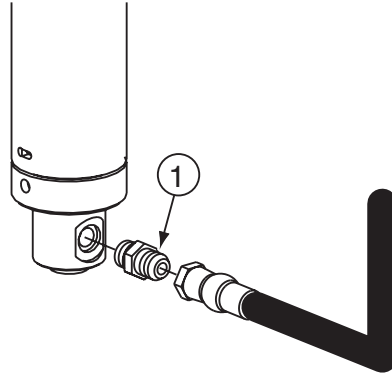

ITEM	DESCRIPTION	PART#
1.	Straight Adapter.....	FJ7352-3

DATE	REV.	CHANGE MADE
07/18/05	-	New (700 Series) instructions.
12/6/05	B	Added S model motor voltage information.
01/17/06	C	Updated Locking Latch Cable part number.
08/10/06	D	Updated power unit part numbers and added barcode.
08/29/07	E	Combined 500 and 700 Series parts breakdowns
09/10/07	F	Updated capacitor box part numbers
01/24/08	G	Added SPOA10 Wide Supplemental Parts
08/19/08	H	Removed SPOA10 Wide Supplemental Parts-Added to IN20500 Install Added new SPOA10/SPO10 Part Numbers
2/17/09	J	Revision I skipped - Added SPOA10 5BX series arms.
7/31/09	K	Updated cylinder part numbers.
8/06/09	L	Added 3-Stage Arm Detail
8/03/10	M	Updated Corporate Address Information
2/10/11	N	Remove the old arms for the 50X, R8X, 51X, and 5NX Series models.
6/07/11	P	Added SPO10 5GX Series and SPOA10 5TX Series Arms. Changed standard overhead hose to N3103 and updated notes on page 4.
6/27/11	R	Bring revision level up-to-date to match change orders.
7/7/11	S	Updated cover graphic removing the NP93 display.
3/8/12	U	Updated latch hardware detail.
4/9/12	V	Added SPOA7 hybrid arms.
8/14/12	W	Added shim detail updates.
1/28/13	X	Added seismic base plates
4/17/13	Y	Added Shockwave detail.
3/4/14	Z	Added 800 Series detail and Trio Arms.
2/26/15	AA	Added 3Ø Control Box Details.
5/13/15	AB	Cylinder N3156 was N380.

Rotary World Headquarters
2700 Lanier Drive
Madison, IN 47250, USA
www.rotarylif.com

North America Contact Information

Tech. Support:
p 800.445.5438
f 800.578.5438
e userlink@rotarylif.com
Sales:
p 800.640.5438
f 800.578.5438
e userlink@rotarylif.com

World Wide Contact Information

World Headquarters/USA: 1.812.273.1622
Canada: 1.905.812.9920
European Headquarters/Germany: +49.771.9233.0
United Kingdom: +44.178.747.7711
Australasia: +60.3.7660.0285
Latin America / Caribbean: +54.3488.431.608
Middle East / Northern Africa: +49.771.9233.0

© Vehicle Service GroupSM

Printed in U.S.A., All Rights Reserved. Unless otherwise indicated, ROTARY, and all other trademarks are property of Dover Corporation and its affiliates.

