

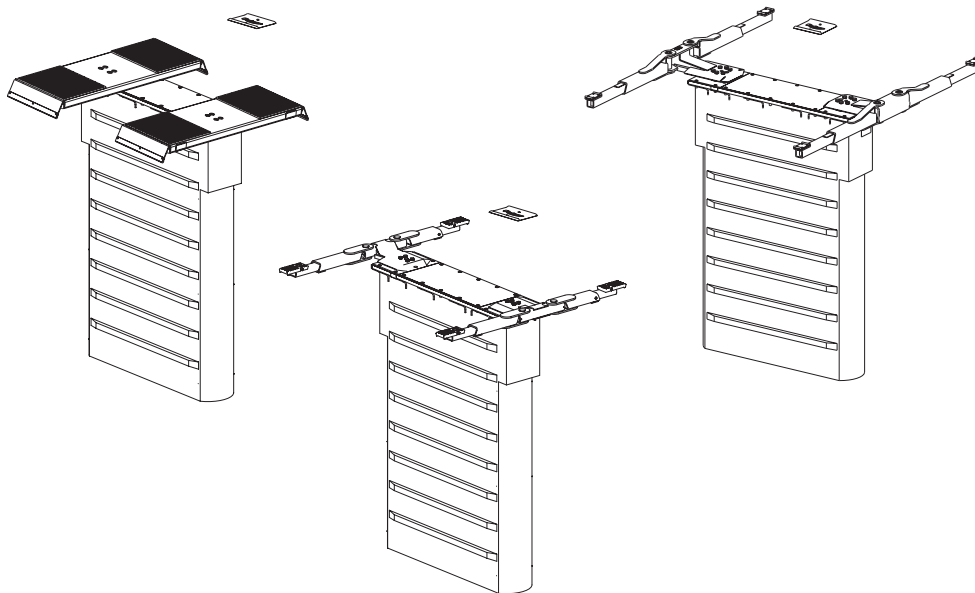

SL210/SL212 (500 Series)

SL210 Fixed Pad Capacity 9,000 lbs. and 10,000 lbs.
SL210 Capacity 10,000 lbs.
SL212 Capacity 12,000 lbs.



P
A
R
T
S

B
R
E
A
K
D
O
W
N

IMPORTANT: When ordering parts or requesting service always give exact model and power unit serial number. Model number is shown on nameplate attached to air lock release valve. Power unit serial number is located on side of power unit.

OWNERS RECORD
Complete information
at right and keep in
a safe place.

Date Installed _____

Installed in Bay # _____

Power Unit Serial # _____

Power Unit Model # _____

Lift Serial # _____

Lift Model # _____

NOTE: For replacement parts -See your nearest Rotary Parts Distributor.



1	1/2"-13NC x 2" Self Tap, Grade5, Plated.....	40268	58	Capacitor Box (with Drum Switch) All Voltages.....	FA7203
2	Cover Plate	T120209		M5 x 10 PHMS, Plated.....	40275
3	One Piece Gasket.....	T140163	59	Plunger.....	T120161
4	1" NPT Pipe Plug.....	12011	60	Bearing.....	T140148
5	Zerk Fitting L#5000 1/8" Pipe.....	T140007	61	Wiper Seal.....	T140118
6	Guide Barrel Assembly.....	T110175	62	Wheel Spotting Dish Kit	FF729
7	1-1/8"-7NC x 3" HHCS, Grade 5, Plated	40606		Wheel Spotting Dish	FF729-1
8	1/2"-13NC x 2-3/4" HHCS, Grade 5	40341		Anchor	FJ7659-2
9	9/16" Internal Tooth Lockwasher, Plated	40998	63	1/2"-13NC x 1-1/2" HHCS Grade 5	40302
10	Male Connector for Nylon Tube	FC5225-47	64	End Anchoring Frame Weldment	T120285
11	Latch Bar Plate.....	T130342	65	Side Anchoring Frame Weldment.....	T120286
12	1-1/8" Internal Tooth Lock Washer, Plated	40608			
13	1-1/8"-7NC Hex Nut, Plated	40607			
14	1/4" NPT x 1/4" Push Fit Swivel Elbow	FC5341-90			
15	Union.....	FC5225-98			
16	Number Not Used	----			
17	Number Not Used	----			
18	Tie Channel.....	T130345			
19	Latch Bar	T130341			
20	Hose Bracket Assembly	T120158			
21	Vertical Hose Assembly.....	T110281			
22	Bulkhead Adapter.....	T140132			
23	Plunger Hose	T140169			
24	SS Bulkhead Union Tee	T140134			
25	Number Not Used	----			
26	5/16"-18NC Flanged Whizlock Nut.....	40678			
27	Hose Clip.....	FJ7499			
28	Equalizer	T110176			
29	5/8" Helical Spring Lockwasher, Plated.....	40961			
	5/8"-11NC x 2-1/2" Hex SHCS	40343			
30	Anchor Frame Side	T120198			
31	Anchor Frame End	T120197			
32	Containment (with Uniseal hole drilled).....	T140202			
33	2" Uniseal	T140023			
34	Frame Weldment.....	T120266			
35	1/2"-13NC x 1" HHCS, Grade 5	40261			
36	Guide Barrel Fitting Kit	T100147			
37	1/4" Nylon Tube (26" long)	T140213			
38	Union Tee	FC5225-46			
39	Lift Bar Weldment.....	T120214			
40	1/2"-13NC x 1-1/4" Countersunk SHCS	40337			
41	1/2"-13NC Hex Flanged Whizlock Nut, Plated	40704			
42	#8-32NC Nylon Insert Lock Nut	40649			
43	Brass Filter	T140075			
44	Swivel Elbow	T140074			
45	Air Lock Valve.....	T140073			
46	#8-32NC x 1-1/2" Rnd Head Machine Screw.....	40007			
47	Power Unit Wall Bracket.....	T120020			
48	5/16"-18NC x 1-1/2" HHCS Zinc Plated	40271			
49	5/16" Ext. Tooth Lock Washer Plated	40854			
50	5/16" Push Nut	FC5209			
51	Air Lock Valve Mounting Bracket.....	T130187			
52	1/4" Push-In 1/4" NPT Female Fitting.....	T140081			
53	Filter	FA3134-12			
54	Air Lock Valve Handle	T140119			
55	Elbow	FJ7224			
56	SL210 Power Unit (Standard And 10,000 lbs. Fixed Pad)				
	1Ø 60 Hz.	*P1350/P3350			
	3Ø 50/60Hz.	*P1346/P3346			
	3Ø 60Hz./575V.....	*P1354/P3354			
	SL210 Power Unit (9,000 lbs. Fixed Pads)				
	1Ø 60 Hz.	*P1352/P3352			
	3Ø 50/60Hz.	*P1353/P3353			
	3Ø 60Hz./575V.....	*P1356/P3356			
	SL212 Power Unit				
	1Ø 60 Hz.	*P1302/P3302			
	3Ø 50/60Hz.	*P1347/P3347			
	3Ø 60Hz./575V.....	*P1359/P3359			
57	5/16"-18NC Hex Nut.....	40670			

* Two different power units were used. Please verify your exact model number before ordering replacement parts.

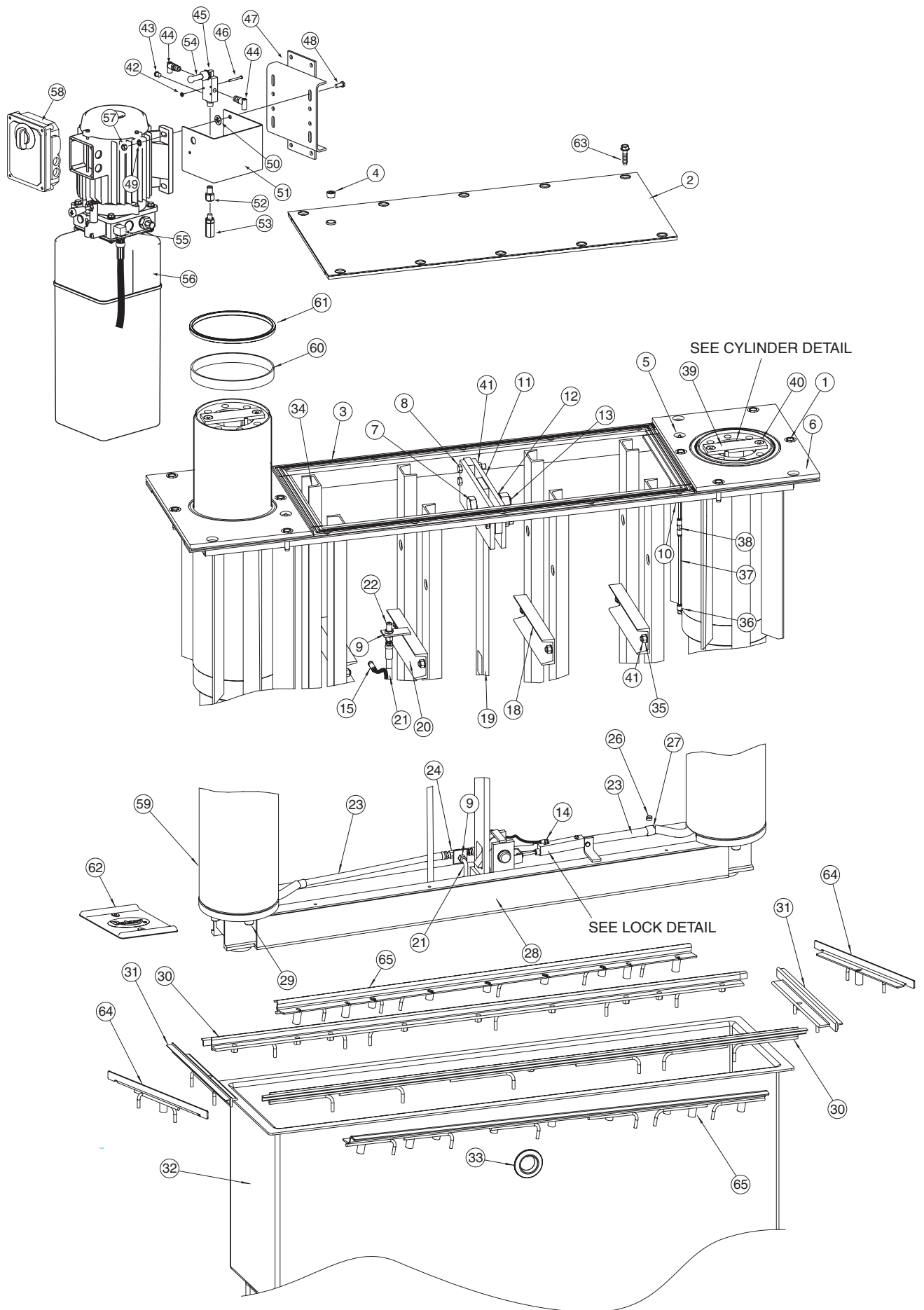

AIR LOCK RELEASE VALVE DETAIL		
ITEM NO.	DESCRIPTION	PART NO.
1	#8 SAE Flat Washer	40788
2	1/4" Tubing	FC2230-2
3	Nameplate	NP280
4	Control Ass'y.	T140073
5	Swivel Elbow	T140074
6	Filter / Muffler	T140075
7	Air Lock Handle	T140119
8	Control Bracket 1Ø	S110274
	Control Bracket 3Ø	S110286
9	#8-32NC x 1-1/2" PHMS	40007
10	#8-32NC Nylon Locknut	40649
11	M5 x 0.8 PHMS 3Ø	41549

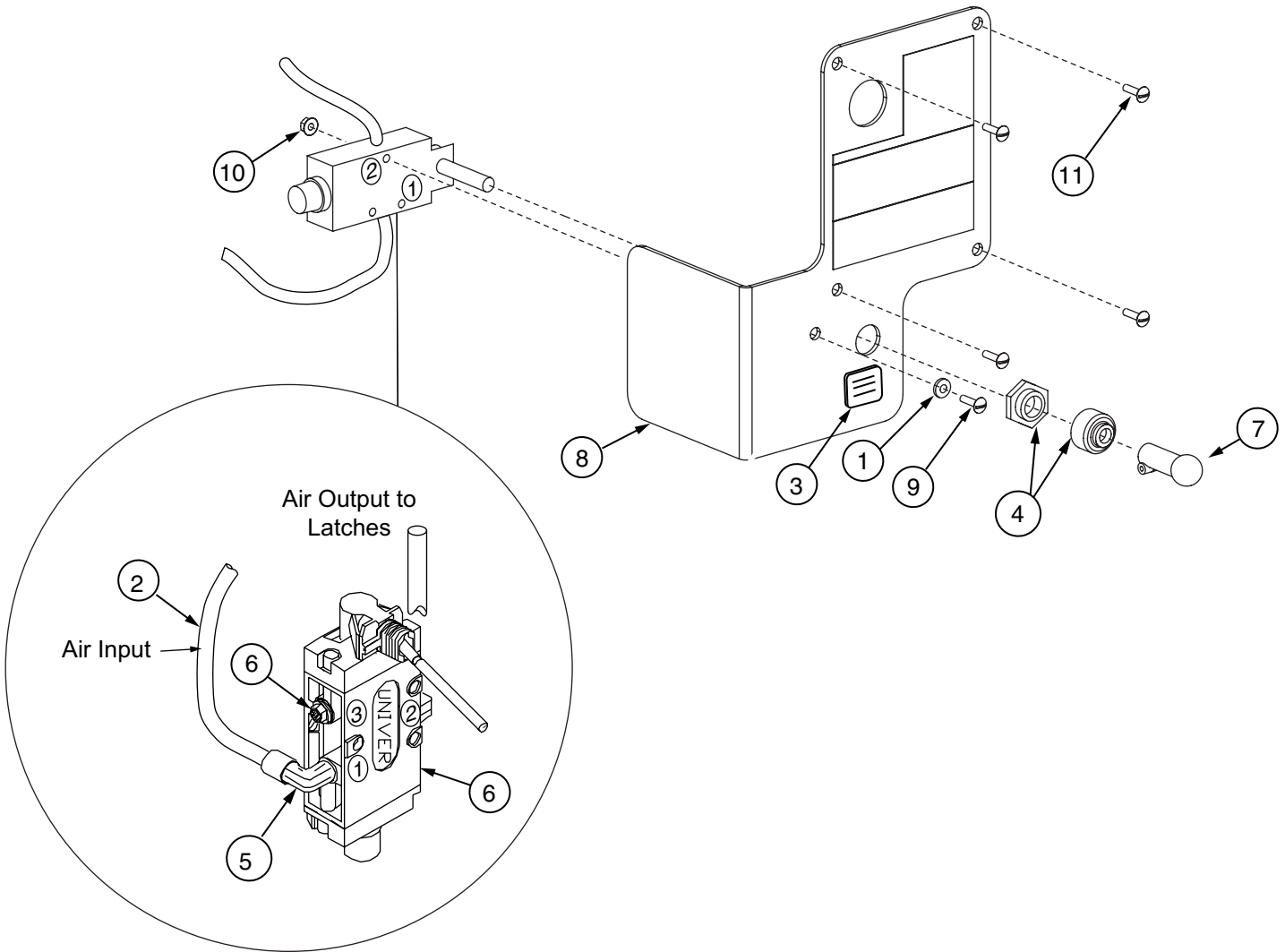

CYLINDER DETAIL

ITEM#	DESCRIPTION	PART#	QTY.
1	Hydraulic Cylinder	N367	2
2	Plunger Hose	T140169	2
3	Hose Support Tube	T140166	2

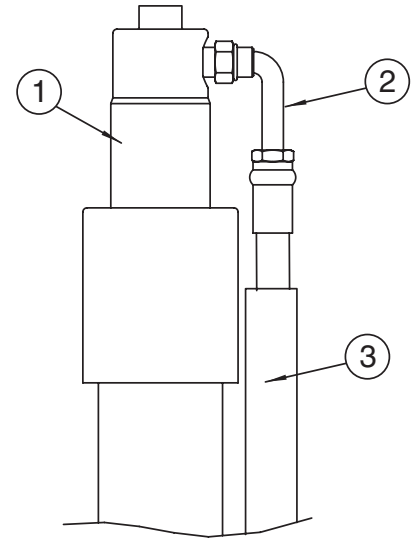

LOCK DETAIL

ITEM#	DESCRIPTION	PART#	QTY.
1	Latch Shaft.....	T130350	1
2	Locking Latch	T130348	1
3	Latch Clevis Pin, Plated	T140135	1
4	3/32" x 3/4" Lg. Cotter Pin	41168	1
5	1/4"-28NF Nylon Insert Locknut, Plated....	40611	2
6	Number Not Used	----	
7	Number Not Used	----	
8	1/4"-20NC x 1-1/4" HHCS, Grade 2	40115	1
	1/4"-20NC Hex Nylon Insert Locknut	40642	1
9	Air Cylinder	T140062	1
10	Clevis	T130349	1
11	Retaining Ring TRUARC #5304-125.....	41417	2

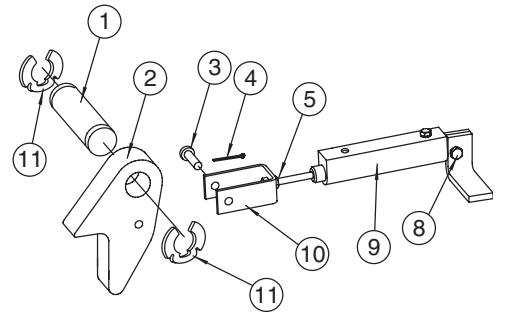

SL212 ARM DETAIL

ITEM#	DESCRIPTION	PART#	QTY.
1	4" Extension	FJ6143	4
	8" Extension	FJ6144	2
2	Adapter Assembly	FJ6158	4
3	Yoke Weldment	T120152	2
4	Swing Arm.....	T110116	4
5	7/8"-9NC x 3-1/2" HHCS, Grd 5, Plated	40498	12
	7/8" External Tooth Lockwasher, Plated	41072	12
6	Arm Pin	T120153	4
	3/16" x 3" Cotter Pin	41253	4
7	Extension Rack	FJ6145	2

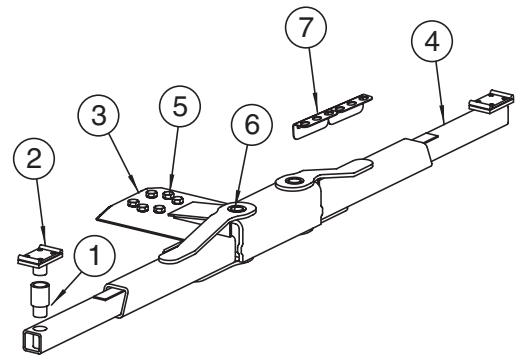

SL210 ARM DETAIL

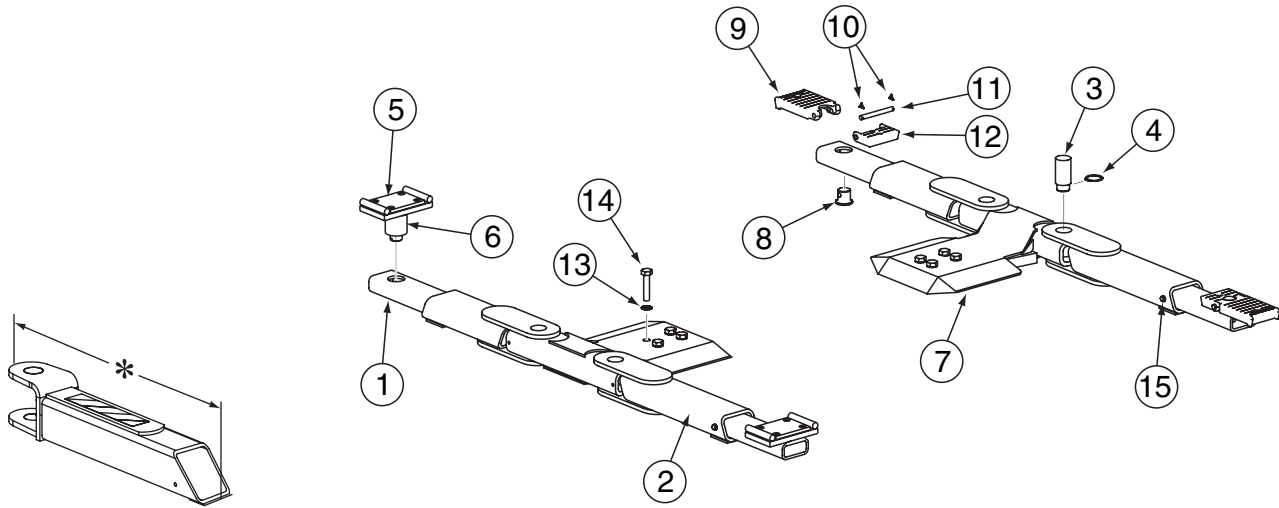

Swing Arm Superstructure

- * Extra Short Arm distance = 21-7/8" Ref.
- * Short Arm distance = 23-7/8" Ref.
- * Long Arm distance = 28-1/8" Ref.

ITEM	DESCRIPTION	PART #
1	*Short Arm Assembly (Rubber Pad Adapters).....	T110372
	*Short Arm Assembly (Flip-Up Adapters)	T110371
	*Extra Short Arm Assembly (Rubber Pad Adapters)	T110374
	*Extra Short Arm Assembly (Flip-Up Adapters)	T110373
2	*Long Arm Assembly (Rubber Pad Adapters)	T110370
	*Long Arm Assembly (Flip-Up Adapters).....	T110369
3	Arm Pin.....	T130451
4	Arm Pin Retaining Ring	T140168
5	Rubber Pad.....	FJ6158-4
6	Adapter Assembly.....	FJ6182
7	Yoke	T120221
8	Adapter Swivel Pin.....	FJ79-6
9	High Step Adapter	FJ6177
10	3/32" Hog Ring for 1/2" Shaft	FJ671-6
11	Adapter Pin.....	FJ6179
12	Low Step Adapter	FJ6178
13	7/8" External Tooth Lockwasher, Plated.....	41072
14	7/8"-9NC x 3-1/2" HHCS, Grd 5, Plated.....	40498
15	3/8"-16NC x 5/8" HHCS Grade 8 Plated	40155
	3/8" Internal Tooth Lockwasher	40843

SL210 3-STAGE ARM DETAIL

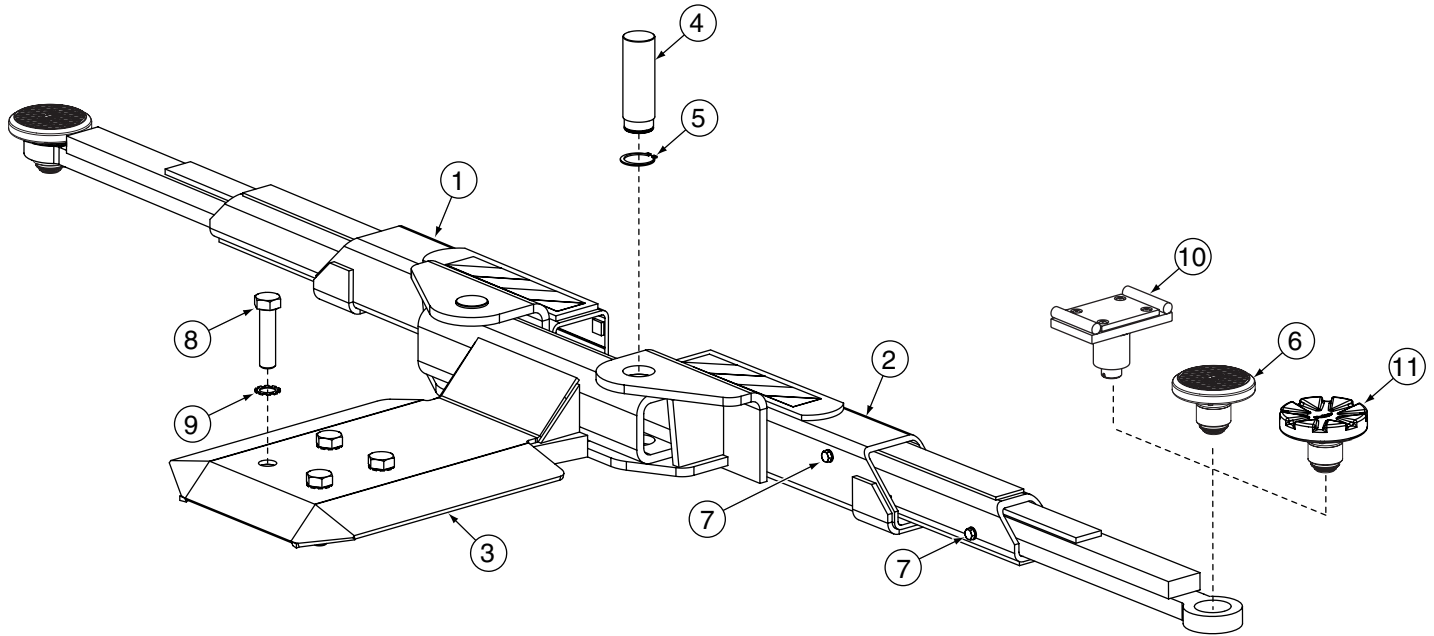

ITEM#	DESCRIPTION	PART#	QTY.
1	R. H. 3-Stage Arm	T110320	2
2	L. H. 3-Stage Arm.....	T110319	2
3	Yoke (without Stop Bar).....	T120256	2
4	Arm Pin	T130451	4
5	Arm Pin Retaining Ring.....	T140168	4
6	3-Stage Adapter Assembly (Low Profile)	FJ6202	4
7	3/8"-16NC x 5/8" HHCS, Gr. 8, Plated.....	40155	8
	3/8" Internal Tooth Lockwasher	40843	8
8	7/8"-9NC x 3-1/2" HHCS, Gr. 5, Plated	40498	8
9	7/8" External Tooth Lockwasher, Plated	41072	8
10	Truck Adapter (Optional, Sold Separately).....	FJ6182	4
11	3-Stage Adapter Assembly	FJ6191	4

SL210 FIXED PAD SUPERSTRUCTURE DETAIL

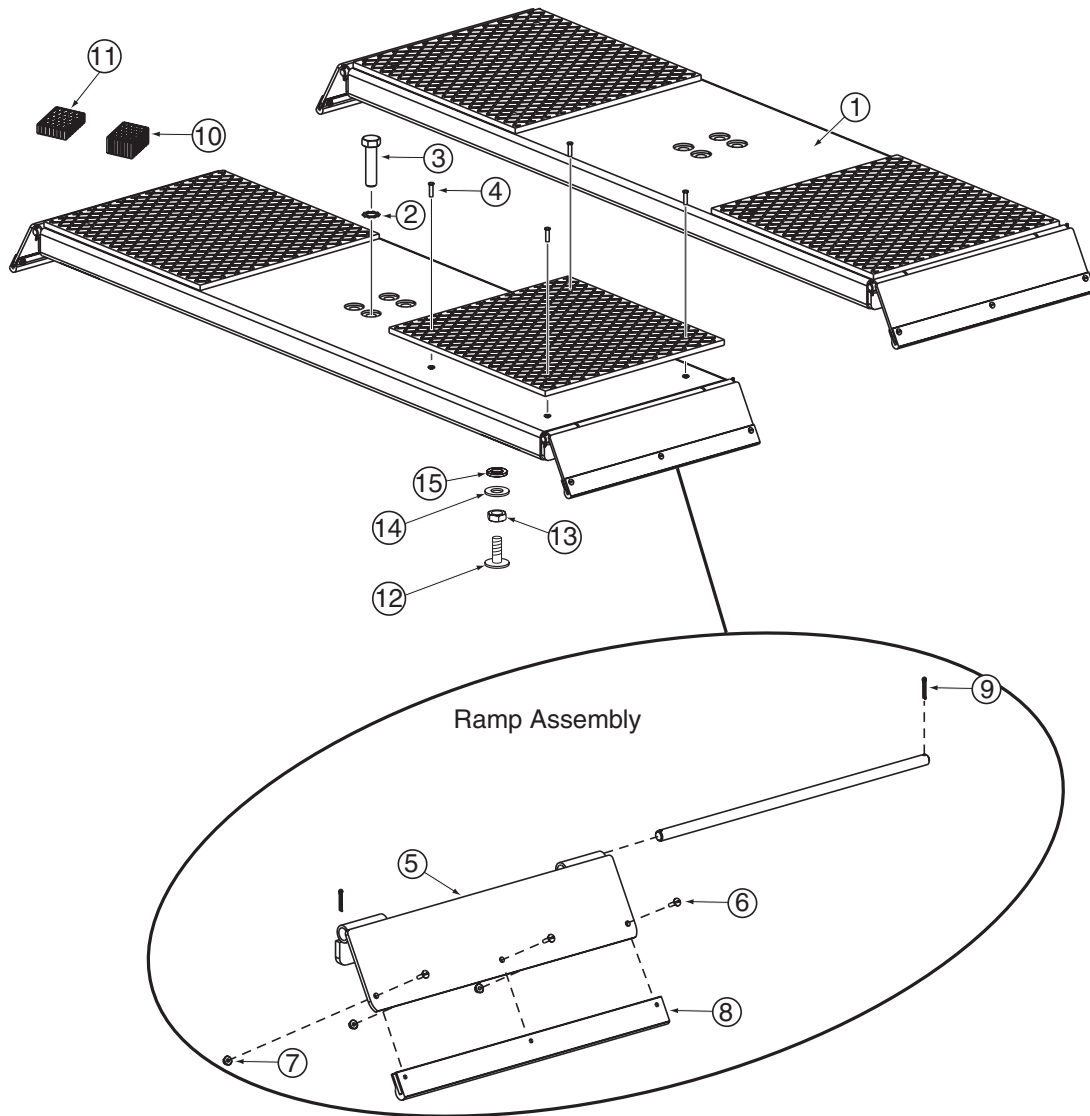

ITEM#	DESCRIPTION	PART#	QTY.
1	Fixed Pad Assembly.....	T110323	2
2	7/8" External Tooth Lockwasher, Plated	41072	8
3	7/8"-9NC x 3-1/2" HHCS, Grd 5, Plated	40498	8
4	1/4" x .475 Blind Rivet	40174	16
5	Ramp Weldment.....	N2135	2
6	#10-24NC x 3/4" SLTRUSSHMS Plated....	40050	12
7	#10-24NC FI Whizlock Nut Plated.....	40633	12
8	20" Chock Slide	FC134-33	4
9	5/32" x 1" Cotter Pin	41202	8
10	3" Rubber Adapter Pad	FJ2428	8
11	1-1/2" Rubber Adapter Pad	FJ2427	4
12	Adjustment Screw	FJ7465-15	4
13	3/8"-16NC Hex Jam Nut, Plated.....	40658	4
14	3/8" USS Flat Washer, Plated	40820	4
15	3/8" Helical Spring Lockwasher, Plated.....	40498	4

NOTES:

NOTES:

NOTES:

DATE	REV.	CHANGE MADE
07-14-05	G	Added Wheel Spotting dish (FF729), Truck Adapter (FJ6182) and Low Profile Adapter (FJ6202). 40678 (whizlock nut) was 40227, T140202 (Containment) was T140124, T120266 (Frame Weldment) was T120212, 41168 (Cotter Pin) was 41168, 40611 (Nylon Insert Locknut) was 40648.
01-05-06	H	Updated air line detail.
08-30-06	J	Added bar code and updated power unit part numbers. Rev. I skipped.
01-08-07	K	Added 10,000 lb. fixed pad detail
01-07-07	L	Updated hardware part number - Item 62.
04-25-07	M	Updated arm details

Rotary World Headquarters

2700 Lanier Drive
 Madison, IN 47250, USA
www.rotarylif.com

North America Contact Information

Tech. Support: p 800.445.5438
 f 800.578.5438
 e userlink@rotarylif.com
 Sales: p 800.640.5438
 f 800.578.5438
 e userlink@rotarylif.com

World Wide Contact Information

World Headquarters/USA: 1.812.273.1622
 Canada: 1.905.812.9920
 European Headquarters/Germany: +49.771.9233.0
 United Kingdom: +44.178.747.7711
 Australasia: +60.3.7660.0285
 Latin America / Caribbean: +54.3488.431.608
 Middle East / Northern Africa: +49.771.9233.0



A DOVER COMPANY

