



SL210/SL212

(500 Series)

SL210 Fixed Pad Capacity 9,000 lbs. and 10,000 lbs.

SL210 Capacity 10,000 lbs.

SL212 Capacity 12,000 lbs.

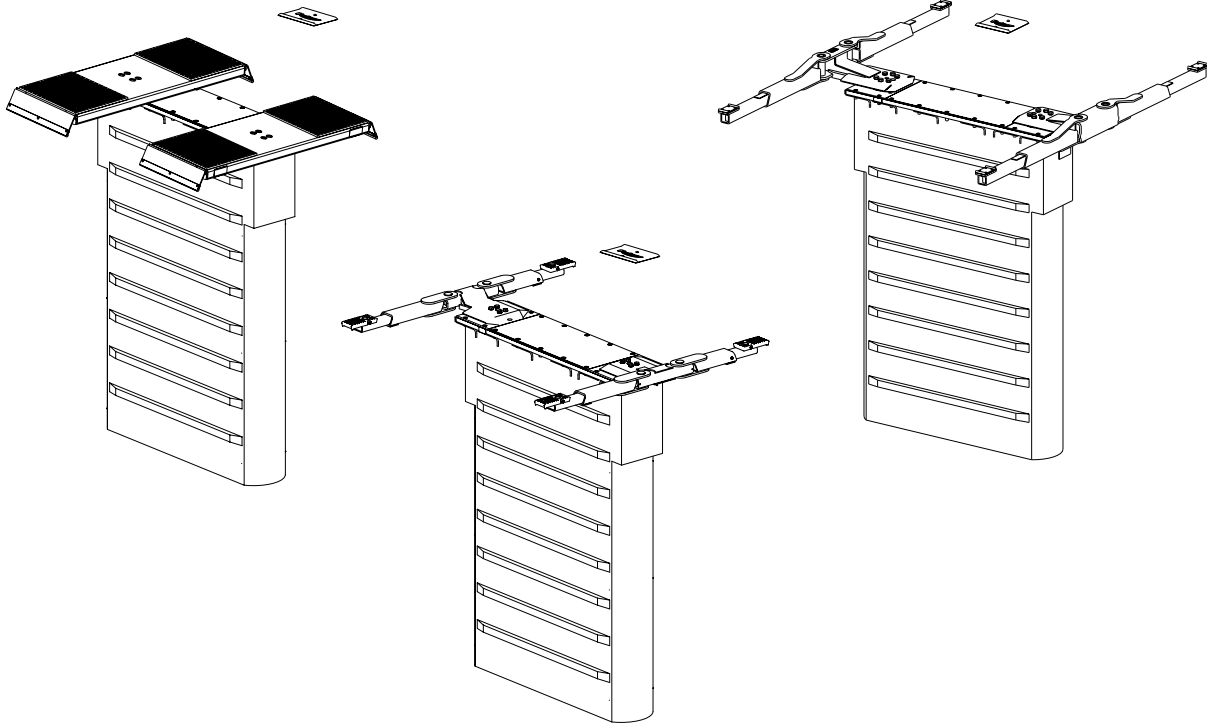

These Instructions Contain General Data. Any Deviation From Customers Prints Or Specifications Should Be Clarified Before Proceeding With Lift Installation.

IMPORTANT

Check the containment tube for holes due to shipping damage. Do not install a damaged containment tube. Contact Rotary Lift Customer Service. If the lift has a chance to be exposed to the elements, **protect the lift.**

LP20174

For Lifts With Welded Grade Angle:

IMPORTANT

Failure To Comply Will Void Warranty

Grade Angle

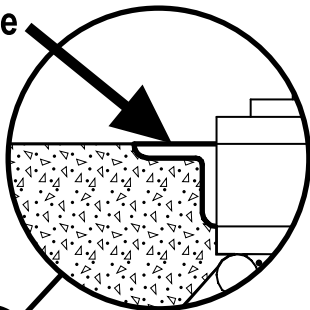

Concrete MUST BE
Finished To Grade Angle,
NOT The Top Of The Lift

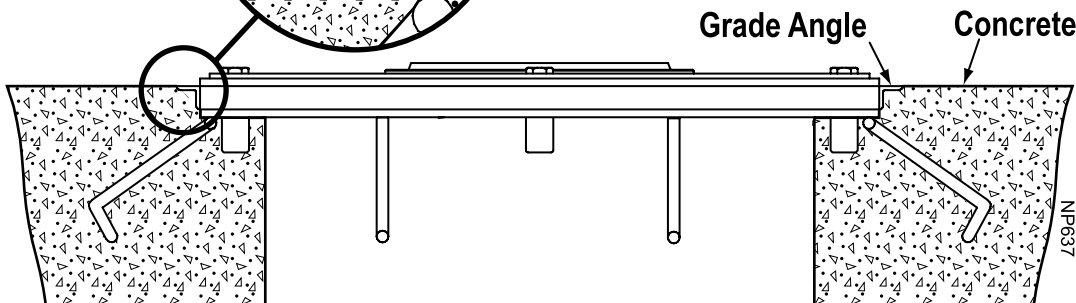

**Owner: Your Installer Is Responsible For
The Concrete Floor Being Finished To
Grade Angle, NOT To The Top Of The Lift.
Failure To Comply Will Void Warranty**

IMPORTANT

Contact with the electrical heating coils could cause electrolysis and damage the lift and/or its components. Make sure the lift frame concrete anchors do not contact electrical heating coils, or re-bar that may be in contact with other embedded electrical sources. The lift being physically connected to any source which promotes electrolysis will void the warranty.

For Lifts With Formed Grade Angle:

IMPORTANT

Failure To Comply Will Void Warranty

Edge Of
Grade
Indicator

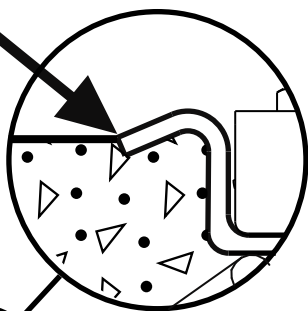

Concrete **MUST BE** Finished To
Edge Of Grade Indicator, **NOT**
The Top Of The Lift. Finished
Floor Level Must Be 1/4" Below
Top Of Lift On All Sides.

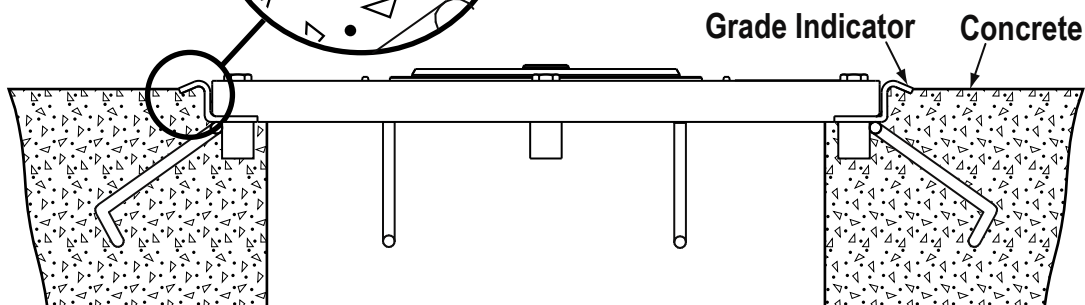

**Owner: Your Installer Is Responsible For
The Concrete Floor Being Finished To
Grade Angle, NOT To The Top Of The Lift.
Failure To Comply Will Void Warranty**

IMPORTANT Contact with the electrical heating coils could cause electrolysis and damage the lift and/or its components. Make sure the lift frame concrete anchors do not contact electrical heating coils, or re-bar that may be in contact with other embedded electrical sources. The lift being physically connected to any source which promotes electrolysis will void the warranty.

INSTALLATION INSTRUCTIONS

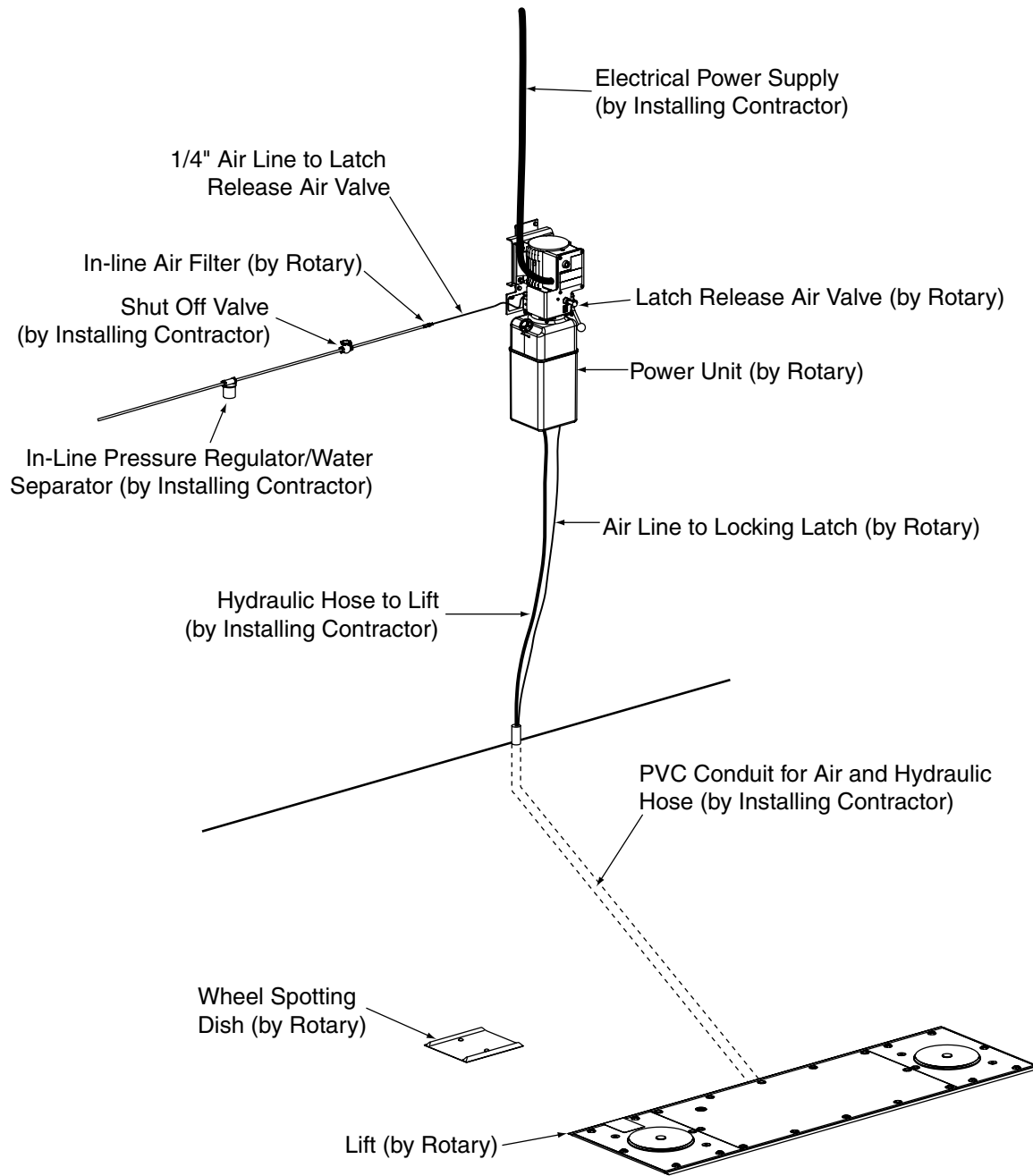

Please follow these instructions to ensure a good installation and satisfactory operation of the lift. Check your shipment against the product load list and shipping papers. Enter claims for damage or shortage with the delivering carrier at once.

- After installation, please return this booklet to the literature package and give to lift owner/operator.
- Literature package should be kept attached to power unit for easy access.
- Review entire installation instructions before beginning excavation.

IMPORTANT

The center cover is designed for foot traffic only.

WARNING

Restrict all unauthorized persons from going near excavation. OSHA standard restricts anyone from getting in excavated hole, unless OSHA guidelines are followed. See OSHA Excavating Standard CFR 1926.

Keep excavated hole covered and barricaded when installation is not in progress.

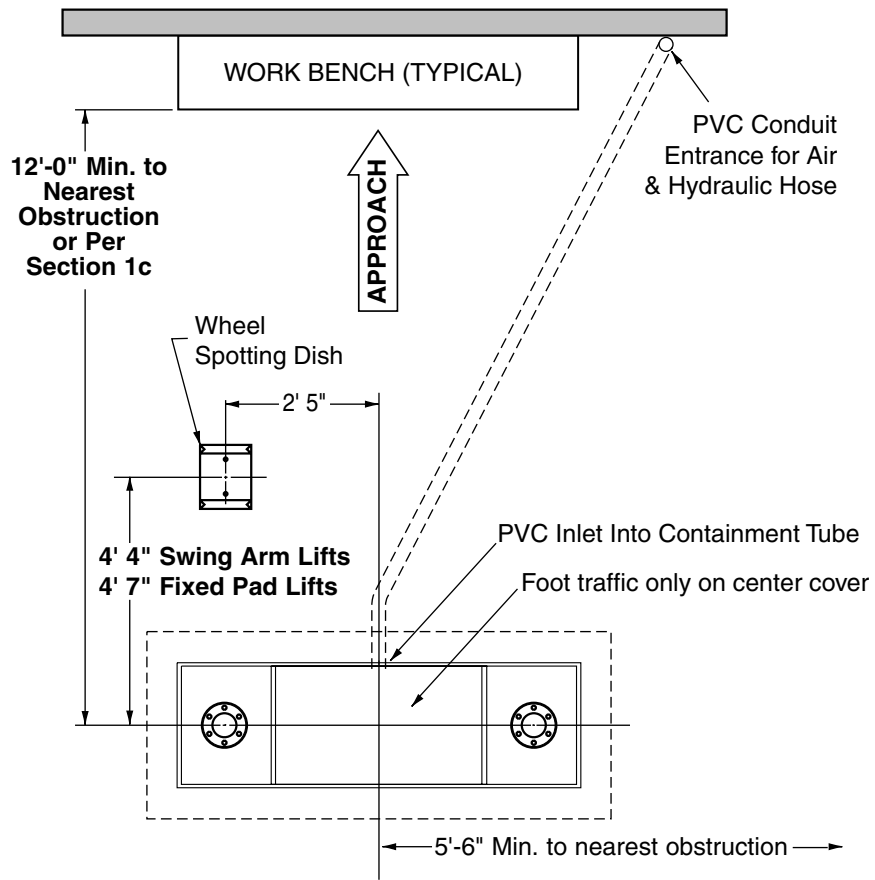

SL210 Series

Fig. 1

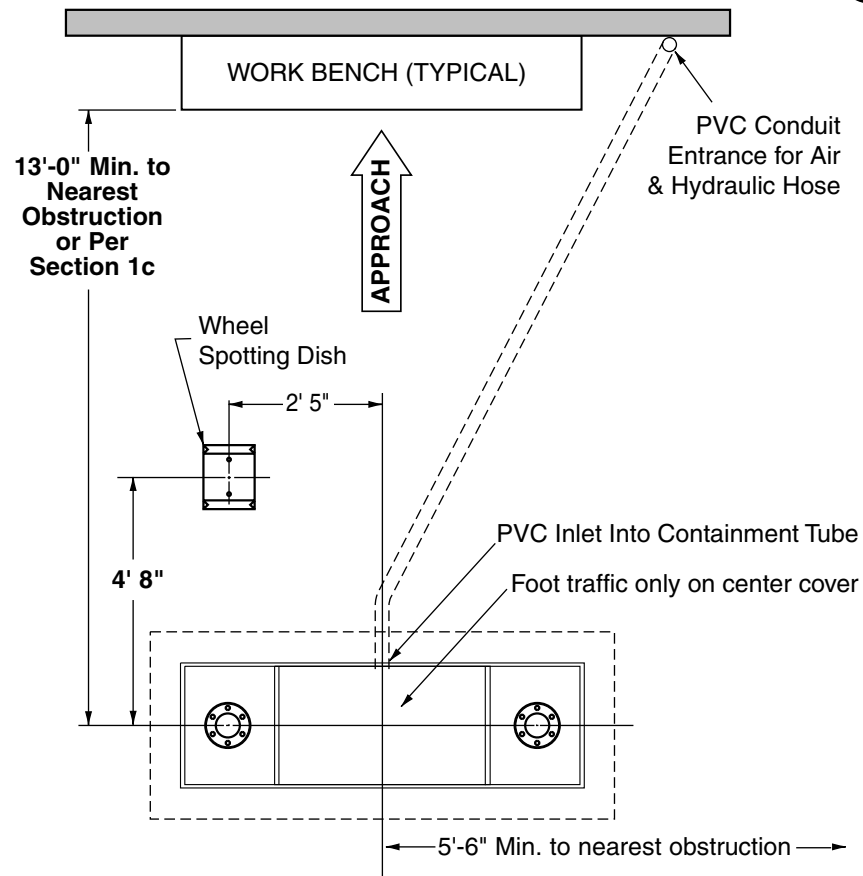

SL212 Series

1. Lift Location:

A. Check architect's layout if available. Lay out lift as shown in Fig. 1. Recommended floor slope is 1/16" per foot.

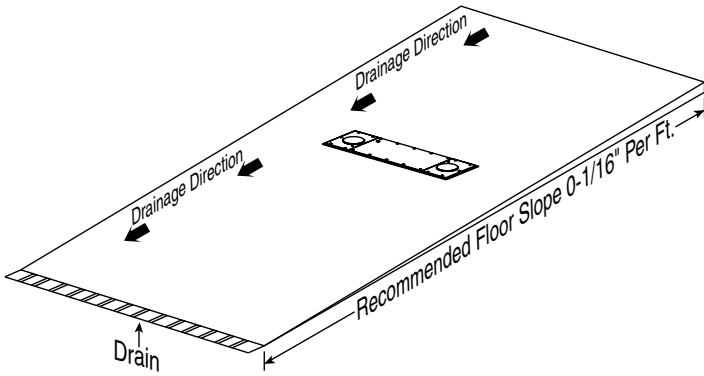

B. **SL210:** The 5' 6" centerline to side and 12' 0" centerline to front and rear dimensions should be maintained to provide adequate working space. The minimum overhead clearance should be 85" plus height of highest vehicle to be raised. 24' 0" length bay recommended. Other lengths may be used, provided ample clearance is maintained at each end of lift.

SL212: The 5' 6" centerline to side and 13' 0" centerline to front and rear dimensions should be maintained to provide adequate working space. The minimum overhead clearance should be 88" plus height of highest vehicle to be raised. 26' 0" length bay recommended. Other lengths may be used, provided ample clearance is maintained at each end of lift.

C. **Base Unit Lifts:** If you are planning to install roll-on/wheel alignment runways, locate lift per instructions from superstructure manufacturer. Use superstructure manufacturer's instructions for fore and aft, side to side, and ceiling clearances.

2. **Excavation:** Excavate hole to dimensions shown in Fig. 2. Dig trench for 2" PVC pipe between lift and power unit location. Trench should be dug 11" below finished floor grade. Air line and hydraulic hose to be contained in this 2" PVC pipe.

3. Concrete Preparation:

A. Run 2" PVC from Control Area to Containment Tube. PVC will enter the Containment Tube 9-1/2" below finished floor grade. Hole is centered horizontally in Containment Tube, Fig. 1.

B. **Box out a 5' x 10' area around where lift is to be located.** **NOTE: For multiple lift installations, boxed out areas will overlap. Dig continuous trench, see illustration below.**

C. Pour concrete floor ensuring not to get concrete in boxed out area.

NOTE: By using this installation method, the RAI can more accurately set lift to proper grade relative to finished floor. Reference Page 2.

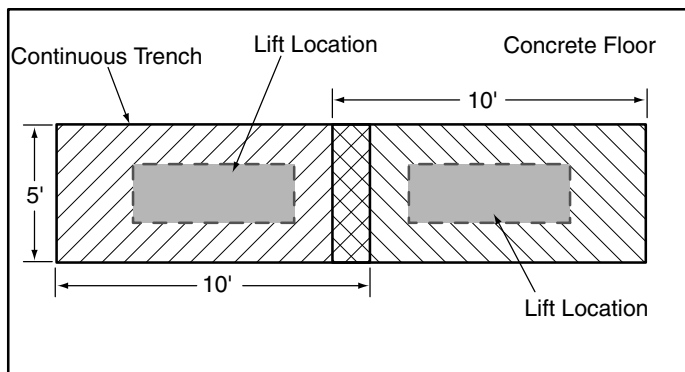

4. Lift Setting:

IMPORTANT Check the containment tube for holes due to shipping damage. Do not install a damaged containment tube. Contact Rotary Lift Customer Service.

A. Chain hoist must have capacity of 2,500 lbs. with a clear swing of 9' 0". Rig sling for unit, attaching to the shipping strap, Fig. 3, and lower assembly into hole. Center lift and be sure lift containment inlet is located as shown in Fig. 1.

IMPORTANT Owner: Your Installer Is Responsible For The Concrete Floor Being Finished To The Leading Edge Of The Grade Angle (1/4" Below Top Of Lift), NOT To The Top Of The Lift, Fig. 5. Failure To Comply Will Void Warranty.

B. Bend frame anchors out perpendicular to concrete frame and downward approximately 45° to floor level, Fig. 2.

C. Remove and retain (4) 1/2"-13NC HHCS (marked with X, Fig. 3). Insert 1/2" Threaded Rods x 18" lg. into the holes and secure in place using 1/2" flat washers and nuts, Fig. 4.

D. Attach 6 x 6's to support unit on existing floor and secure in place with 1/2" flat washers and nuts, Fig. 4. Remove shipping straps and install guide barrel bolts in open holes and torque to 60 ft-lbs. Remove protective covers from top of jacks.

NOTE: Make sure rubber thread protectors are still in place on all nuts welded to the concrete frame, including where the hardware was just added, Fig. 5. Note: that rubber thread protectors are not required if concrete frame has 1" blind nuts.

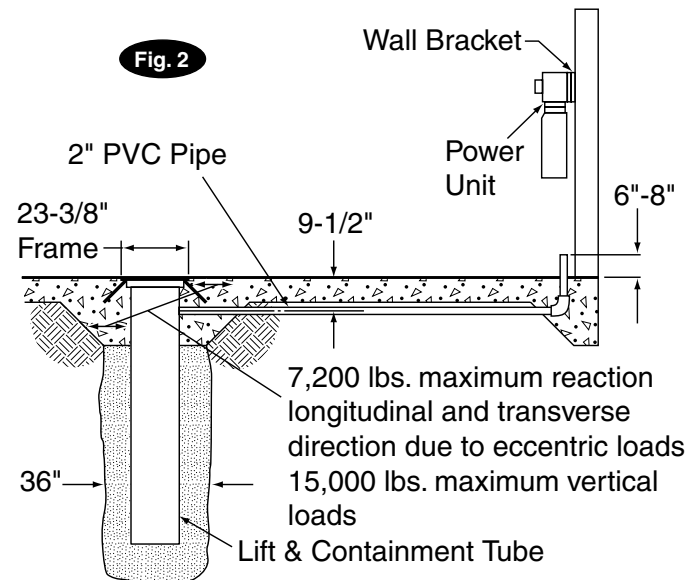
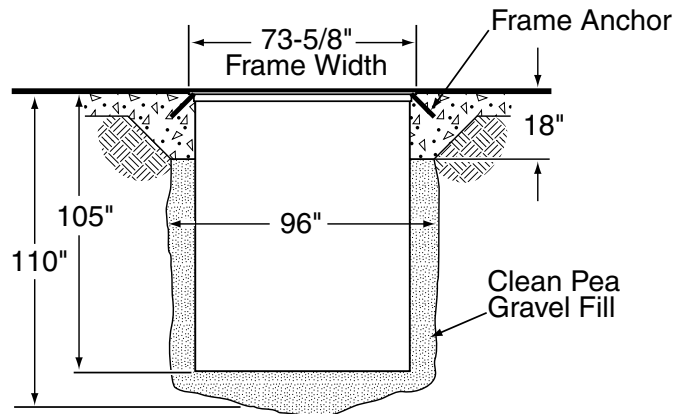

- E. Plumb and level by placing machinist level on top of jack. Do Not plumb or level off unit frame. See Fig 5.
- F. Shore Lift Securely!
- G. Connect 2" PVC to containment tube, chamfer PVC entering containment tube seal and lubricate I.D. of seal with grease or oil to ease entry of PVC into seal. PVC pipe should extend into containment tube 1" maximum.

NOTE: If your PVC pipe and containment inlet do not align, you may have to cut back PVC pipe, and attach 2" Flexible PVC to make connection. All PVC joints MUST be leak proof.

- H. Recheck plumb.

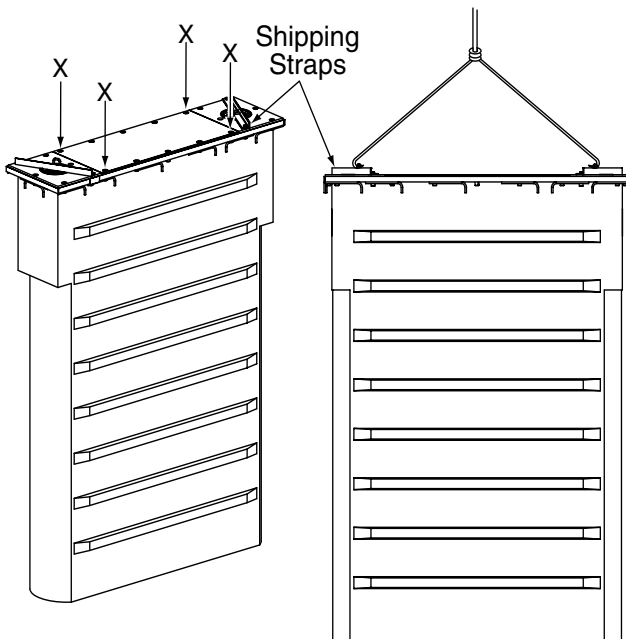

Fig. 3

5. Backfill:

- A. Duct tape joint areas indicated by X, Fig. 6, to protect these areas during backfill and concrete work. Backfill around unit using only pea gravel to within 18" of top of finished floor.

IMPORTANT Make sure thread protectors (supplied by Rotary) are on the underneath side of the concrete frame on all the bolts in the guide barrel and cover, Fig. 5. Note that thread protectors are not required if concrete frame has 1" diameter blind nuts.

CAUTION Do not use a mechanical tamper or saturate the backfill material to achieve compaction. This could cause lift containment sides to bend inward, **HAND TAMP ONLY**.

IMPORTANT Do Not fill plunger with any ballast material.

- B. Complete backfill and tamp pipe trench.
- C. After lift is backfilled, make final elevation and plumb checks, Fig 5.
- D. Make sure frame anchors are bent out, Fig. 7.

6. Concrete Work:

- A. Leave 6 x 6's in place.
- B. New concrete around the lift must be keyed into existing floor with rebar or stud anchors, Fig. 7.

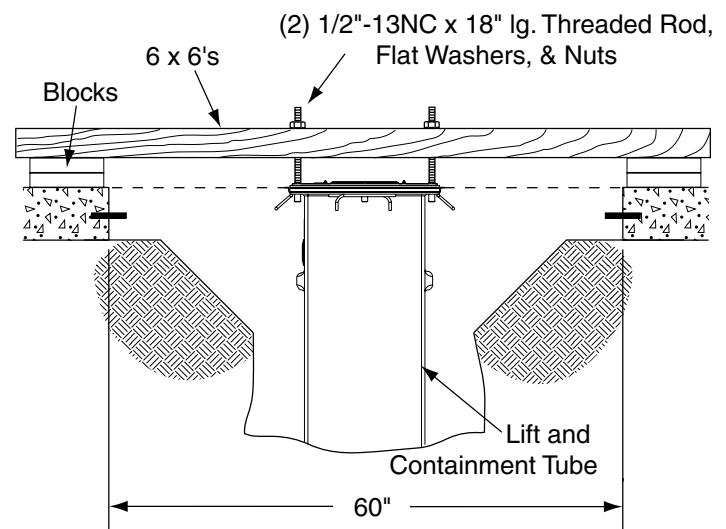
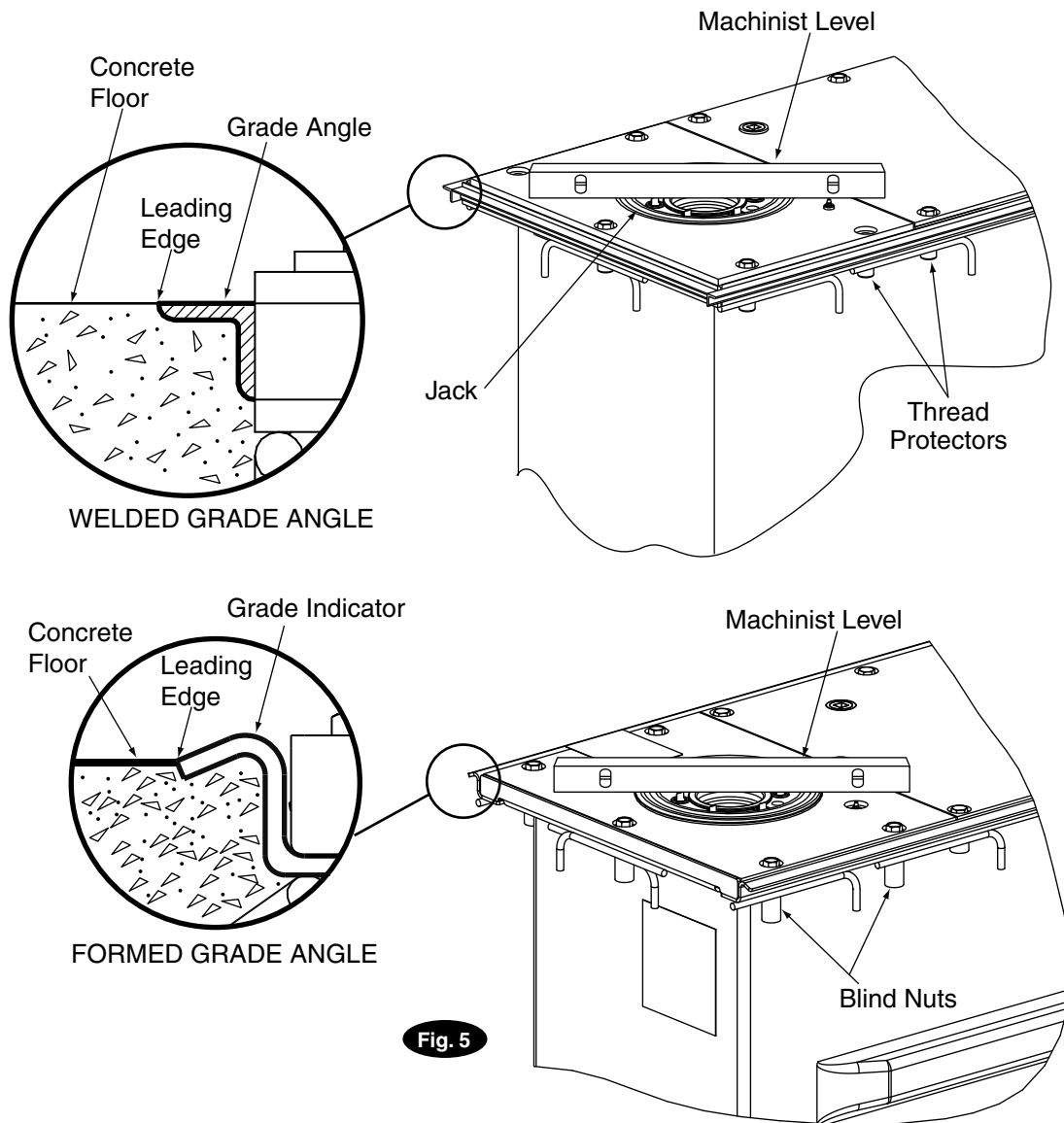

Fig. 4



C. A minimum concrete strength of 3,000 PSI is suggested. DO NOT use calcium chloride as a curing accelerator. If using a curing accelerator, we recommend a non-chloride additive such as High Early* or equivalent.

D. Pour concrete floor, being careful not to run concrete in and around top surface of lift unit.

IMPORTANT Owner: Your Installer Is Responsible For The Concrete Floor Being Finished To The Leading Edge Of The Grade Angle (1/4" Below Top Of Lift), NOT To The Top Of The Lift, Fig. 7. Failure To Comply Will Void Warranty.

IMPORTANT It is imperative that lift be set level regardless of floor slope or other factors. Trowel smooth and allow to harden.

E. After concrete is set-up, remove 6 x 6's and threaded rods.

F. Reinstall the guide barrel bolts, use Loctite 242 (blue) on bolts and torque to 60 ft.-lbs.

G. Do not use lift until concrete has achieved 3,000 PSI.

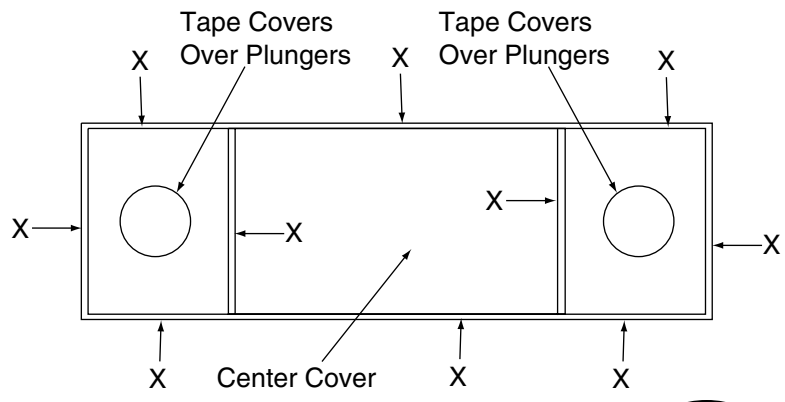

Fig. 6

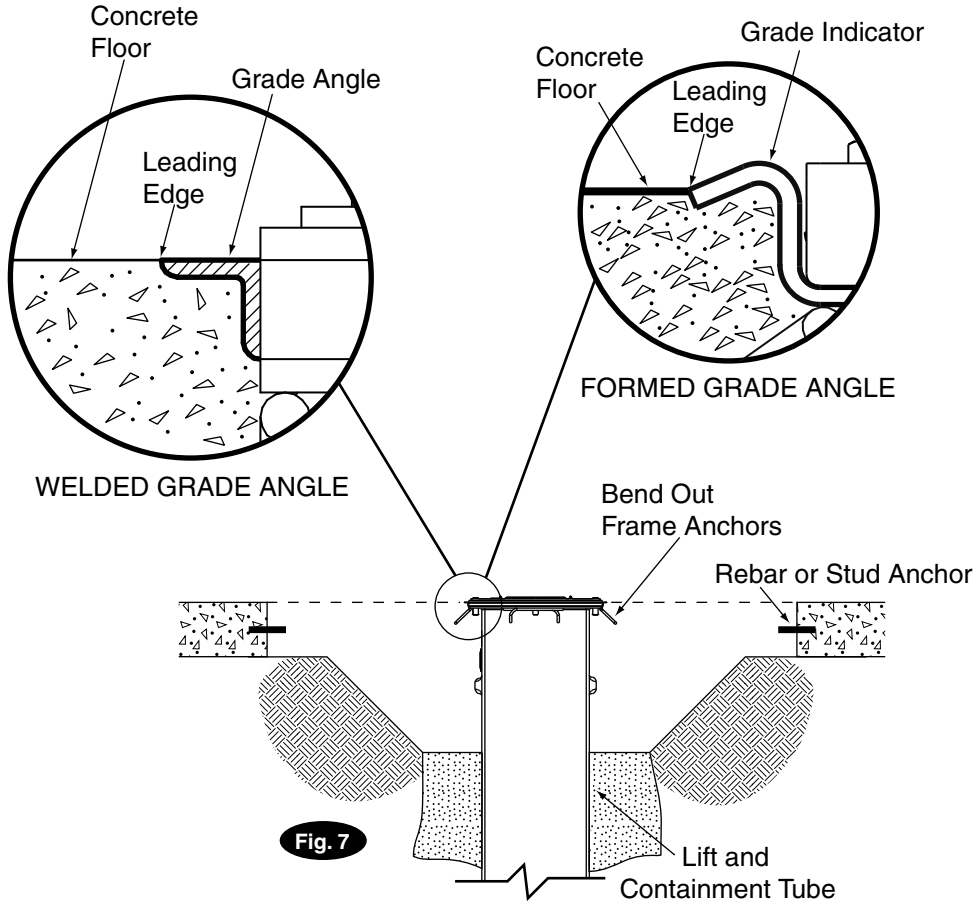

Fig. 7

*High Early is a registered trademark of General Portland Cement Company.

7. Power Unit:

A. For operating convenience, locate Power Unit mounting bracket so top of Motor will be approximately 56" above floor, Fig. 2.

B. Locate and mount the wall bracket, using (4) 3/8" wall anchors, on the wall. Anchors must be able to hold 20 lbs. of shear force.

C. Put (2) 5/16"-18NC x 1-1/2" HHCS through holes in the air valve bracket then through wall bracket, if rear mounted air valve bracket is supplied, using push-nuts to hold in place, Fig. 8. Put the other (2) 5/16"-18NC x 1-1/2" HHCS through wall bracket using push-nuts to hold in place, Fig. 8.

D. Mount power unit, with motor up, to the wall bracket and install (4) 5/16" nuts and lock washers, Fig. 8.

E. Install and hand tighten elbow adapter to pump until O-ring is seated, Fig. 11. Continue to tighten the locknut to 10-15 ft.-lbs., or until the nut and washer bottom out against the pump manifold. **NOTE:** You may still be able to rotate the Branch Tee. This is acceptable unless there is seepage at the O-ring. If so, slightly tighten the locknut.

CAUTION Over tightening locknut may tear O-ring or distort threads in pump manifold outlet.

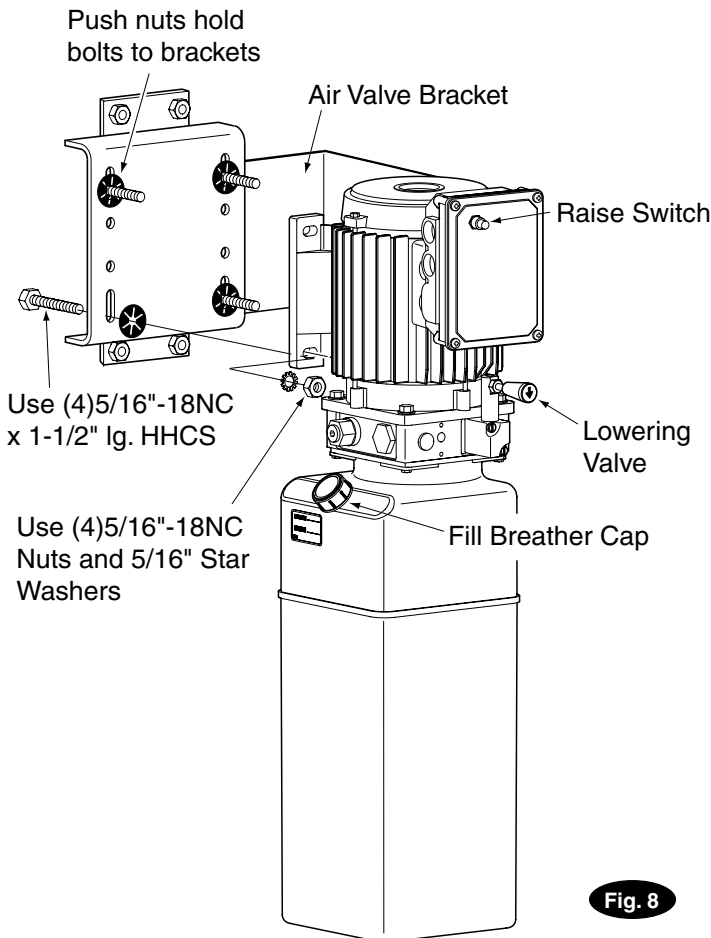

8. Electrical: Have a certified electrician run appropriate power supply to motor, Fig. 9 & 10. Size wire for 20 amp circuit. See Motor Operating Data Table.

CAUTION Never operate the motor on line voltage less than 208V. Motor damage may occur.

IMPORTANT: Use separate circuit for each power unit. Protect each circuit with time delay fuse or circuit breaker. For single phase 208-230V, use 20 amp fuse. Three phase 208-240V, use 20 amp fuse. For three phase 400V and above, use 10 amp fuse. For wiring see Fig. 9 & 10. All wiring must comply with NEC and all local electrical codes.

Note: 60Hz. single phase motor **CAN NOT** be run on 50Hz. line without a physical change in the motor.

MOTOR OPERATING DATA TABLE - SINGLE PHASE	
LINE VOLTAGE	RUNNING MOTOR VOLTAGE RANGE
208-230V 50Hz.	197-253V
208-230V 60Hz.	197-253V

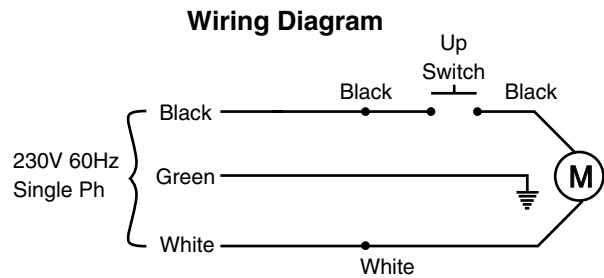
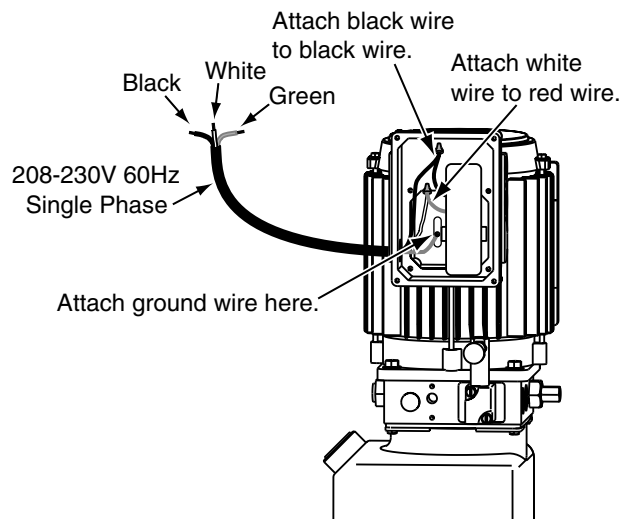

Fig. 9



NOTE: Two Different Drum Switches were used please select one of the two options below.

NOTES:

1. Unit not suitable for use in unusual conditions. Contact Rotary for moisture and dust environment duty unit.
2. Control Box must be field mounted to power unit.
3. Motor rotation is counter clockwise from top of motor.

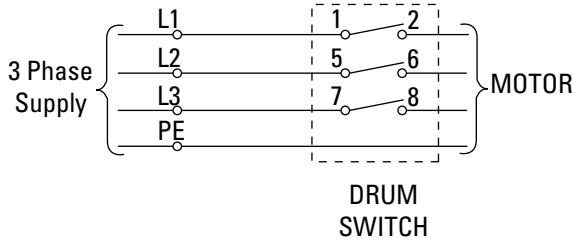

FOR 3 Ø POWER
 UNITS: Attach Box using
 M5 x 10 PHMS, Plated

**Capacitor Box Attachment
 Option One**

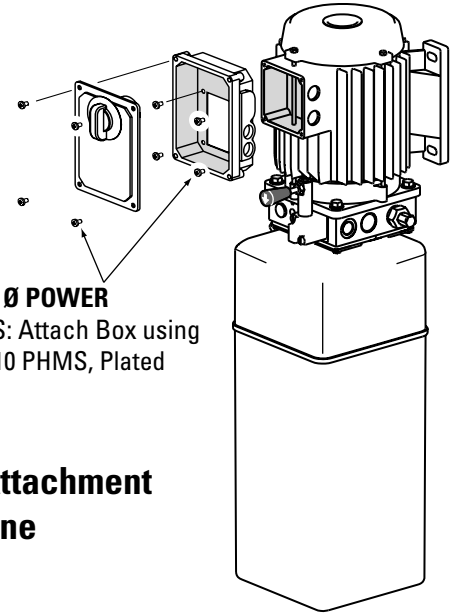
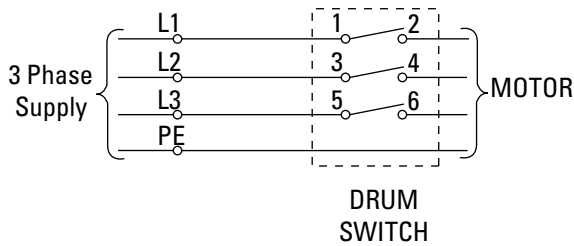
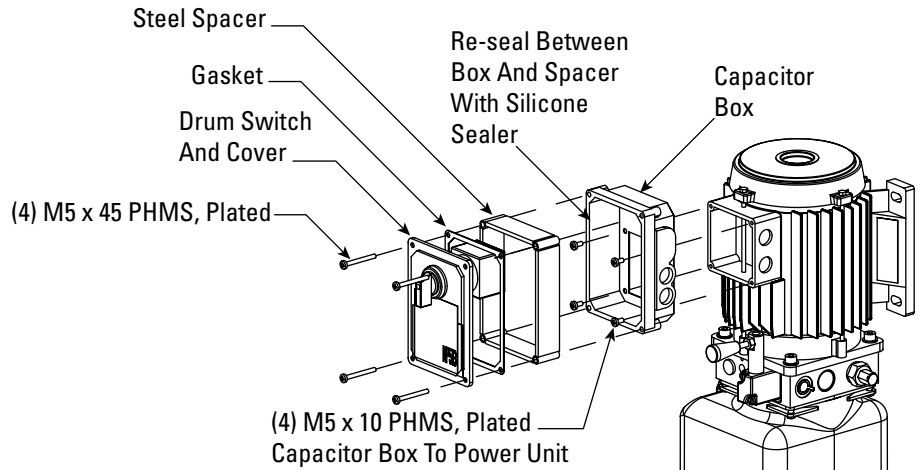
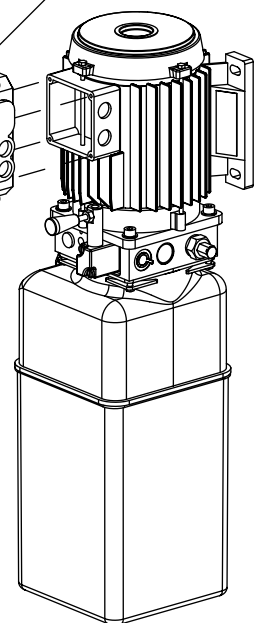

Fig. 10



**Capacitor Box Attachment
 Option Two**



MOTOR OPERATING DATA TABLE - THREE PHASE	
LINE VOLTAGE	RUNNING MOTOR VOLTAGE RANGE
208-240V 50/60Hz.	197-253V
400V 50Hz.	360-440V
440-480V 50/60Hz.	396V-528V
575V 60Hz.	518V-632V

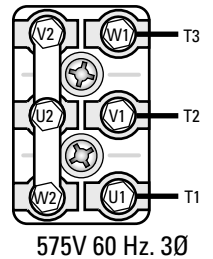
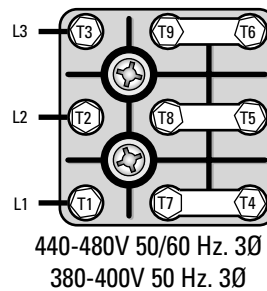
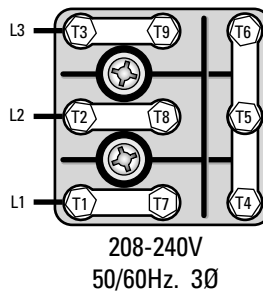

9. Supply Lines (By Installer): Remove center cover.

A. Hose:

1. Hose must meet Dayco EZ Flex 150 or equivalent specs. with 3,000 PSI minimum working pressure, 3/8" I.D. with 9/16-18THD, JIC fitting, female swivel ends.
2. Hose must be free of debris. Inspect all threads for damage, Fig. 11.
3. Push the hose through the 2" PVC pipe chase from power unit to lift unit.
4. Install hose onto elbow adapter on power unit and to hydraulic fitting in lift containment inlet.

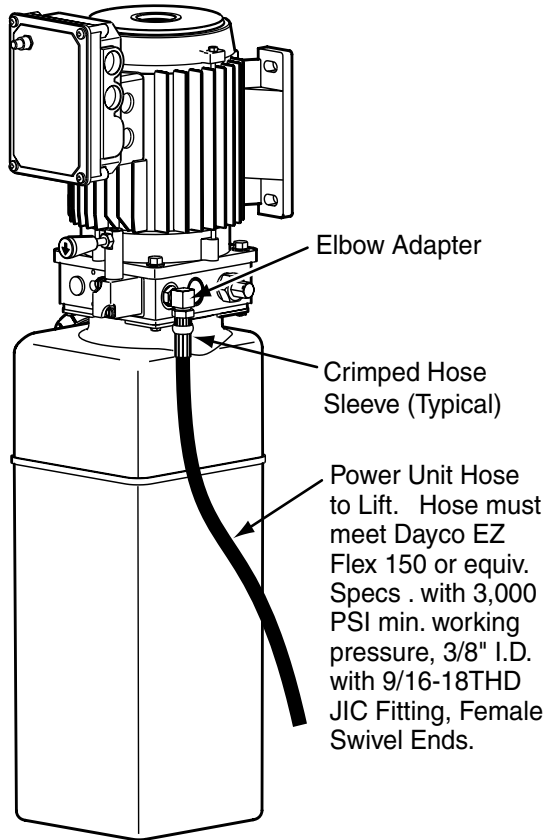

Fig. 11

Flared Fittings Tightening Procedure

1. Screw the fittings together finger tight. Then, using the proper size wrench, rotate the fitting 2-1/2 hex flats.
2. Back the fitting off one full turn.
3. Again tighten the fittings finger tight; then using a wrench, rotate the fitting 2-1/2 hex flats. This will complete the tightening procedure and develop a pressure tight seal.

B. Air Line:

IMPORTANT Shop air supply pressure must be between 90 to 120 psi.

1. Attach brass filter and swivel elbows to air latch, Figs. 12a and 12b.
2. Install latch release air valve to bracket, Figs. 12a and 12b.
3. Motor cover mounted air valve bracket: Mount air lock valve bracket over the power unit cover using the existing cover screws if single phase. If three phase use included longer screws.
4. Connect shop air supply with factory supplied in-line filter to latch release air valve 1/4" push-in 1/4" NPT fitting, Fig. 12 & Fig. 13.

5. Air line to the lift must be 1/4" polypropylene tubing with a 300 PSI working pressure.
6. Push air line tubing through the 2" PVC pipe chase from latch release air valve to lift unit.
7. Connect air line tubing to latch release air valve and to air line attached to vertical hose using push union, in lift containment inlet. Place decal on bracket, Figs. 12 & 13.

10. Fluid Filling:

A. System capacity is 19 quarts. Use Dexron III ATF, or Hydraulic Fluid that meets ISO 32 specification.

B. Remove fill-breather cap, Fig. 8.

C. Pour in 8 quarts of fluid.

D. Bleed lift by cycling to full rise several times.

E. Fully lower lift.

IMPORTANT

Lift must be fully lowered before changing or adding fluid.

F. Add fluid to power unit until it reaches the **MIN** _____ mark on the tank.

G. Replace fill-breather cap.

CAUTION

If fill-breather cap is lost or broken, order a replacement. DO NOT substitute with a solid plug.

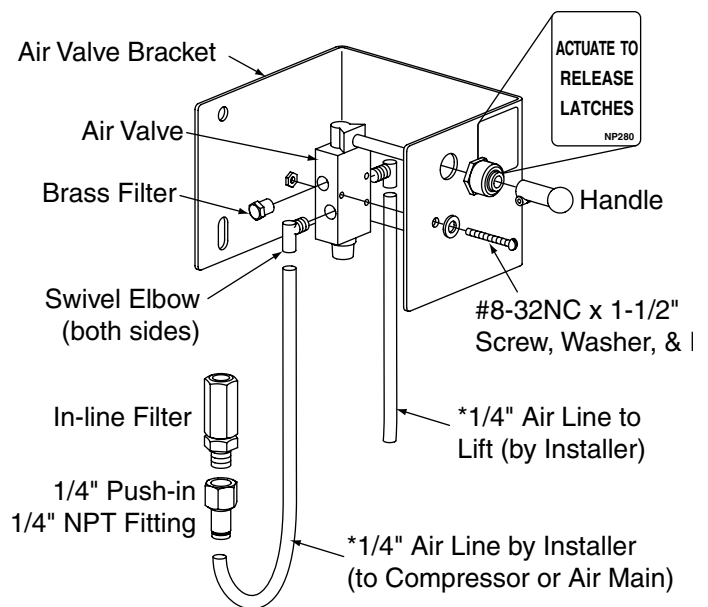

*Polyethylene Tubing 300PSI Minimum Working Pressure

Fig. 12a

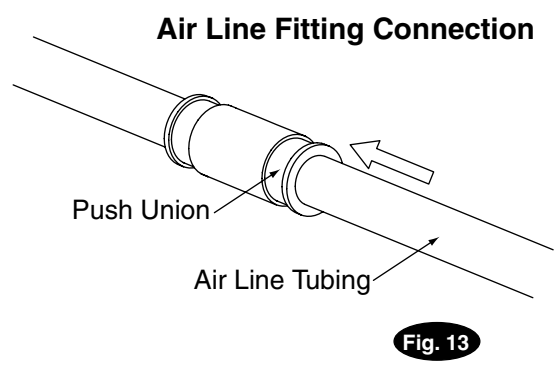
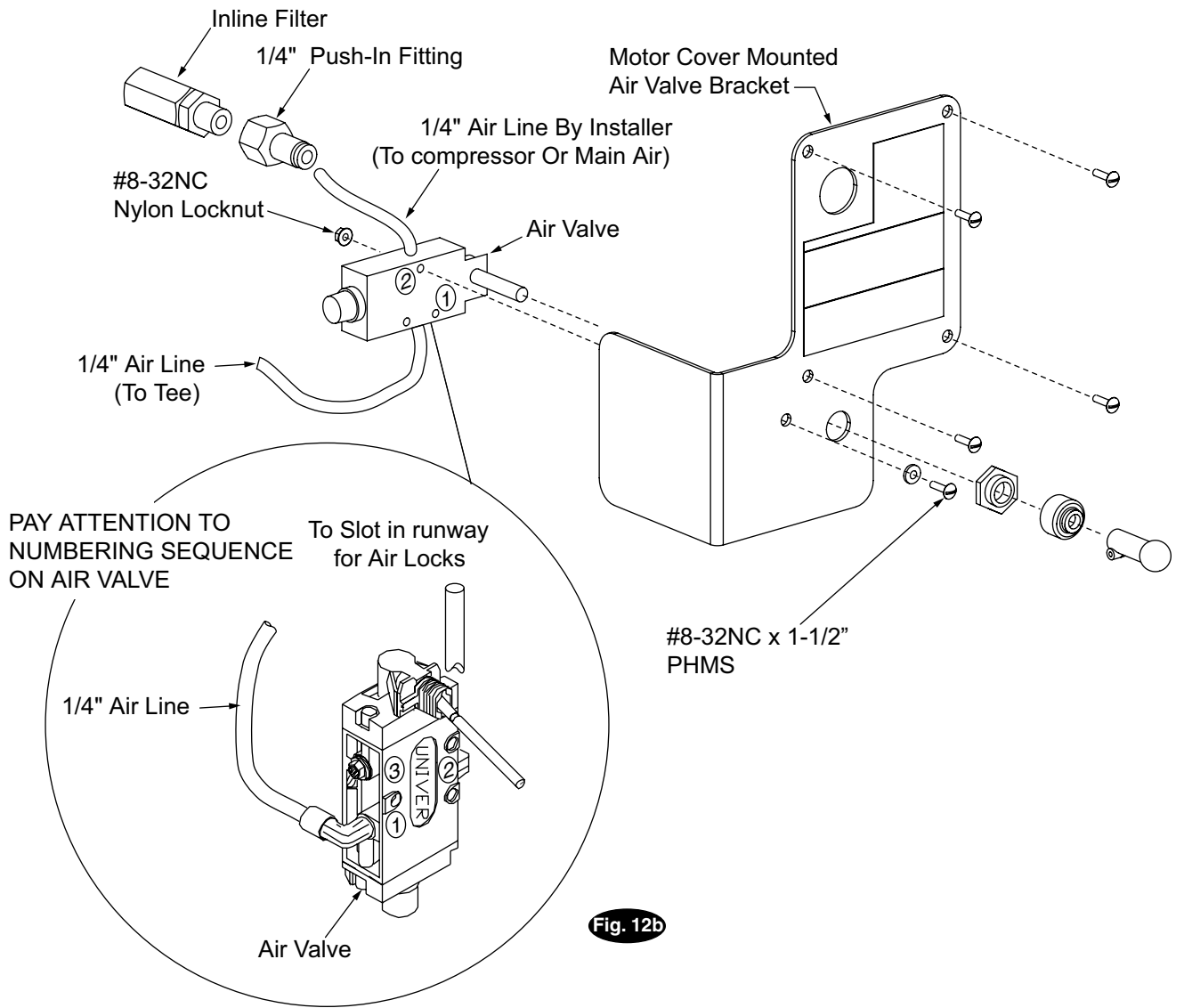

11. PRESSURE TEST:

- A. Run lift to full rise and keep motor running for 5 seconds.
- B. Stop and check all hose connections.
- C. Tighten or reseal if required. Repeat cycling of lift if adjustment was made.

11. LOCKING LATCH TEST:

- A. With lift in up position, actuate latch release air valve.
- B. Make sure latch engages and releases.

12. CYLINDER/LOAD PAD TEST:

- A. Raise lift to full rise and lower onto locks.
- B. Look into the containment tube to check that the high pressure cylinder rod is in the load pad hole, Fig. 14.

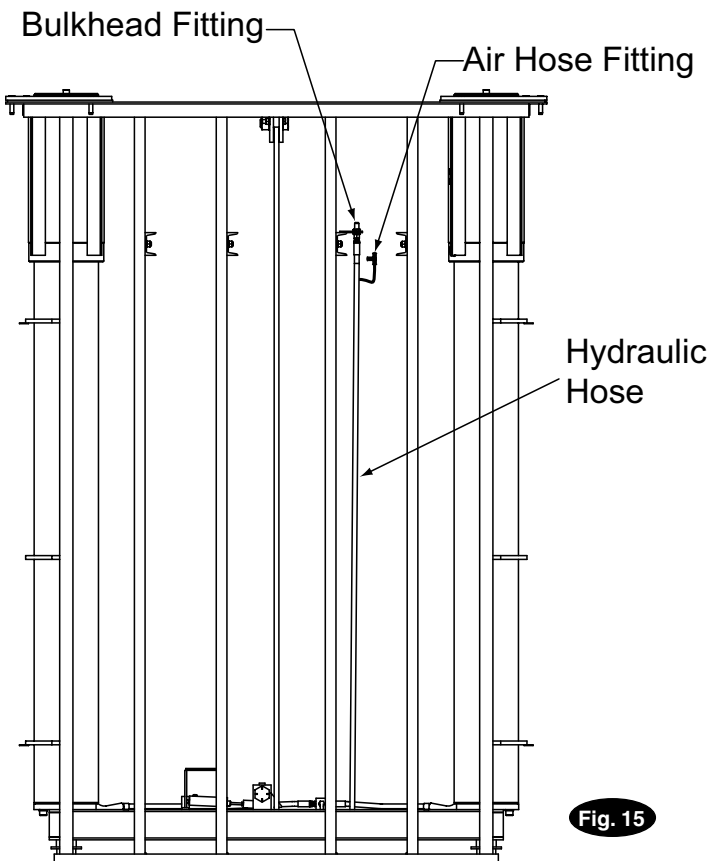
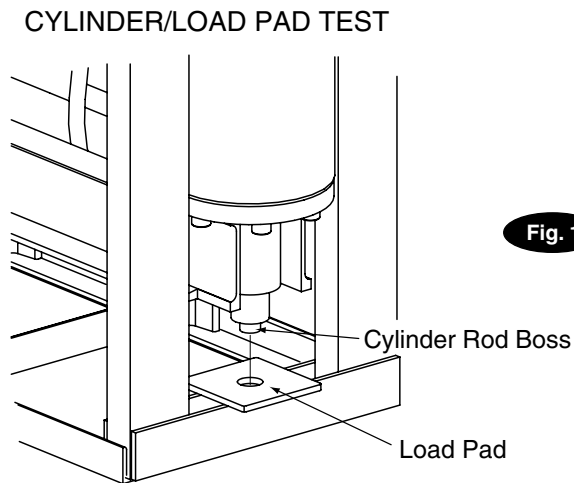

- C. Use a non-metal object (do not scratch or scar the cylinder rods), try to move the cylinder rod. If it does not move skip step D.
- D. Move the cylinder rod around until its boss goes back into the load pad center hole.

13. HOSE TRACKING TEST:

- A. Have someone raise the lift while another watches the tracking of the hose between the frame bulkhead and equalizer beam, Fig. 15. If the hose does not track between the members of the equalizer beam without rubbing, adjustment is necessary.

- B. Rotate the bulkhead fitting to adjust the position of the hose. Make sure that the bulkhead nut is tight after adjustment.

14. Setting Cover; refer to Fig. 16:

- A. Insert cover seal into lip in opening, making sure all holes align.
 - B. Install center cover onto seal.
 - C. Install and tighten cover retaining bolts. Torque to 60 ft-lbs.
- IMPORTANT** Clean areas indicated with X, Fig. 16, and seal with a premium 25 year silicone.

15. Superstructure:

SL210 Series:

- A. Base Unit Lifts: Install roll-on/wheel alignment runway per instructions from superstructure manufacturer.
- B. Swing Arm Superstructures: **Note arm locations, Fig. 17.**
 - 1. Install yokes to plungers with 7/8"-10NC x 3-1/2" HHCS and lock washer. Torque to 150 ft-lbs, Fig. 18.
 - 2. Grease swivel arm pins and arm holes with Lithium grease.
 - 3. Install (4) arm assemblies using the arm pins and snap rings.

Note arm locations, Fig. 17.

C. Fixed Pad Assemblies:

- 1. Install pads on lift using 7/8"-10NC x 3-1/2" HHCS and 3/4" external tooth lockwasher and torque to 150 ft.-lbs, Fig.19.

SL212 series:

- A. Base Unit Lifts: Install roll-on/wheel alignment runway per instructions from superstructure manufacturer.
- B. Swing Arm Superstructures:
 - 1. Install yokes to plungers with 7/8"-9NC x 3-1/2" HHCS and lock washer. Torque to 150 ft-lbs., Fig. 20.
 - 2. Grease swivel arm pins and arm holes with Lithium grease.
 - 3. Install (4) arm assemblies using the arm pins and cotter pins, Fig. 21.

16. Final Touches:

- A. Lag wheel spotting dish to floor using two 3/8" anchors provided. Verify model number of lift being installed and refer to Fig. 1 for respective dimensions.
- B. Raise lift and clean sand and dirt from plunger and lift area.
- C. Double check to make sure the guide barrel and center cover are sealed per Step 14.

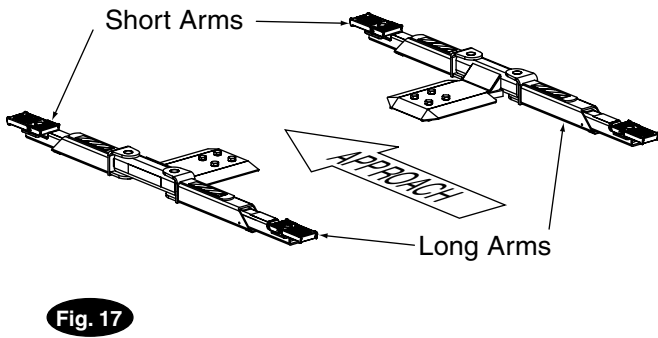
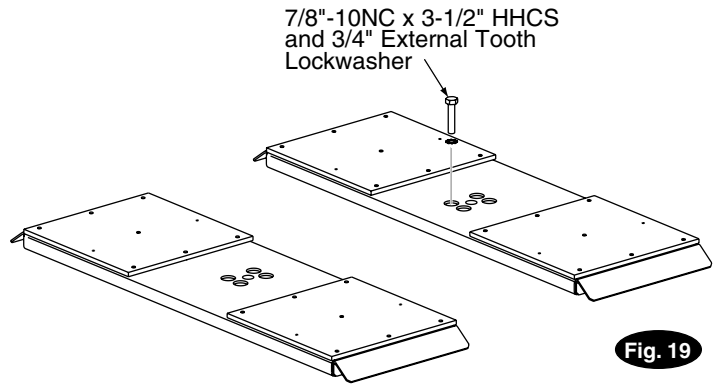
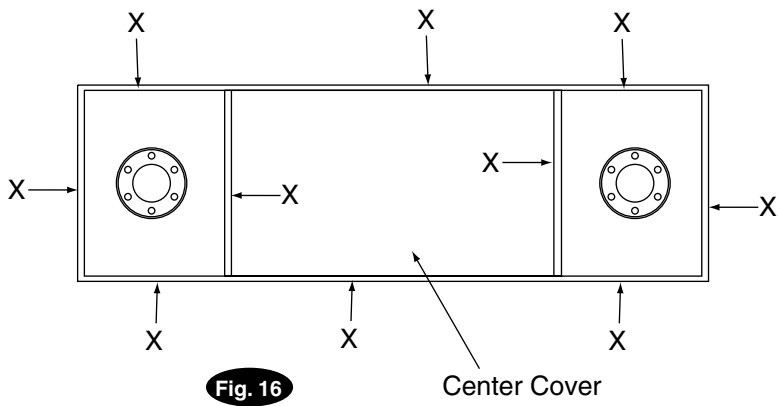

Please note locations of long and short arms in relation to approach. N/A for lifts with (4) short arms.

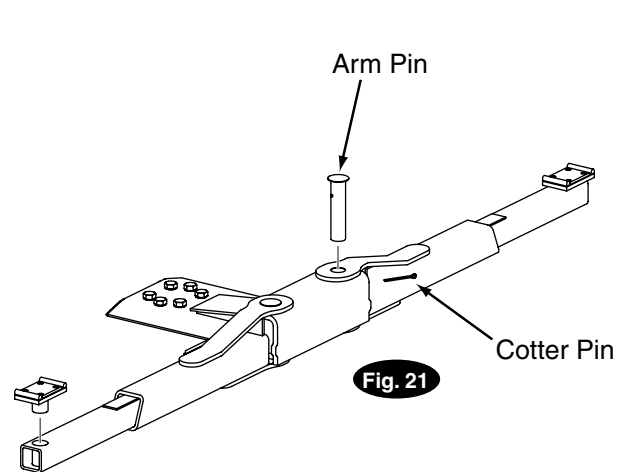
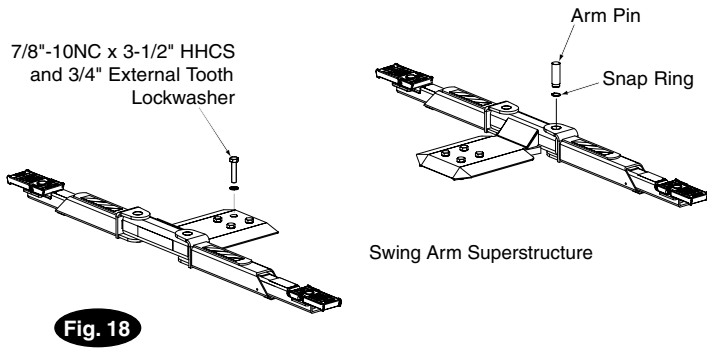
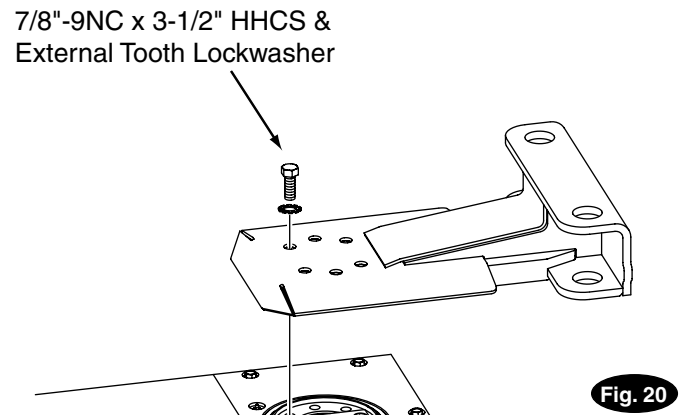

Installer: Please return this booklet to literature package, and give to lift owner/operator.

Thank You

Trained Operators and Regular Maintenance Ensures Satisfactory Performance of Your Rotary Lift.

Contact Your Nearest Authorized Rotary Parts Distributor for Genuine Rotary Replacement Parts. See Literature Package for Parts Breakdown.

Revision	Date	Change(s) Made
--	09/11/03	New 500 Series lift.
A	06/07/04	Add new wiring diagrams, remove writing/storage shelf and add fixed pad capacity to title page.
B	01/05/06	Updated air line details.
C	01/05/07	Added Formed Angle Graphics
D	09/27/07	Updated drum switch wiring.

Rotary World Headquarters

2700 Lanier Drive
Madison, IN 47250, USA
www.rotarylif.com

North America Contact Information

Tech. Support: p 800.445.5438
f 800.578.5438
e userlink@rotarylif.com
Sales: p 800.640.5438
f 800.578.5438
e userlink@rotarylif.com

World Wide Contact Information

World Headquarters/USA: 1.812.273.1622
Canada: 1.905.812.9920
European Headquarters/Germany: +49.771.9233.0
United Kingdom: +44.178.747.7711
Australasia: +60.3.7660.0285
Latin America / Caribbean: +54.3488.431.608
Middle East / Northern Africa: +49.771.9233.0



A DOVER COMPANY

