



SL210/SL210i  
SL210U  
SL212/SL212i  
(800 Series)

SL210/SL210i/SL210U Moveable Pad Capacity 8,000 lbs.

SL210/SL210i/SL210U Capacity 10,000 lbs.

SL212/SL212i Capacity 12,000 lbs.

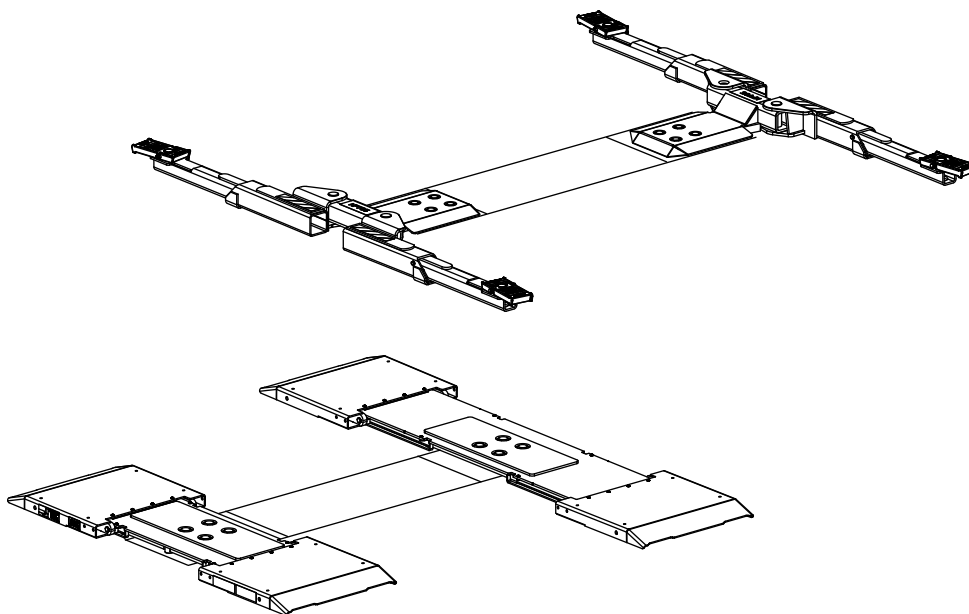

**Table Of Contents**

<b>Owner/Employer Responsibilities</b>	<b>2</b>
<b>Safety Instructions</b>	<b>3</b>
<b>Operating Instructions (SL210/SL210i/SL212/SL212i Swing Arm)</b>	<b>4</b>
<b>Moveable Pad Supplemental Operating Instructions</b>	<b>8</b>
<b>Approved Accessories</b>	<b>13</b>
<b>Maintenance Instructions</b>	<b>10</b>
<b>Trouble Shooting</b>	<b>11</b>
<b>Lift Lockout/Tagout Procedure</b>	<b>13</b>
<b>Operating Conditions</b>	<b>13</b>
<b>Manual Lowering of Lift</b>	<b>14</b>

**Installer:** Please return this booklet to literature package and give to lift owner/operator.

**LP20446 - LP20449 - LP20577**

OM20195  
Rev. B 12/8/2011

# OWNER/EMPLOYER RESPONSIBILITIES

## The Owner/Employer:



- Shall ensure that lift operators are qualified and that they are trained in the safe use and operation of the lift using the manufacturer's operating instructions; ALI/SM01-1, ALI Lifting it Right safety manual; ALI/ST-90 ALI Safety Tips card; ANSI/ALI ALOIM-2008, American National Standard for Automotive Lifts-Safety Requirements for Operation, Inspection and Maintenance; ALI/WL Series, ALI Uniform Warning Label Decals/Placards; and in the case of frame engaging lifts, ALI/LP-GUIDE, Vehicle Lifting Points/Quick Reference Guide for Frame Engaging Lifts.
- Shall establish procedures to periodically inspect the lift in accordance with the lift manufacturer's instructions or ANSI/ALI ALOIM-2008, American National Standard for Automotive Lifts-Safety Requirements for Operation, Inspection and Maintenance; and The Employer Shall ensure that lift inspectors are qualified and that they are adequately trained in the inspection of the lift.
- Shall establish procedures to periodically maintain the lift in accordance with the lift manufacturer's instructions or ANSI/ALI ALOIM-2008, American National Standard for Automotive Lifts-Safety Requirements for Operation, Inspection and Maintenance; and The Employer Shall ensure that lift maintenance personnel are qualified and that they are adequately trained in the maintenance of the lift.
- Shall maintain the periodic inspection and maintenance records recommended by the manufacturer or ANSI/ALI ALOIM-2008, American National Standard for Automotive Lifts-Safety Requirements for Operation, Inspection and Maintenance.
- Shall display the lift manufacturer's operating instructions; ALI/SM 93-1, ALI Lifting it Right safety manual; ALI/ST-90 ALI Safety Tips card; ANSI/ALI ALOIM-2008, American National Standard for Automotive Lifts-Safety Requirements for Operation, Inspection and Maintenance; and in the case of frame engaging lifts, ALI/LP-GUIDE, Vehicle Lifting Points/Quick Reference Guide for Frame Engaging Lifts; in a conspicuous location in the lift area convenient to the operator.
- Shall provide necessary lockout/tagout means for energy sources per ANSI Z244.1-1982 (R1993), Safety Requirements for the Lockout/Tagout of Energy Sources, before beginning any lift repairs.
- Shall not modify the lift in any manner without the prior written consent of the manufacturer.

# Safety Instructions

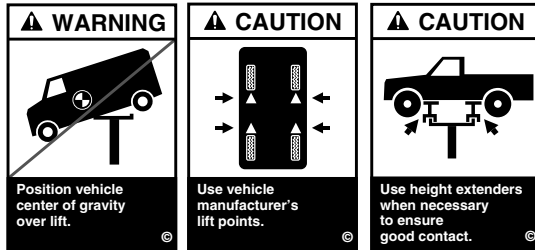

- **Daily** inspect your lift. Never operate if it malfunctions or if it has broken or damaged parts. Use only qualified lift service personnel and genuine Rotary parts to make repairs.
  - **Thoroughly** train all employees in use and care of lift, using manufacturer's instructions and "Lifting It Right" and "Safety Instructions" supplied with the lift.
  - **Never** allow unauthorized or untrained persons to position vehicle or operate lift.
  - **Prohibit** unauthorized persons from being in shop area while lift is in use.
  - **Do Not** permit anyone on lift or inside vehicle when it is either being raised or lowered.
  - **Always** keep area around lift free of tools, debris, grease and oil.
  - **Never** overload lift. Capacity of lift is shown on nameplate affixed to the lift.
  - **Do Not** stand in front of the lift or vehicle while it is being positioned in the lift bay.
  - **Do Not** hit or run over lift arms or adapters. This could damage lift or vehicle. Before driving vehicle into bay, position arms and adapters to provide unobstructed entrance onto lift.
  - **Always** use all four adapters when raising vehicle. **Never** use just two adapters to raise just one side or one end of the vehicle.
  - **Load** vehicle on lift carefully. Position lift adapters to contact the vehicle at vehicle manufacturer's recommended lift points.
- IMPORTANT** The center cover is designed for foot traffic only.
- CAUTION** If you are working under vehicle, lift should be raised high enough for locking latch to engage.
- **Always** use all four lift adapters when raising vehicle.
  - **Do Not** block open or override self-closing lift controls, they are designed to return to the Off or Neutral position when released.
  - **Remain** clear of lift and vehicle when lowering.
  - **Always** use safety stands when removing or installing heavy components.
  - **Avoid** excessive rocking of vehicle while on lift.
  - **Clear** area if vehicle is in danger of falling.
  - **Remove** tool trays, stands, etc. before lowering lift. Release locking latch before attempting to lower lift.
  - **Position** lift arms and adapters to provide an unobstructed exit before removing vehicle from lift area.
  - **Do Not** perform any maintenance on the power unit, control valves, air or fluid lines, hydraulic cylinders, or check fluid level until lift has been fully lowered and all pressure has been released from system. Follow OSHA Lockout/Tagout procedures as they apply; reference ANSI Z244.1.

# SL210/SL210i/SL212/SL212i/SL210U SWING ARM OPERATING INSTRUCTIONS

## ⚠️ WARNING

To avoid personal injury and/or property damage, permit only trained personnel to operate lift. After reviewing these instructions, get familiar with lift controls by running the lift through a few cycles before loading vehicle on lift.

## IMPORTANT

Always lift the vehicle using all four adapters. **NEVER** raise just one end, one corner, or one side of vehicle.

## ⚠️ WARNING

If Lift is not operating properly, **DO NOT** use until adjustments or repairs are made by a qualified lift service personnel.

### Observe and heed SAFETY, CAUTION, and WARNING labels on the lift.

1. Lift must be fully lowered and service bay clear of all personnel before the vehicle is brought on lift. Do not stand in the front of a moving vehicle.
2. Position lift arms and adapters to provide unobstructed entrance of vehicle onto lift.
3. **Spotting:** Spot vehicle on lift with left front wheel in proper spotting dish position, Fig. 1.
4. **inbay Lift Controls:** The lift controls are on the power unit, Fig. 2. The lift will cease to run when you stop pressing the buttons on the power unit.

**Conventional Lift Controls:** The Raise Button, Safety Latch Air Release, and Lowering Valve are designed to close when released, Fig. 2. **Do Not** block open or override self-closing feature.

5. **Loading:** Position arms and adapters at the vehicle manufacturer's recommended lift points. Use intermediate, high step or optional adapters/extensions for under-body clearance when required, Fig. 3 and Fig. 4.

## IMPORTANT

Adapter extensions are furnished in 4" and 8" increments for 12,000 lbs. capacity lifts and 3-1/2" and 5" for 10,000 lbs. capacity lifts. The stack height should not exceed 12" for 12,000 lbs capacity lifts or 8-1/2" for 10,000 lbs capacity lifts. Use adapter extension combinations to keep vehicle as level as possible while it is being supported by the lift.

## ⚠️ WARNING

Before attempting to lift pick-up trucks or other truck frame vehicles, be sure that:

- A. Vehicle individual axle weight does not exceed one-half lift capacity.
- B. Adapters are in secure contact with frame at vehicle manufacturer's recommended lift points, Fig. 3 and Fig. 4.
- C. Vehicle is stable on lift and neither "front" nor "tail" end heavy.
- D. Adequate overhead clearance is provided to raise vehicle to desired height.
- E. Rotate front and rear adapter to oppose each other when using the high step adapter and/or any auxiliary height extending adapter, Fig. 5.

**Note:** Allow 2 seconds between motor starts. Failure to comply may cause motor burnout.

### Typical Wheel Spotting Postions

#### Front Wheel Drive Vehicles

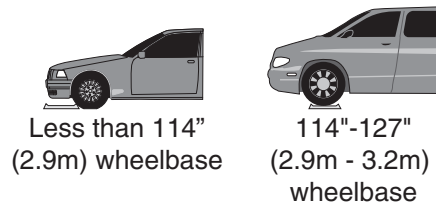
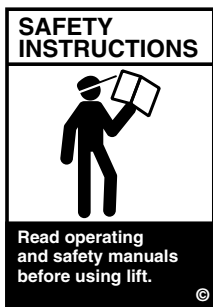
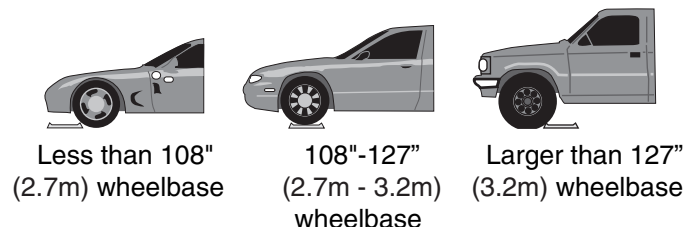

Fig. 1

#### Rear Wheel and 4 Wheel Drive Vehicles



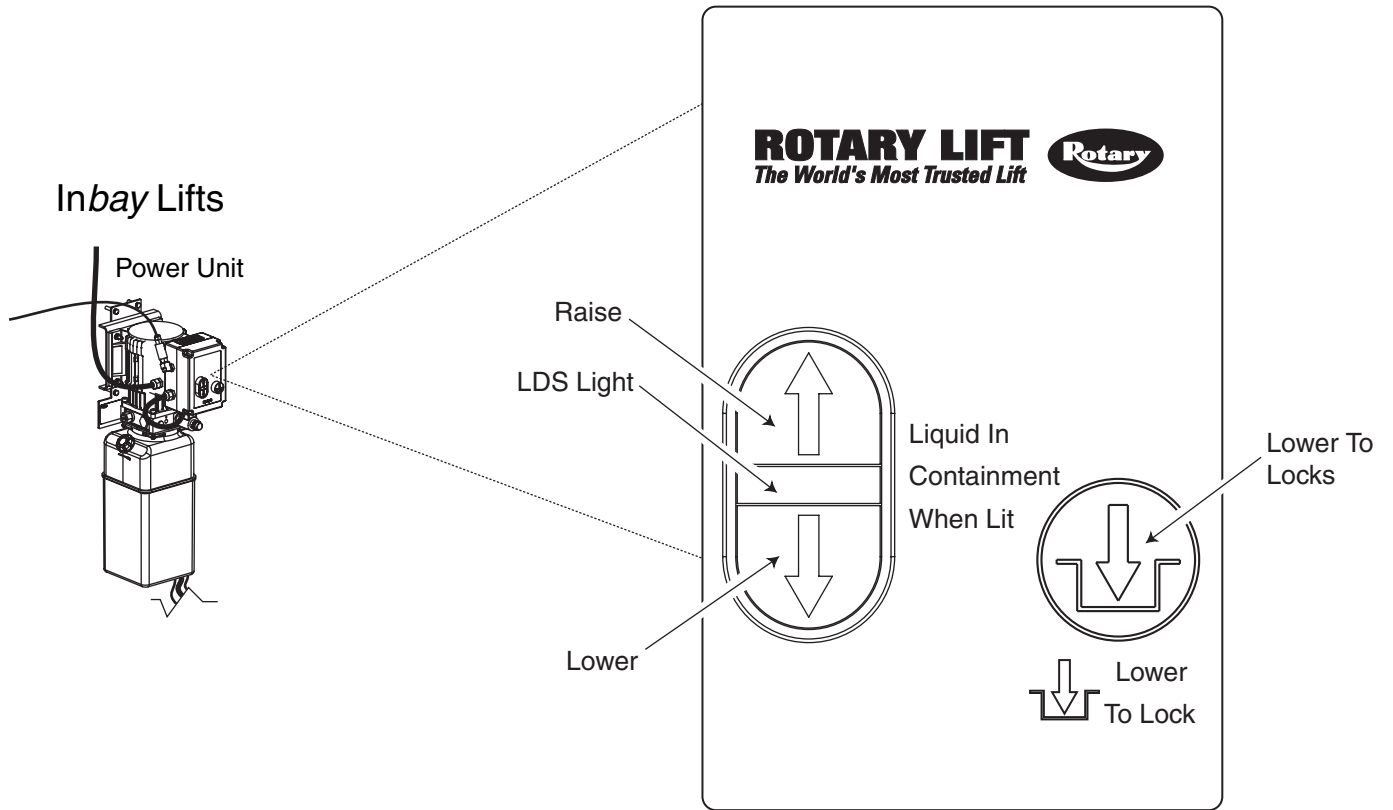
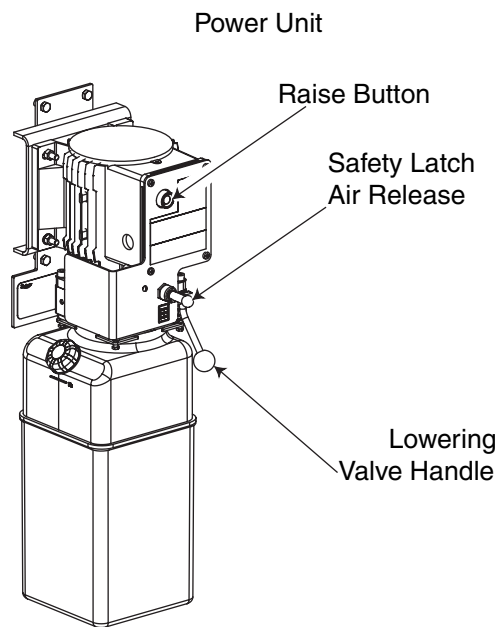

Fig. 2

### Conventional Lifts



# SL210/SL210i/SL212/SL212i SWING ARM OPERATING INSTRUCTIONS

## 6. To Raise Lift:

- Push RAISE button, Fig. 2. Raise lift until vehicle tires clear the floor.

**Check Adapter Contact:** Stop and check adapters/pads for secure contact at vehicle manufacturer's recommended lift points, Fig. 3 and Fig. 4. Shake car moderately at front or rear bumper.

**Check For Interferences:** Stop and check to make sure wheels and mudflaps clear lift arms/pads.

- Continue to raise vehicle to desired height, **only** if vehicle is secure on lift.
- Lower lift and repeat vehicle **spotting** and **loading** procedure if required.
- Locking latch should be heard when lift is being raised. If not heard, lower lift and check locking latch.
- Do Not go under vehicle unless all four adapters are in secure contact at vehicle manufacturer's recommended lift points and the locking latch is engaged.
- Lower lift to locking latches by pushing the lower to lock button for inbay units or holding down only the lowering valve handle for manual units, Fig. 2.

**CAUTION** Do not go under vehicle if locking latches are not engaged.

## 7. While Using Lift:

- Avoid excessive rocking of vehicle while on lift.
- Always use safety stands when removing or installing heavy components.

## 8. To Lower Lift:

- Remove all tools or other objects from lift area.
- Raise lift off locking latches by pushing the RAISE button, Fig. 2.
- inbay Lifts:** Press LOWER button to lower lift, Fig. 2.

**Conventional Lifts:** Actuate safety latch air release and hold until lift is fully lowered, Fig. 2. Push lowering valve handle to lower, Fig. 2.

**inbay Lift Note:** If LOWER button is released, the latch should reset to engaged position.

**Conventional Lift Note:** Both the Safety Latch Air Release and Lowering Valve Handle are deadman-type design. Each must be held down to lower lift. Do not override self-closing lift controls.

- Remain clear of lift and vehicle when lowering. Observe pinch point WARNING decals.
- Return adapters to lowest position and move arms and adapters to provide an unobstructed exit before removing vehicle from lift area.

**inbay Note:** If the lift is in a raised position and a power outage occurs, the lift may be lowered manually. Turn to Manual Lowering of Lift, page 17. If the service center lost electrical power, the lift will operate when power is restored.

- If lift is damaged or not operating properly, **Do Not** use until adjustment or repairs are made by qualified lift service personnel.

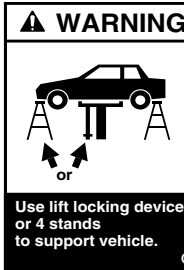
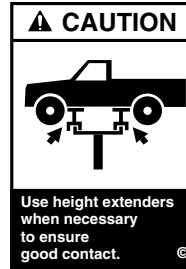
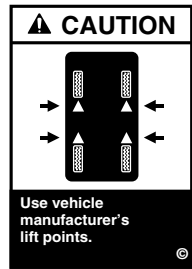
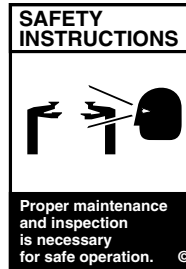

# SL210/SL210i/SL212/SL212i SWING ARM OPERATING INSTRUCTIONS

**NOTE:** Some vehicles may have the manufacturer's Service Garage Lift Point locations identified by triangle shape marks on it's undercarriage (reference ANSI/SAE J2184-1992). Also, there may be a label located on the right front door lock face showing specific vehicle lift points. If the specific vehicle lift points are not identified, refer to the "Typical Lift Points" illustrated herein. ALWAYS follow the operating instructions supplied with the lift.

**⚠️WARNING** Most specialty or modified vehicles cannot be raised on a frame engaging lift. Contact vehicle manufacturer for raising or jacking details.

## Typical Lifting Points

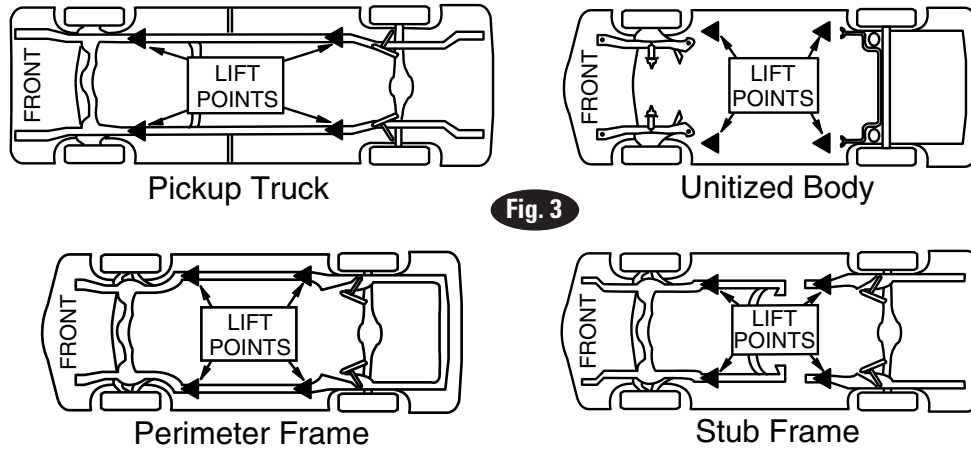
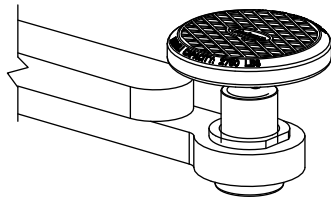
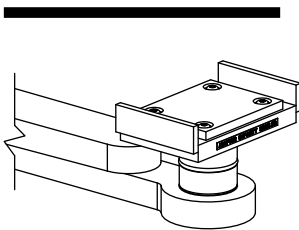

Fig. 3

### Three Stage Arm Adapters



This style adapter only for use on Unibody Vehicles.



This style adapter must be used when lifting Pickup Truck Frame, Stub Frame and Perimeter Frame Vehicles.

### Three Position Flip-up Adapter

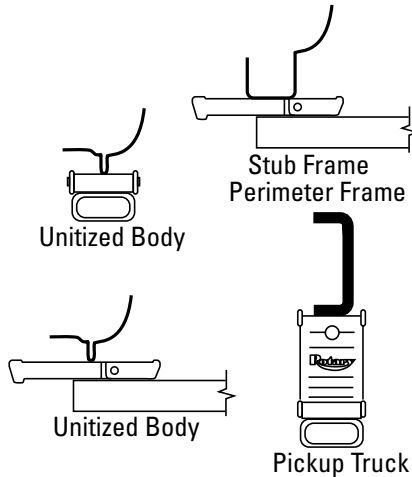

Fig. 4

### Adjustable Screw/Pad Adapter

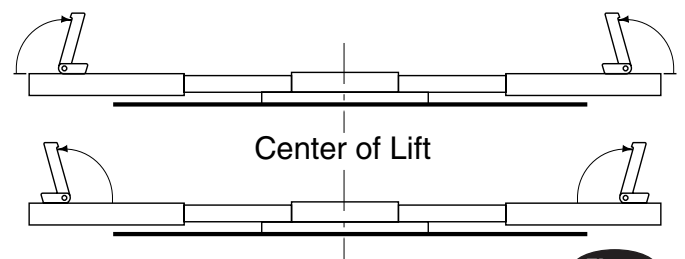
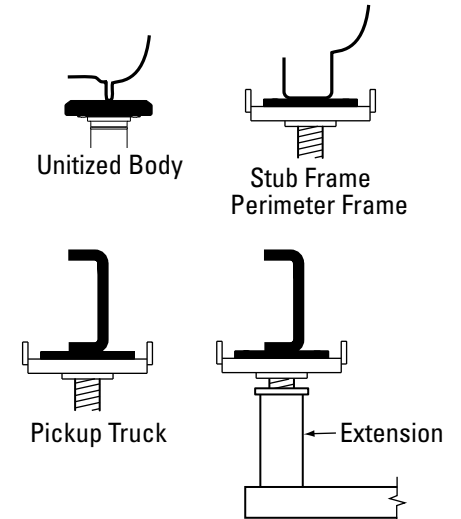

Fig. 5

# MOVEABLE PAD SUPPLEMENTAL OPERATING INSTRUCTIONS

## Spotting and Loading Vehicle on Lift:

- A. Assure lift is fully lowered and service bay clear of all personnel.
- B. Drive over superstructure and spot vehicle with left front wheel in proper spotting dish position as shown in Fig. 6.
- C. Adjust moveable portion of the moveable pad until it is located under the vehicle manufacturer's recommended pick-up points, Fig. 8.

**CAUTION** DO NOT raise limousines or pick-up trucks. DO NOT raise SUVs, vans, or other speciality vehicles not of a unibody construction, Fig. 8.

- D. Place auxiliary adapters on the moveable pad under the vehicle manufacturer's recommended pick-up points, Figs. 7 and 8, to ensure clearance between vehicle chassis and moveable pad.

**IMPORTANT** Always use auxiliary adapters under vehicle pick-up points.

**WARNING** DO NOT stack auxiliary adapters. Never set adapters on their side or end.

## Typical Wheel Spotting Postions

### Front Wheel Drive Vehicles

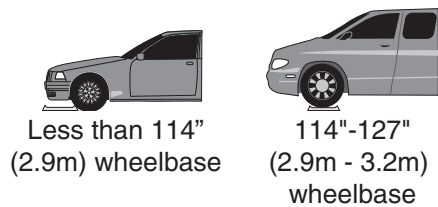

Fig. 6

### Rear Wheel and 4 Wheel Drive Vehicles

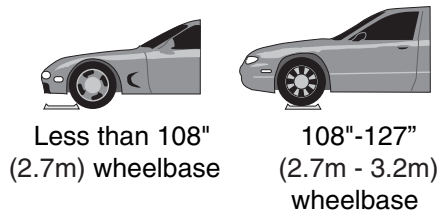
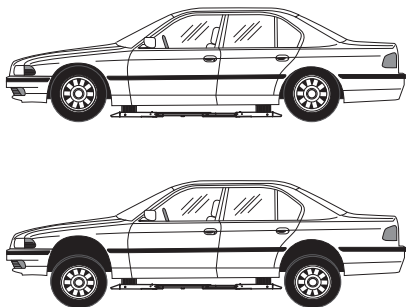
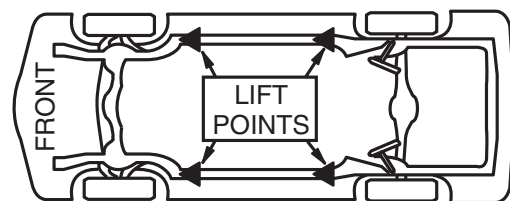

Fig. 7



## Typical Lifting Points



Perimeter Frame

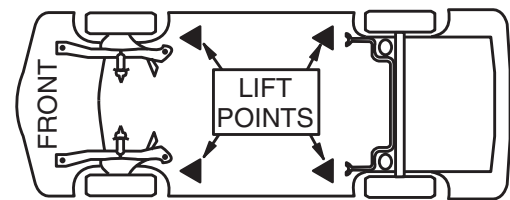

Unitized Body

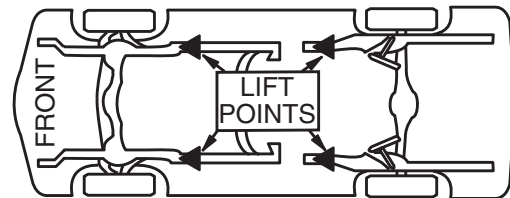

Stub Frame

Fig. 8

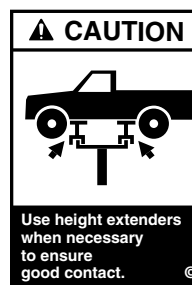
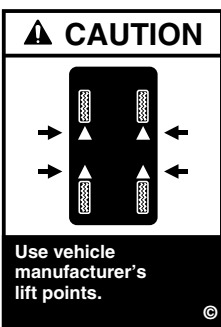



# MAINTENANCE INSTRUCTIONS

## ⚠️ WARNING

If you are not completely familiar with automotive lift maintenance procedures

**STOP.** Contact factory for instructions. To

avoid personal injury, permit only qualified personnel to perform maintenance on this equipment.

**Always** keep locking latch free and oiled.

**Always** keep all bolts tight.

**Always** keep superstructure clean. In salt belt or other corrosive environments, the lift must be washed down weekly.

**Always** make sure the perimeter of the guide barrel and center cover are sealed with a good grade of silicone.

**NOTE** Be sure plugs on superstructure's are in place.

**Daily** inspect adapters for damage or excessive wear. Replace as required with genuine Rotary parts.

**Daily** check locking latch operation.

If locking latch is not heard when lift is raised:

**A.** Lower loaded lift onto lock, to check if lock is functioning. If lock is functioning, stop. If not, continue on to "Step B".

**B.** Remove center cover and raise unloaded lift to full rise.

**C.** Check locking latch for damage or air line problem.

**D.** Repair and lubricate locking latch pivot points.

**E.** Lower lift about half way. Then raise lift and watch locking latch operation.

**F.** The air cylinder should allow locking latch to pivot in and out of the latch bar.

**G.** Push the toggle latch release switch on motor. This should retract air cylinder and locking latch from latch bar in-order to lower lift.

**H.** Replace center cover and torque bolts to 60 ft.-lbs.

**I.** Seal around the perimeter of the guide barrel and center cover with a good grade of silicone.

**Monthly** check containment for liquid accumulation. Remove if liquid is present.

**A.** Check for liquid by looking through inspection port on center cover. Replace plug in inspection port when complete. If your lift does not have an inspection port then:

**B.** Remove center cover. When complete replace center cover and torque bolts to 60 ft.-lbs. Seal around the perimeter of the guide barrel and center cover with a good grade of silicone.

**Monthly** lubricate lift guide barrels.

Guide Barrel Lubrication:

**A.** Each guide barrel has a grease fitting on the top of the guide barrel.

**B.** While raising and lowering unloaded lift, give each guide barrel 10-12 pumps with "hand" (manual) grease gun using only Genuine Rotary Grease.

**Every 3 Months:** Check plunger guide barrel bolts for tightness. Bolts should be torqued to 60ft.-lbs, Fig. 10.

**Semi-annually** check fluid level of lift power unit and re-fill if required per installation instructions using Dexron III ATF or ISOVG32 Hydraulic Fluid.

**Replace** all caution, warning or safety related decals on the lift if unable to read or missing. Reorder labels from Rotary Lift, see Safety Warning Labels for Inground Lifts.

**Replace** important decal on outside of yokes if unable to read or missing. Reorder labels from Rotary Lift.

## Safety Warning Labels for Inground Lifts

### Lift Owner/User Responsibilities:

- This Safety Warning placard, Fig. 10, SHALL be displayed in a conspicuous location in the lift area.
- Use one of the mounting arrangements illustrated on back of this placard.
- These Safety Warning labels supplement other documents supplied with the lift.
- Be certain all lift operators read and understand these labels, operating instructions and other safety related information supplied with the lift.

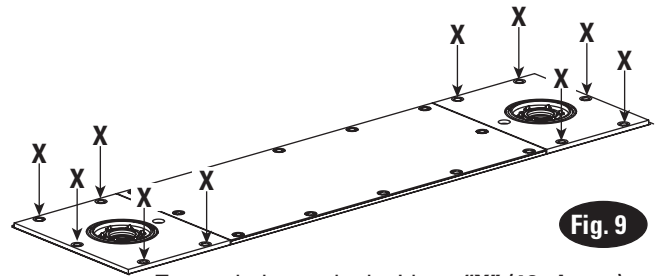

**Fig. 9**

Torque bolts marked with an "X" (10 places) to 60ft.-lbs. every 3 months.

TYPICAL PLACARD LOCATIONS				
<b>CAUTION</b>	<b>CAUTION</b>	<b>CAUTION</b>	<b>CAUTION</b>	<b>CAUTION</b>
<b>CAUTION</b>	<b>SAFETY INSTRUCTIONS</b>	<b>SAFETY INSTRUCTIONS</b>	<b>SAFETY INSTRUCTIONS</b>	
<small>The messages and pictures shown are generic in nature and are meant to generally indicate hazards common to all lifts regardless of specification. Funding for the development of these labels provided by the Autor Institute, PO Box 3311 FL 32903-3116. They are protected by Set of labels may be a AU or its member company. © 1992 by ALL Inc.</small>				

## SAFETY WARNING LABELS FOR INGROUND LIFTS

### Lift Owner/User Responsibilities:

**Fig. 10**

- This Safety Warning placard SHALL be displayed in a conspicuous location in the lift area.
- Use one of the mounting arrangements illustrated on back of this placard.
- These Safety Warning labels supplement other documents supplied with the lift.
- Be certain all lift operators read and understand these labels, operating instructions and other safety related information supplied with the lift.

<b>WARNING</b>	<b>WARNING</b>	<b>WARNING</b>	<b>WARNING</b>	<b>WARNING</b>
<b>WARNING</b>	<b>WARNING</b>	<b>WARNING</b>	<b>WARNING</b>	
<small>The messages and pictures shown are generic in nature and are meant to generally indicate hazards common to all lifts regardless of specification. Funding for the development of these labels provided by the Autor Institute, PO Box 3311 FL 32903-3116. They are protected by Set of labels may be a AU or its member company. © 1992 by ALL Inc.</small>				

## TROUBLE SHOOTING

Trouble	Cause	Remedy
Motor does not run.	<ol style="list-style-type: none"> <li>1. Blown fuse or circuit breaker.</li> <li>2. Incorrect voltage to motor.</li> <li>3. Bad wiring connections.</li> <li>4. Transformer failure. (<i>inbay</i> 3Ø only)</li> <li>5. Motor up button switch failure.</li> <li>6. Motor relay failure (<i>inbay</i> only).</li> <li>7. Motor windings burned out.</li> </ol>	<ol style="list-style-type: none"> <li>1. Replace blown fuse or reset circuit breaker.</li> <li>2. Supply correct voltage to motor.</li> <li>3. Repair and insulate all connections.</li> <li>4. Check voltage on transformer secondary.</li> <li>5. Check and replace switch.</li> <li>6. Replace motor relay.</li> <li>7. Replace motor.</li> </ol>
Motor runs but will not raise lift.	<ol style="list-style-type: none"> <li>1. Open lowering valve.</li> <li>2. Pump sucking air.</li> <li>3. Suction stub off pump.</li> <li>4. Low fluid level.</li> </ol>	<ol style="list-style-type: none"> <li>1. Repair or replace lowering valve.</li> <li>2. Tighten all suction line fittings.</li> <li>3. Replace switch stub.</li> <li>4. Fill tank with Dexron III ATF or ISOVG32 Hydraulic Fluid.</li> </ol>
Motor runs-raises unloaded lift but will not raise vehicle.	<ol style="list-style-type: none"> <li>1. Motor running on low voltage.</li> <li>2. Debris in lowering valve</li> <li>3. Improper relief valve adjustment.</li> <li>4. Overloading lift.</li> </ol>	<ol style="list-style-type: none"> <li>1. Supply correct voltage to motor.</li> <li>2. Clean lowering valve.</li> <li>3. Replace relief valve cartridge.</li> <li>4. Check vehicle weight and/or balance vehicle weight on lift.</li> </ol>
Lift settles down.	<ol style="list-style-type: none"> <li>1. Debris in check valve seat.</li> <li>2. Debris in lowering valve seat.</li> <li>3. External fluid leaks.</li> </ol>	<ol style="list-style-type: none"> <li>1. Clean check valve.</li> <li>2. Clean lowering valve.</li> <li>3. Repair external leaks.</li> </ol>
Slow lifting speed or fluid blowing out fill-breather cap.	<ol style="list-style-type: none"> <li>1. Air mixed with fluid.</li> <li>2. Air mixed with fluid suction.</li> <li>3. Fluid return tube loose.</li> <li>4. Over-filled power unit fluid tank.</li> </ol>	<ol style="list-style-type: none"> <li>1. Change fluid to Dexron III ATF.</li> <li>2. Tighten all suction line fittings.</li> <li>3. Reinstall fluid return tube.</li> <li>4. Remove excess fluid to fill vent level.</li> </ol>
Lift "chattering" or jumping.	<ol style="list-style-type: none"> <li>1. Air is in the hydraulic system</li> <li>2. Bearings are dry</li> <li>3. Vehicle spotted incorrectly.</li> </ol>	<ol style="list-style-type: none"> <li>1. Bleed the hydraulic system.</li> <li>2. Grease the guide barrels.</li> <li>3. Re-spot vehicle per Fig. 1.</li> </ol>
Locking latch will not release.	<ol style="list-style-type: none"> <li>1. Dirty air line filter.</li> </ol>	<ol style="list-style-type: none"> <li>1. Clean air filter.</li> </ol>
LDS light is on ( <i>inbay</i> only).	Liquid Detected In Containment	<ol style="list-style-type: none"> <li>1. Liquid detected in containment</li> <li>2. Remove all liquid from lift containment.</li> <li>3. Call a Rotary Authorized Installer for assistance if needed.</li> <li>4. Press mode button again to resume lift operation.</li> <li>5. Inbay liquid detection system screen will display until lift containment has been emptied of liquid.</li> </ol>

## TROUBLE SHOOTING

Trouble	Cause	Remedy
LDS light is on ( <i>inbay</i> only).	Liquid Detected In Containment (No Liquid Found In Containment)  1. Possible Causes (Air System Fault)	1. Call a Rotary Authorized Installer for assistance. 2. Fault: Short in connection to sensor. Fix: Repair shorted connection. 3. Fault: Defective sensor. Fix: Replace sensor. 4. See air system diagram , Fig 7.
LDS light is on ( <i>inbay</i> only).	Liquid Detected In Containment (No Liquid Found In Containment)  1. Possible Causes (Pressure Sensor Fault)	1. Call a Rotary Authorized Installer for assistance. 2. Fault: Plugged or kinked sensor tube. Fix: Check by removing air connection to pressure sensor. If LDS (Liquid Detection System) error deactivates, blow out tube or repair kink. If LDS (Liquid Detection System) stays activated, replace pressure sensor. 3. See air system diagram Fig 7.

### DOWN Button Pressed But Lift Doesn't Lower

Trouble	Cause	Remedy
Lowering valve does not open ( <i>inbay</i> only).	1. Blown fuse or circuit breaker.  2. Transformer failure. (3Ø only)  3. Bad wiring connections. 4. Down button switch failure. 5. Defective latch air valve in master control panel.	1. Replace blown fuse or reset circuit breaker. 2. Check voltage on transformer secondary. 3. Repair and insulate all connections. 4. Replace switch. 5. Contact authorized Rotary repair person

## IMPORTANT

This lift requires periodic lubrication. Use only Mobil Mobilith® SHC® 1500 synthetic grease. See Owners Manual for lubrication procedures and proper vehicle spotting guide.

NP448 B Rev.

# LIFT LOCKOUT/TAGOUT PROCEDURE

## Purpose

This procedure establishes the minimum requirements for the lockout of energy that could cause injury to personnel by the operation of lifts in need of repair or being serviced. All employees shall comply with this procedure.

## Responsibility

The responsibility for assuring that this procedure is followed is binding upon all employees and service personnel from outside service companies (i.e., Authorized Rotary Installers, contractors, etc.). All employees shall be instructed in the safety significance of the lockout procedure by the facility owner/manager. Each new or transferred employee along with visiting outside service personnel shall be instructed by the owner/manager (or assigned designee) in the purpose and use of the lockout procedure.

## Preparation

Employees authorized to perform lockout shall ensure that the appropriate energy isolating device (i.e., circuit breaker, fuse, disconnect, etc.) is identified for the lift being locked out. Other such devices for other equipment may be located in close proximity of the appropriate energy isolating device. If the identity of the device is in question, see the shop supervisor for resolution. Assure that proper authorization is received prior to performing the lockout procedure.

## Sequence of Lockout Procedure

- 1) Notify all affected employees that a lockout is being performed and the reason for it.
- 2) Unload the subject lift. Shut it down and assure the disconnect switch is "OFF" if one is provided on the lift.
- 3) The authorized lockout person operates the main energy isolation device removing power to the subject lift.
  - If this is a lockable device, the authorized lockout person places the assigned padlock on the device to prevent its unintentional reactivation. An appropriate tag is applied stating the person's name, at least 3" x 6" in size, an easily noticeable color, and states not to operate device or remove tag.
  - If this device is a non-lockable circuit breaker or fuse, replace with a "dummy" device and tag it appropriately as mentioned above.
- 4) Attempt to operate lift to assure the lockout is working. Be sure to return any switches to the "OFF" position.
- 5) The equipment is now locked out and ready for the required maintenance or service.

## Restoring Equipment to Service

- 1) Assure the work on the lift is complete and the area is clear of tools, vehicles, and personnel.
- 2) At this point, the authorized person can remove the lock (or dummy circuit breaker or fuse) & tag and activate the energy isolating device so that the lift may again be placed into operation.

## Rules for Using Lockout Procedure

Use the Lockout Procedure whenever the lift is being repaired or serviced, waiting for repair when current operation could cause possible injury to personnel, or for any other situation when unintentional operation could injure personnel. No attempt shall be made to operate the lift when the energy isolating device is locked out.

# OPERATING CONDITIONS

**Lift is not intended for outdoor use and has an operating ambient temperature range of 41°-104°F (5°-40°C).**

APPROVED ACCESSORIES		
Item	Capacity	Part Number
Truck Adapter (For Flip-Up Adapter)	2500 lbs.	FJ6115
Truck Adapter (For Flip-Up Adapter)	2500 lbs.	FJ6133
Mini-Van Adapter (For Flip-Up Adapter)	1750 lbs.	FJ6137
Polymer Pad Adapter (For Flip-Up Adapter)	2500 lbs.	FJ6138
High Step Polymer Pad Adapter	2500 lbs.	FJ6139
1" Pad Adapter	2500 lbs.	FJ6190
Rubber Adapter for: SL210	2500 lbs.	FJ6182
Adapter for: SL210	2500 lbs.	FJ6191
3-1/2" Adapter Extension	2500 lbs.	FJ7880
5" Adapter Estension	2500 lbs.	FJ7880
Air/Electric Utility Box		FA5911
Air/Electric Utility Box Without FRL		FA5910
Filter/Regulator/Lubricator (FRL)		FA5166

## MANUAL LOWERING OF *inbay* AND SL210U LIFTS

If your lift is in a raised position and you lose power it is important to know how to lower the lift manually. Make sure nothing is under the lift and all unauthorized personnel are away from the lift area.

1. Place a hydraulic jack and pipe under one of the arm carriages. Jack should be rated to lift the capacity of the vehicle.
2. Raise lift off of the locking latch. You should only have to raise lift approximately 1/6" to disengage the lock.
3. Remove access panel from the master control panel. As you are facing the master control panel look slightly down and to the right and you will see the air latch valve, Figs. 11a and 11b.
4. Depress the button on the top of the air valve, Figs. 11a and 11b. At this time you should hear the air leave the lift. Do not use a sharp object to depress the button.
5. Slowly lower hydraulic jack and pipe out from under the arm carriage. The lift is now being held up by hydraulics at this point.
6. Remove cap from lowering valve and twist and pull to lower lift, Figs. 11a and 11b. The lift will lower at a slow speed. Replace cap on lowering valve after lift has been lowered.
7. If your facility lost power your lift will operate when you regain power.
8. If your facility power was not lost have a certified electrician check wiring to lift or call an authorized Rotary repair person.

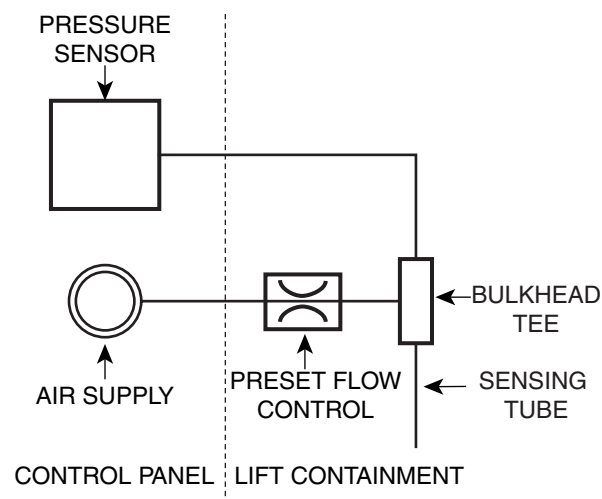

Master Control

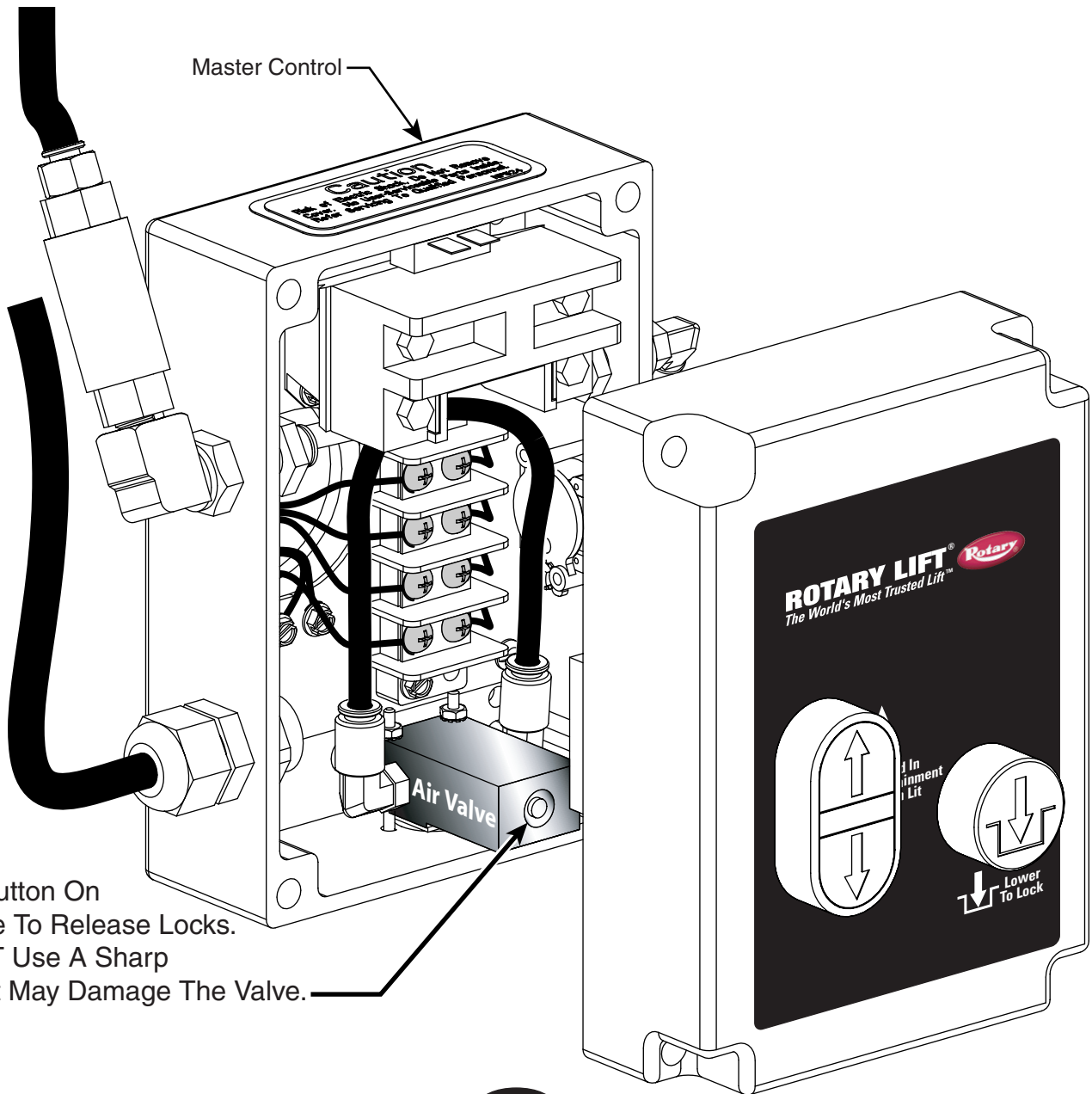

Press Button On  
Air Valve To Release Locks.  
DO NOT Use A Sharp  
Object It May Damage The Valve.

Fig. 11a

Twist And Pull  
To Manually Override

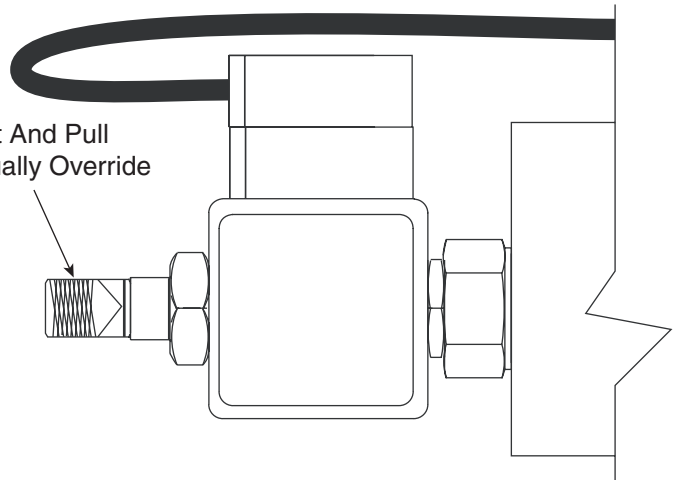

SIDE VIEW OF  
LOWERING VALVE  
LOCATED ON  
POWERUNIT

Press Button On Top Of a Air Valve to release locks.  
 DO NOT Use A Sharp Object It May Damage The Valve.

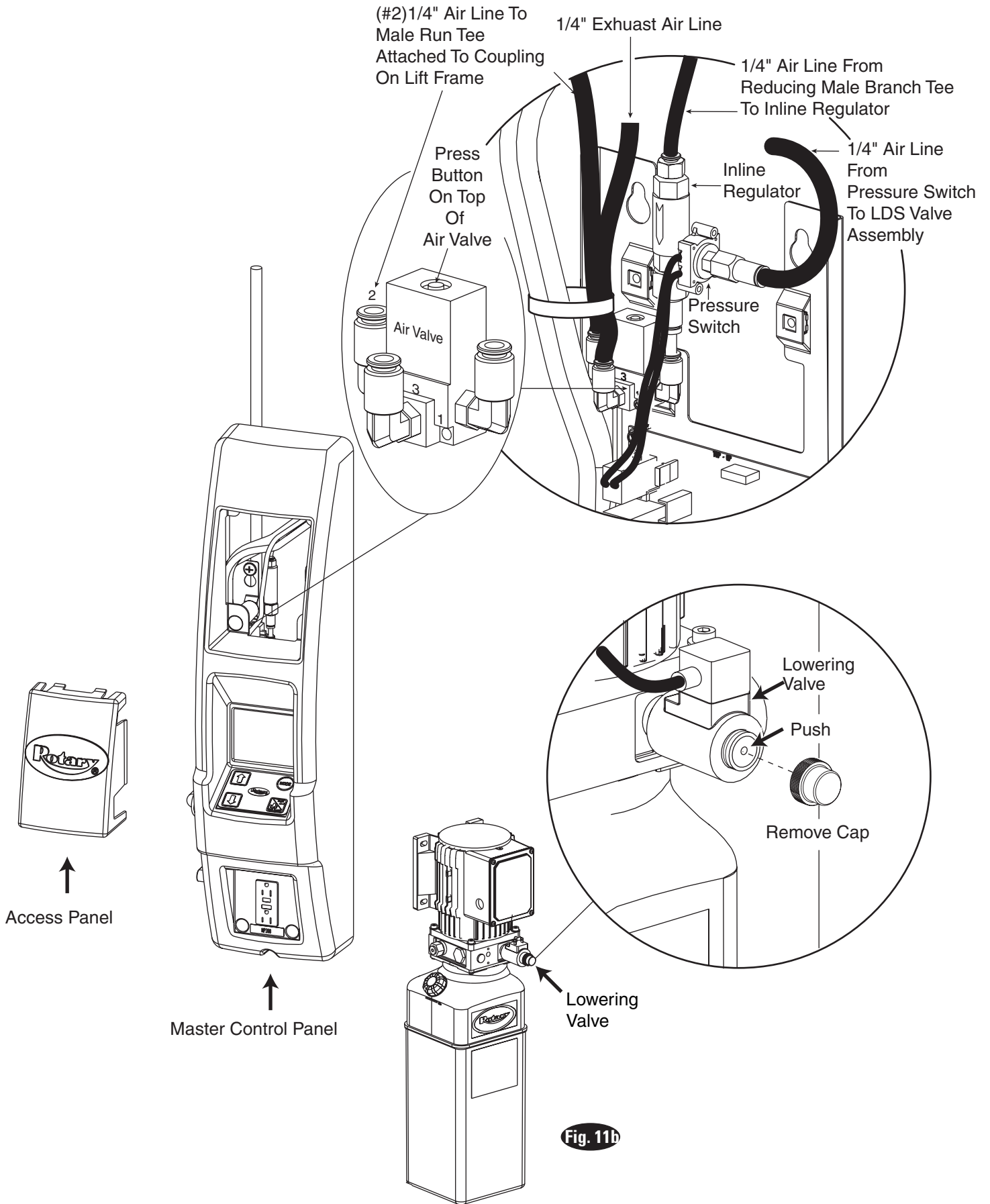
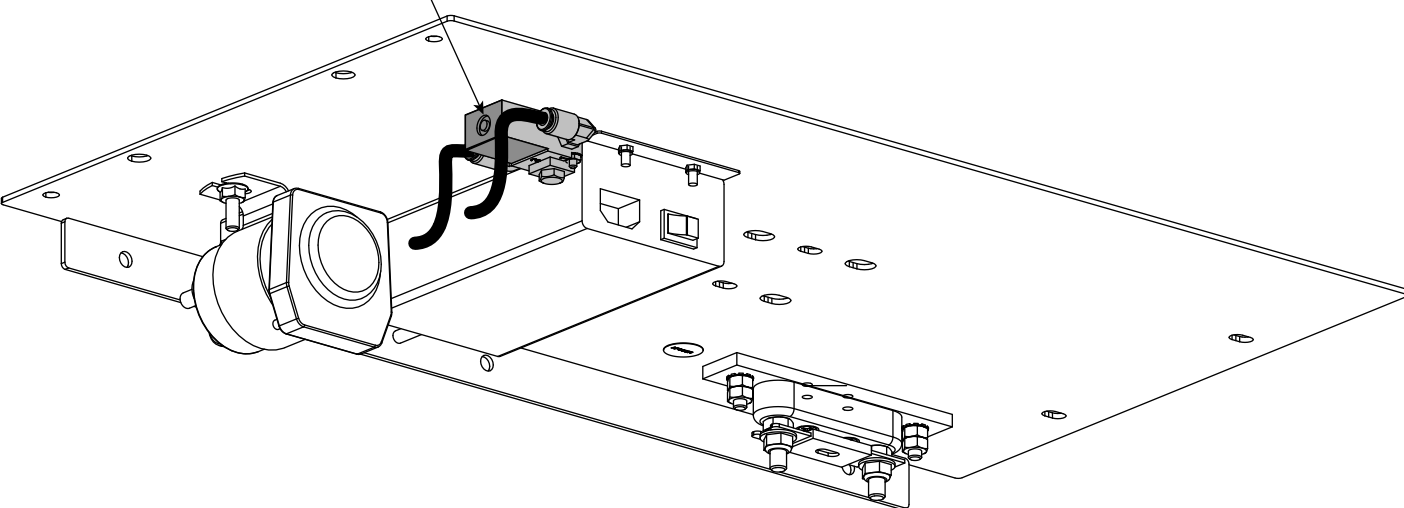

Fig. 11b

# ShockWave Manual Lowering Top Of Control Panel Simplified Representation

Press Button On  
Air Valve To Release Locks.  
DO NOT Use A Sharp  
Object It May Damage The Valve.



Twist And Pull  
To Manually Override

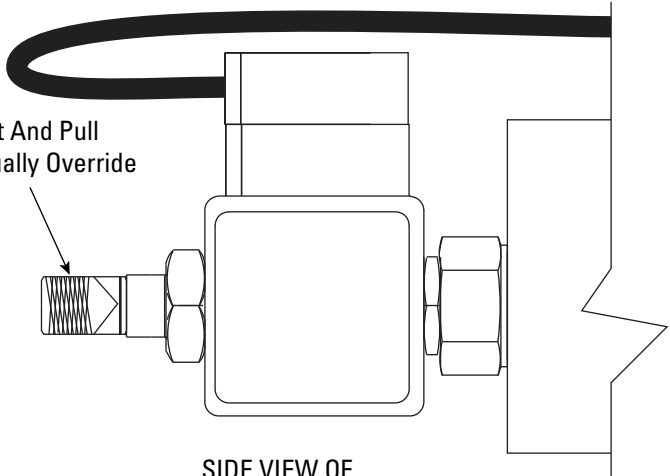

SIDE VIEW OF  
LOWERING VALVE  
LOCATED ON  
POWERUNIT



NOTES:

NOTES:

NOTES:

# Certificate of Compliance

*Rotary Lift is authorized to apply ETL & cETL Listing Marks/Labels to this AC Motor. Authorization: ETL Report No. J98007541-003, FAM -UL73 . This ETL test certifies that this AC Motor complies with Underwriters Laboratories, Inc. standard ANSI/UL 73, 8th Edition & CSA standard C22.2 No. 68-92.*



SV0021 A Rev. 6/9/99

## Trained Operators and Regular Maintenance Ensures Satisfactory Performance of Your Rotary Lift.

**Replacement Parts:** See installers package for parts breakdown sheet. Order Genuine Rotary replacement parts from your nearest Authorized Parts Distributor.

**Maintenance Assistance:** Contact your local Rotary distributor.

Should further assistance be required, contact Rotary Lift, at one of the phone numbers listed below.

DATE	REV.	CHANGE MADE
08-15-07	-	New 800 Series.
06-29-10	A	Added 3-Stage arm adapter graphics
12-08-11	B	Added ShockWave manual Lowering

### Rotary World Headquarters

2700 Lanier Drive  
Madison, IN 47250, USA  
[www.rotarylif.com](http://www.rotarylif.com)

### North America Contact Information

Tech. Support: p 800.445.5438  
f 800.578.5438  
e [userlink@rotarylif.com](mailto:userlink@rotarylif.com)  
Sales: p 800.640.5438  
f 800.578.5438  
e [userlink@rotarylif.com](mailto:userlink@rotarylif.com)

### World Wide Contact Information

World Headquarters/USA: 1.812.273.1622  
Canada: 1.905.812.9920  
European Headquarters/Germany: +49.771.9233.0  
United Kingdom: +44.178.747.7711  
Australasia: +60.3.7660.0285  
Latin America / Caribbean: +54.3488.431.608  
Middle East / Northern Africa: +49.771.9233.0



A DOVER COMPANY

