

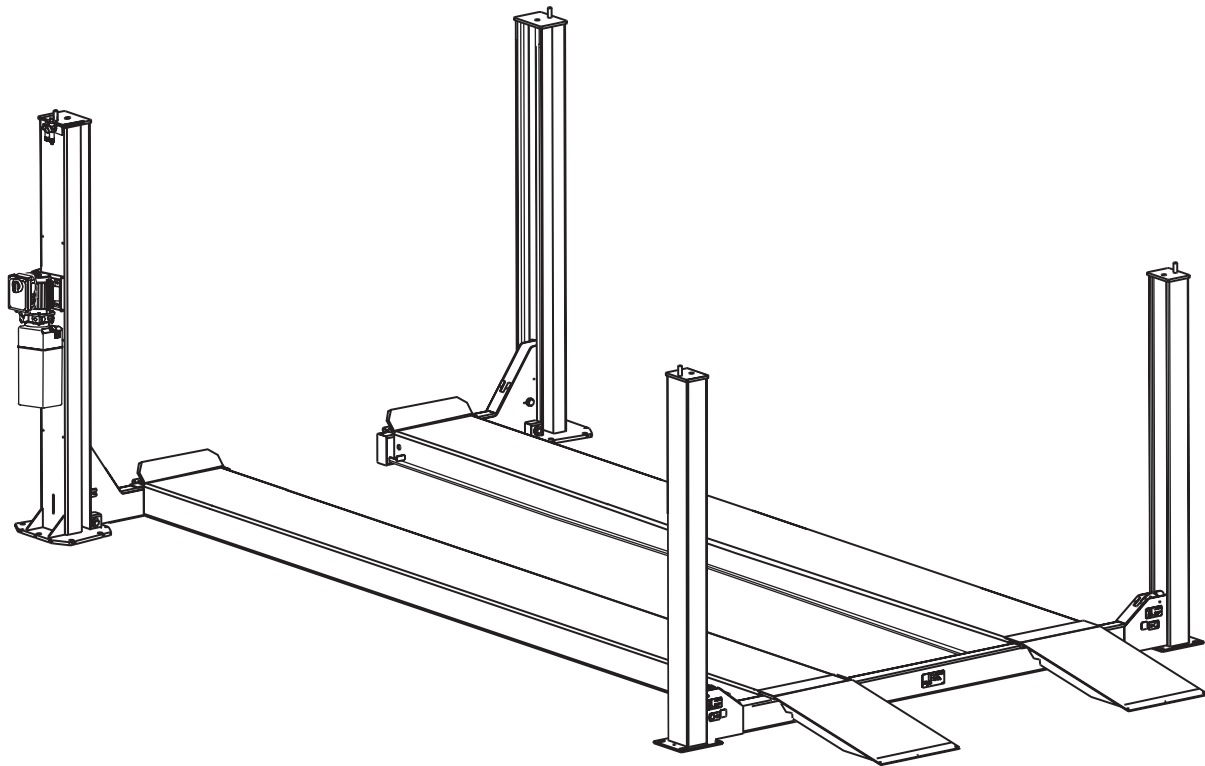

AR014/SM014

Four Post Surface Mounted Lift
Capacity 14,000 lbs. (7,000 lbs. per axle)
Maximum Wheelbases of 212-1/2", 192-1/2" & 158-1/2"



I
N
S
T
A
L
L
A
T
I
O
N

I
N
S
T
R
U
C
T
I
O
N
S

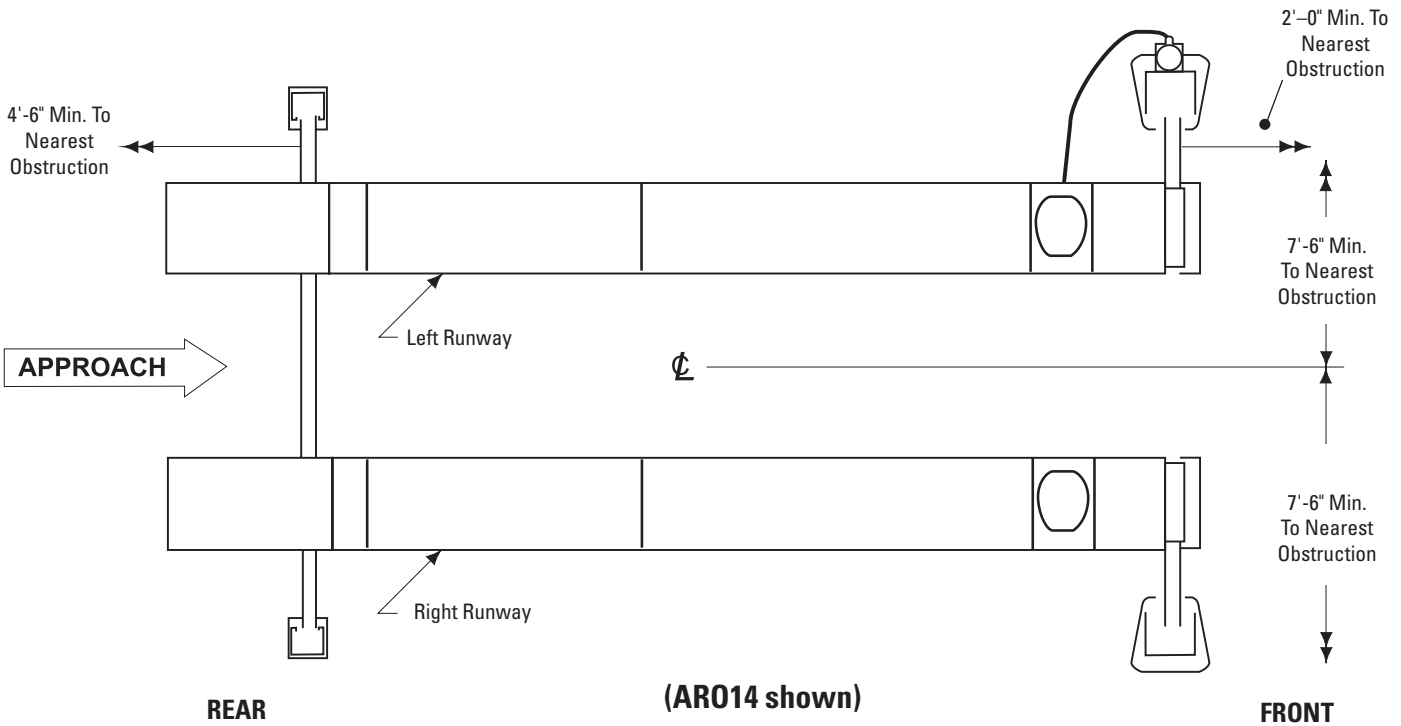

Fig. 1

Read and understand these instructions completely before proceeding with lift installation.

1. Lift Location: Use architects plan when available to locate lift. Fig. 1 shows dimensions of a typical bay layout. Lift floor area should be level.

⚠ WARNING DO NOT install on asphalt or other similar unstable surface. Columns are supported only by anchors in floor

2. Ceiling or overhead clearance must be 80" plus height of tallest vehicle.

3. Estimating Column Shim requirements: In the following section, the terms "highest" and "lowest" refer to elevation of floor.

- A. Mark locations where lift columns will be positioned in bay.
- B. Place target on floor at column positions (NOT on column base plates) and record readings, Fig. 2.
- C. Find the highest of the four locations. Find the difference between the reading at each of the remaining three columns and the highest reading.
- D. The difference is the estimated amount of shim thickness needed at each column.

Note: Maximum shim thickness is 1/2" per column using shims and anchors provided with lift. Shim thickness of 2" is possible by using optional shim kit and longer anchors. Contact your authorized Rotary Parts Distributor for ordering information.

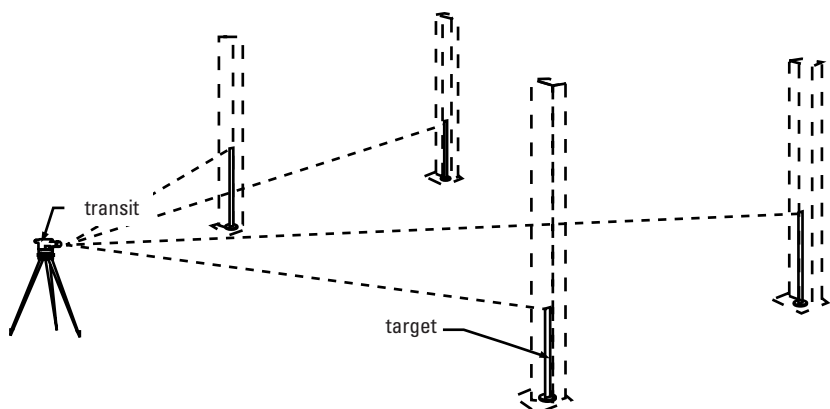

Note: Target is positioned on floor at planned column positions (**NOT** on column base plates).

Dimension at highest position minus other position equal shim thickness required

Fig. 2

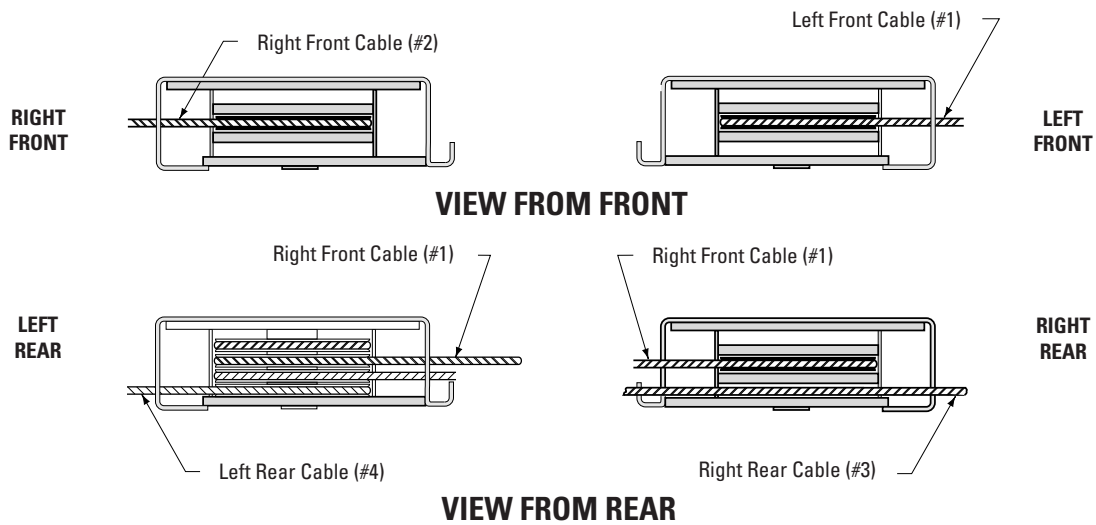
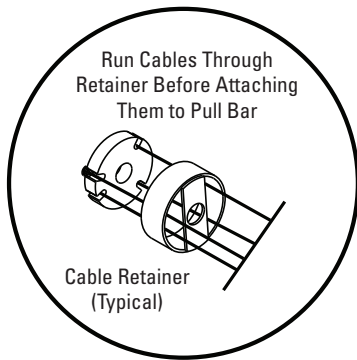

Fig. 3

4. Attaching Runways to Rear Yoke:

- A. Determine direction of approach in bay.
- B. Position left runway in bay with hydraulic cylinder hose connection to rear of bay. Cables and sheaves are pre-assembled in left runway but not in the right runway. Runway needs to be up off floor so shipping restraints can be removed from cable ends, air and hydraulic lines, and cylinder rod. Pull cable ends, air, and hydraulic lines out for assembly.

- C. Position rear yoke at end of runways. The opening in the side of the yoke should be lined up with the cable sheaves in the runway ends. Feed cable ends through yoke openings. Be sure cables are not crossed inside yoke. Feed cable #1 through right runway, Fig. 3 and 4. Assemble sheaves and bearings into both ends of right runway, Fig. 5. Make sure cables are in proper sheave grooves, Fig. 3. Do not assemble sheaves in yoke ends at this time.



Do Not Cross Cables

Cable Retainer Not Shown to Clarify Cable Roping Illustration

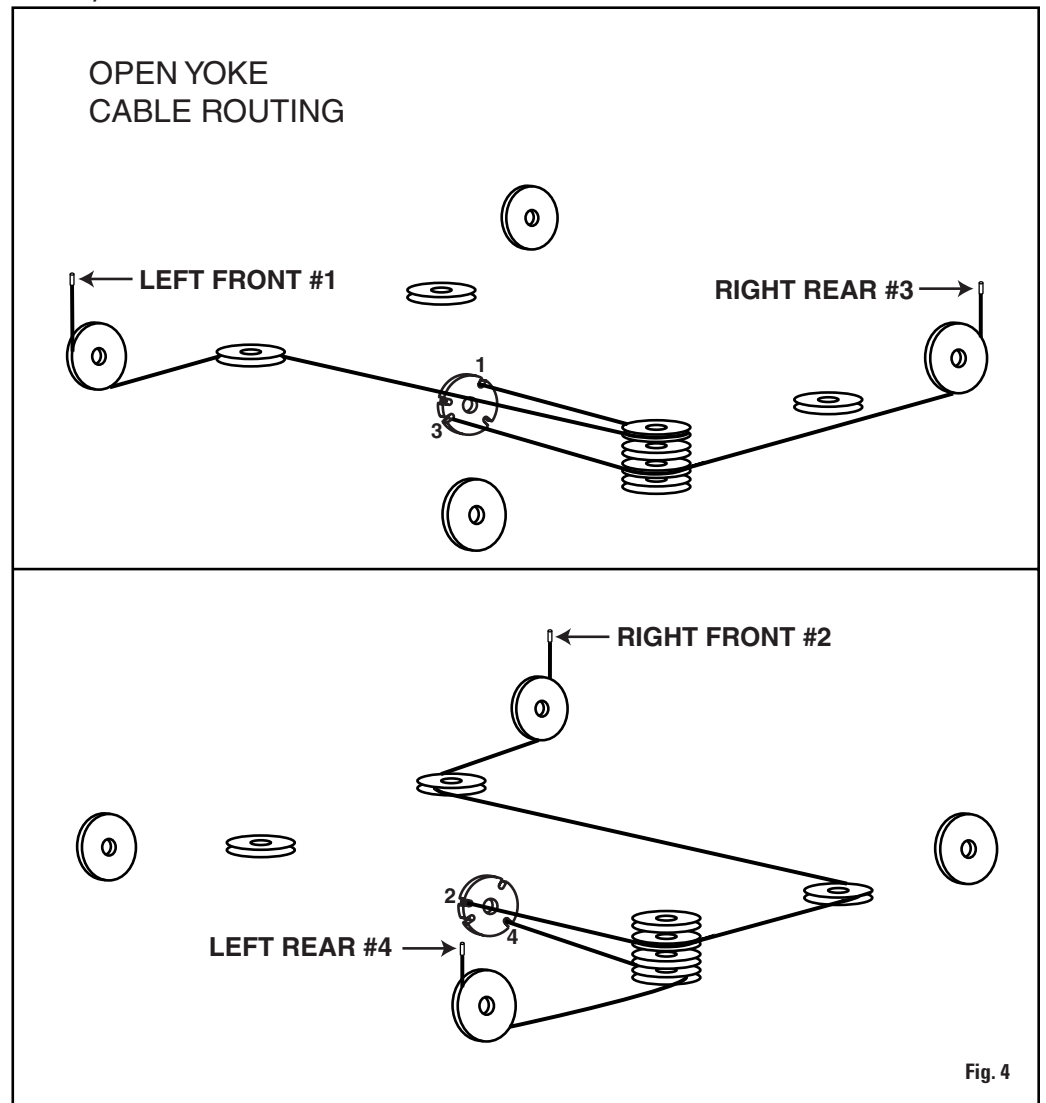

Fig. 4

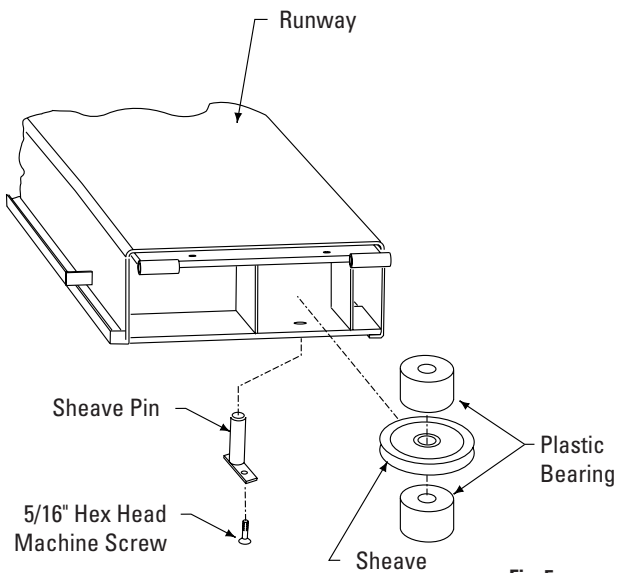

Fig. 5

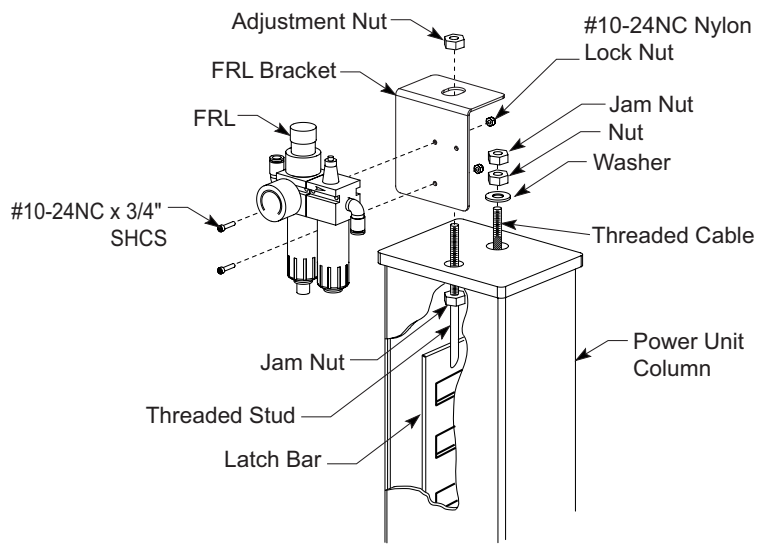

Fig. 7a

- D. With the openings in the rear yoke tubes side lined up with the runway ends, align the four (4) holes in the top of the yoke tubes with the slots in the runway end plates. Bolt runways to the rear yoke using four 1/2" x 1-1/4" hex flange bolts, Fig. 6.

5. Rear Yoke and Column:

- A. Place the rear column at the left corner of the lift. Position remaining rear column.
- B. Thread the jam nut down the threaded stud of the latch bar as far as possible. Attach rubber bumper to latch bar, see Fig. 8. Place the latch bar into the back of the column. The latch bar is offset from the center line of the threaded stud. The latch bar should be oriented toward the back of the column from center line of the threaded stud, Fig. 7b. Thread the adjustment nut down the threaded stud until the nut and top plate are flush, Fig. 7a. Repeat for other columns.
- C. Install rear yoke end sheaves and plastic spacers, Fig. 9. A plastic spacer is placed on each side of the sheave, see inset, Fig. 9. Retain with sheave pin and 5/16" button head machine screw.

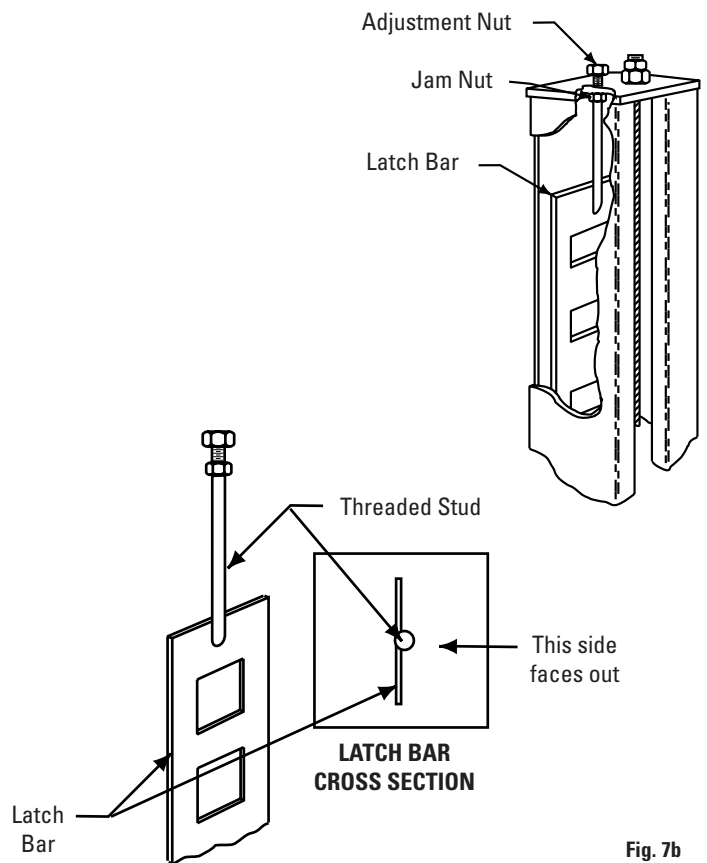

Fig. 7b

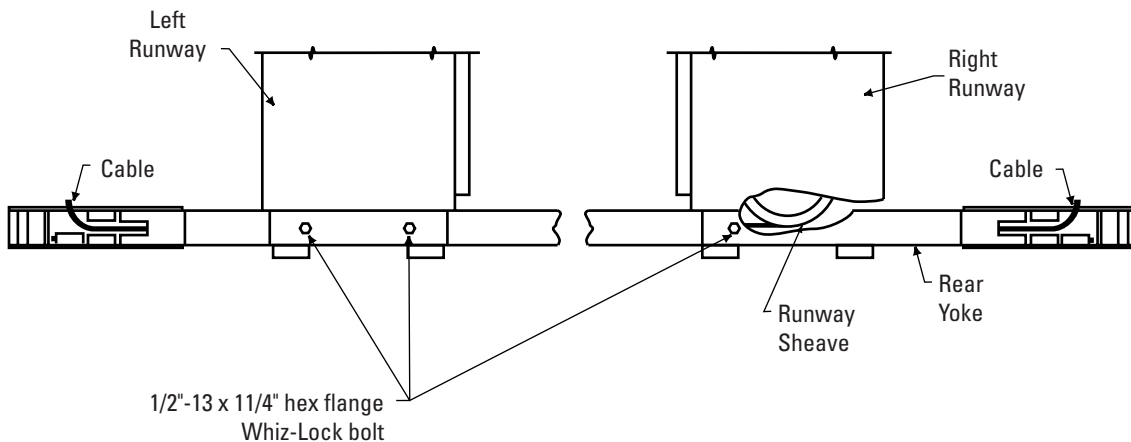
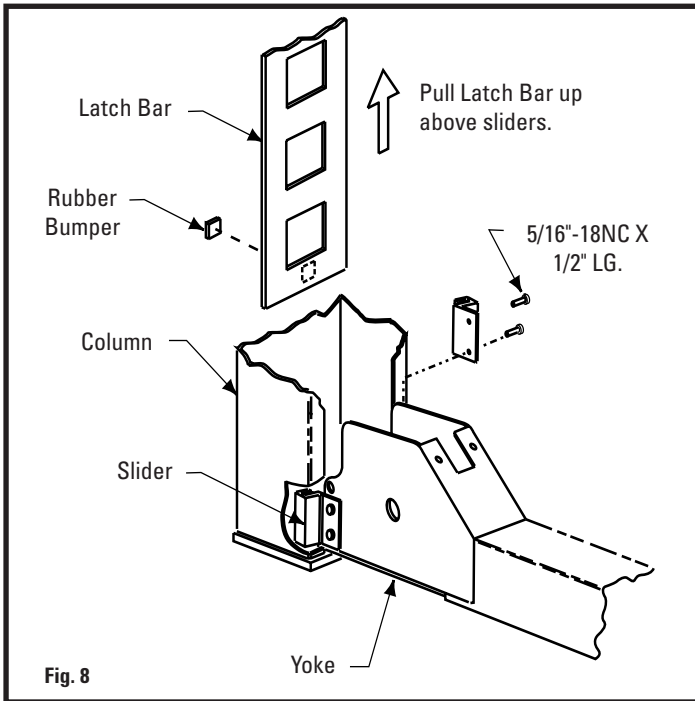

Fig. 6

- D. Start yoke end into the column, allowing slider bolt holes to stay exposed, Fig. 8. Apply thread locking compound to screw threads then bolt sliders onto each side of the yoke end with 5/16" screws provided. When both sliders are attached, push column toward yoke end until sliders touch latch bar.
- E. Raise latch bar above sliders and move column toward yoke until the sliders contact the back of the column.



Lower the latch bar into the sliders. Tighten latch bar jam nut against column top plate. Run latch bar adjustment nut down and tighten. The latch bar should engage the sliders for at least 1" when the lift is completely lowered. Repeat this procedure for each rear yoke end and column.

- F. **IMPORTANT** Be sure cable is isolated in the sheave groove. Attach each cable to column top plate with washer, nut, and jam nut, Fig. 9. Install rubber sheave guard on each yoke end. Roping diagram shows a view of completed roping, Fig. 4.

Note: Failure to install plastic spacers and bearings will result in premature failure and void warranty.

6. Front Latch Bar Install:

Note: Front columns are the taller columns.

- A. Place power unit column at the left front corner of lift.
- B. Install latch bars into front columns following Steps 5(A) to 5(C). Secure bottom of latch bar with long bolt, washer and nut, Fig. 10.
- C. Place FRL Bracket on top of power unit column. Guide the threaded stud through the hole in the column top plate and bracket, Fig. 7a.

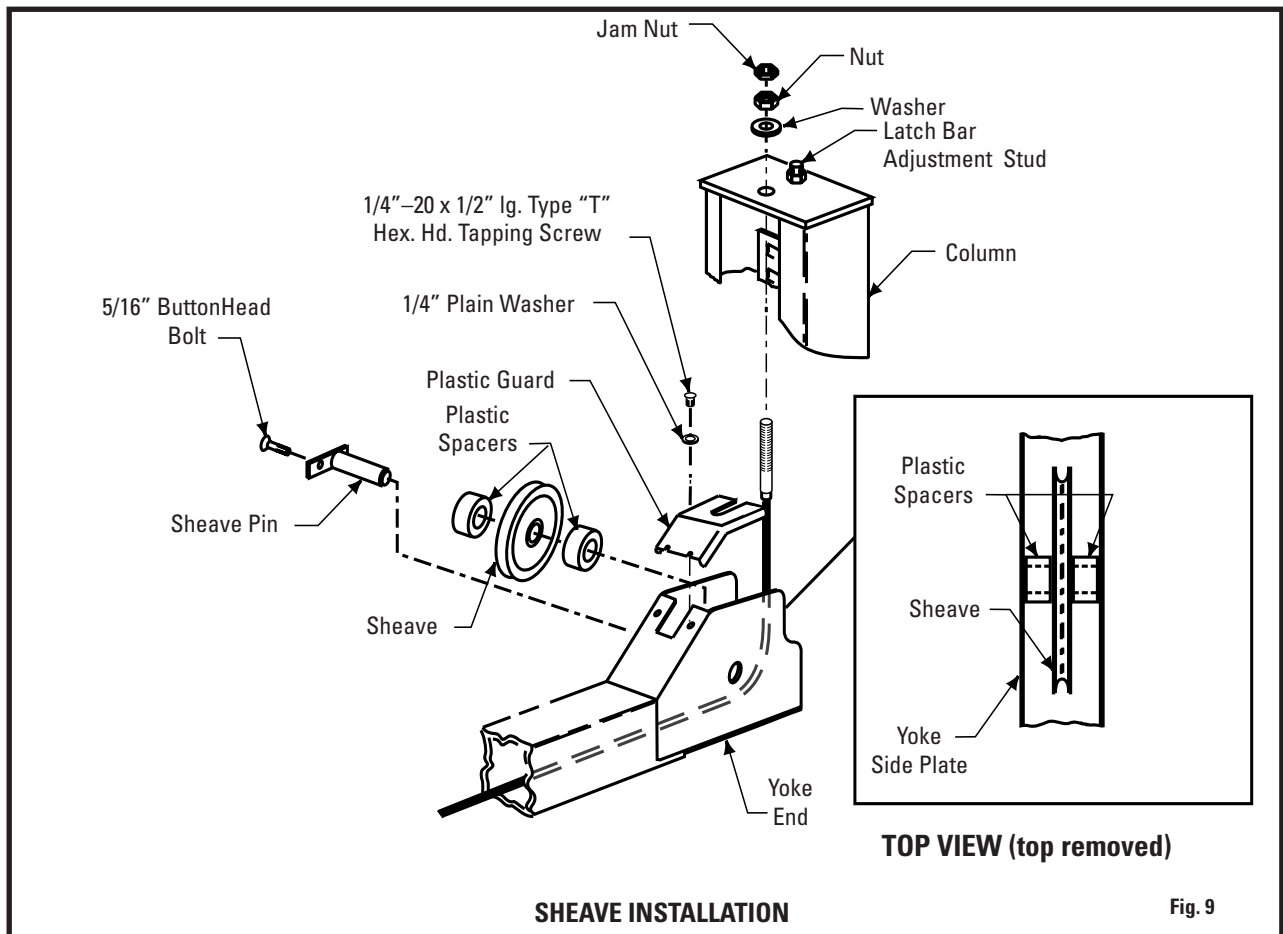

7. Front Yoke Roller Assembly: Assemble yoke rollers and bearings for both front yokes, Fig 11.

ATTENTION Do not apply grease to rollers or pins.

- A. Slip a disc spacer onto each of the four roller pins.
- B. Assemble roller and slider onto top pins.
- C. Assemble roller and bearing onto lower pins. Secure roller cover, open side toward column, with 5/8" flat washer and 5/8" x 1" lg. bolt.

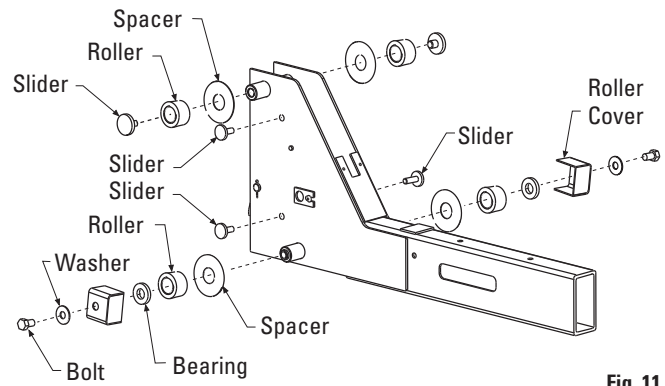

Fig. 11

ATTENTION Do not apply grease to rollers or pins.

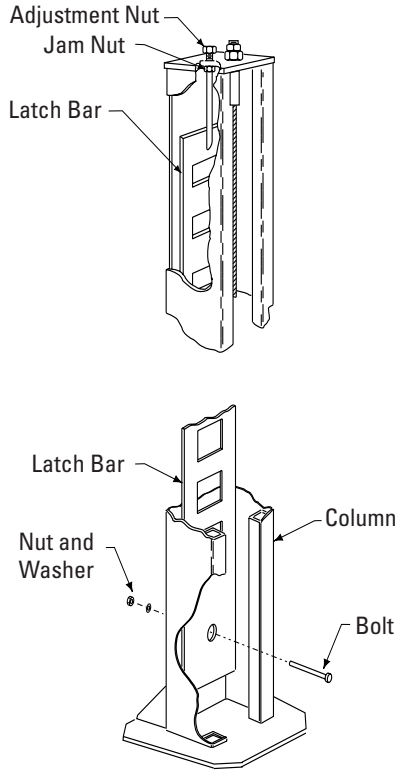

Fig. 10

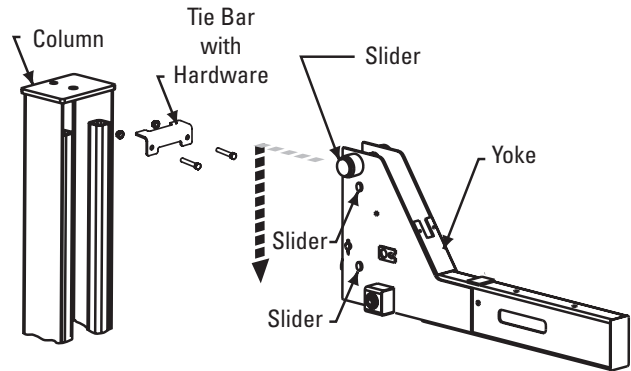

Fig. 12

- D. Insert the slider into the 3/4" hole in each yoke side plate.
8. Lay column down, with back of column to the floor. Remove tie bar attached near the top of column tubes. Slide yoke into the top of the column and slide to bottom of column, Fig. 12. Reinstall the tie bar.
9. Raise yoke and column assembly to upright position and slide yoke under runway end. The opening in the side of the yoke should be lined up with the cable sheaves in the runway ends. Feed cable ends through yoke openings. Align bolt holes in top of yokes with slots in runways. Attach runway to the front yoke using a single 1/2" x 1-1/4" flanged hex head bolt inserted in the outside hole of each runway.

10. Front Sheave Install: Install yoke end sheaves and plastic bearings. A plastic bearing is placed between each side of the sheave and the sheave spacers, Fig. 13, also refer to inset in Fig. 9. Retain with sheave pin and 5/16" button head machine screw. Be sure cable is located in the sheave groove.

11. Cable Install: Attach each cable to column top plate with nut, jam nut, and washer, Fig. 13. Install rubber sheave guard on each yoke end.

Note: Cable tube spacer is not used on front column cables.

12. Concrete and Anchoring:

- A. Square up runways. Install spacer bar and bolts, to help maintain the runway spacing, Fig. 14. Adjust runways until diagonals are equal. Check lift location in the bay. Check dimensions side-to-side, equal to within 1/8", Fig. 15.

CAUTION DO NOT install on asphalt or other similar unstable surfaces. Columns are supported only by anchors in floor.

B. Rear Column Install.

1. Move rear column towards yoke until the sliders contact the back of column. Center yoke in column, Fig. 16.
2. Place shims (estimated from Step 3) under each column. Drill four 5/8" diameter holes through concrete floor using holes in baseplate as guide, Fig. 17.
3. Insert anchors with washers, Fig. 17. 5/8" anchors must have a minimum anchor embedment of 2-3/4". If the top of the anchor exceeds 1-1/2" above the floor grade, you DO NOT have enough embedment.
4. Tighten 5/8" anchor bolts to an installation torque of 60 ft-lbs. Shim thickness MUST NOT exceed 1/2" when using the standard anchors provided with the lift. Check columns for plumb. Re-shim if necessary. Repeat for other column. If anchors do not tighten to required installation torque, replace concrete under each column base with a 4' x 4' x 6" thick 3000 PSI minimum concrete pad keyed under and flush with the top of existing floor. Let concrete cure before installing lifts and anchors.

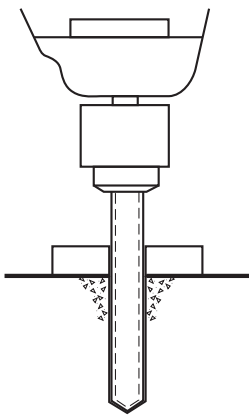

Drill holes using carbide tipped masonry drill bit per ANSI B212.15-1994 (R2000)

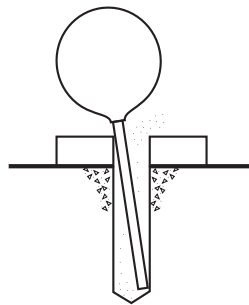

Clean hole.

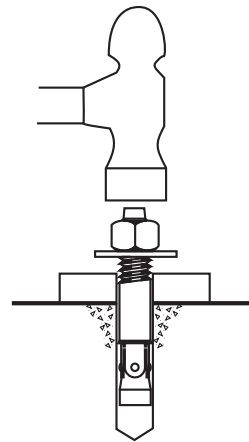

Run nut down just below impact section of bolt. Drive anchor into hole until nut and washer contact base.

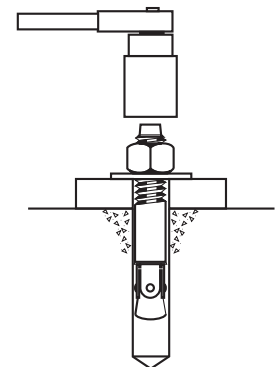

Tighten nut with Torque wrench:

5/8" rear column anchors 60 ft.-lbs.

3/4" front column anchors 110 ft.-lbs.

C. Front Column Anchoring:

1. If necessary, readjust runways until diagonals are equal. Remove Spacing Tool and reattach yoke/runway bolts. Hold runway spacing at 43".
2. Position front column where both outer yoke wheels are in contact with the column. Shim and plumb front of column, taking care to push column in to contact lower rollers. Push opposite column in to contact rollers.
3. Drill five 3/4" holes through concrete floor using holes in baseplate as guide.
4. Insert anchors with washers, Fig. 18. 3/4" anchors must have a minimum anchor embedment of 3-1/4". If the top of the anchor exceeds 2-1/4" above the floor grade, you DO NOT have enough embedment.
5. Tighten 3/4" anchor bolts to an installation torque of 110 ft-lbs. Shim thickness MUST NOT exceed 1/2" when using the standard anchors provided with the lift. Check columns for plumb. Re-shim if necessary. Repeat for other column. If anchors do not tighten to required installation torque, replace concrete under each column base with a 4' x 4' x 6" thick 3000 PSI minimum concrete pad keyed under and flush with the top of existing floor. Let concrete cure before installing lifts and anchors.

CONCRETE AND 3/4" ANCHORING REQUIREMENTS

STANDARD	ANSI/ALI ALCTV:2006	IBC 2006, 2009, 2012		SEISMIC
Minimum Floor Thickness	4-1/4 INCHES	5 INCHES	6 INCHES	Varies by location consult with your structural engineer and manufacturer's representative.
Anchor	Hilti Kwik Bolt III* 3/4" x 5-1/2"	Hilti HIT-HY 150MAX-SD Adhesive; Hilti HIT-HY 150 MAX Adhesive; HILTI HIT-RE 500-SD Adhesive	Hilti Kwik Bolt III 3/4" x 7"	
Minimum Concrete Strength	3000 PSI	3000 PSI	3000 PSI	
Minimum Anchor Embedment	3-1/4 INCHES	3-1/2 INCHES	3-3/4 INCHES	
Minimum Distance to Concrete Edge, Crack, Expansion Joint, Abandoned Anchor Hole	4-1/2 INCHES	5-1/4 INCHES	3-1/4 INCHES	

***The supplied concrete fasteners meet the criteria of the American National Standard "Automotive Lifts - Safety Requirements for Construction, Testing, and Validation" ANSI/ALI ALCTV-2011, and the lift owner is responsible for all charges related to any additional anchoring requirements as specified by local codes. Contact customer service for further information at: 800.445.5438**

CONCRETE AND 5/8" ANCHORING REQUIREMENTS

STANDARD	ANSI/ALI ALCTV:2006	IBC 2006, 2009,2012		SEISMIC
Minimum Floor Thickness	4-1/4 INCHES	4-3/8 INCHES	5 INCHES	Varies by location consult with your structural engineer and manufacturer's representative.
Anchor	Hilti Kwik Bolt III* 5/8" x 4-1/4"	Hilti HIT-HY 150MAX-SD Adhesive; Hilti HIT-HY 150 MAX Adhesive; HILTI HIT-RE 500-SD Adhesive	Hilti Kwik Bolt III 5/8" x 6"	
Minimum Concrete Strength	3000 PSI	3000 PSI	3000 PSI	
Minimum Anchor Embedment	2-3/4 INCHES	3-1/8 INCHES	3-1/8 INCHES	
Minimum Distance to Concrete Edge, Crack, Expansion Joint, Abandoned Anchor Hole	4-1/2 INCHES	3-1/8 INCHES	2-1/4 INCHES	

***The supplied concrete fasteners meet the criteria of the American National Standard "Automotive Lifts - Safety Requirements for Construction, Testing, and Validation" ANSI/ALI ALCTV-2011, and the lift owner is responsible for all charges related to any additional anchoring requirements as specified by local codes. Contact customer service for further information at: 800.445.5438**

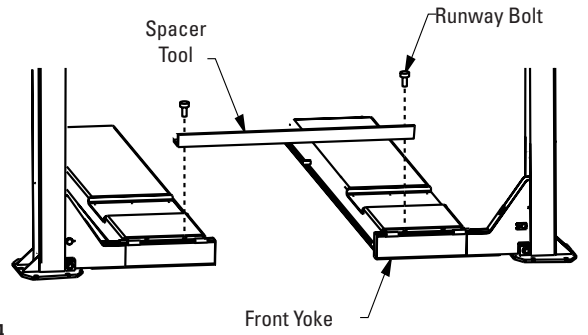
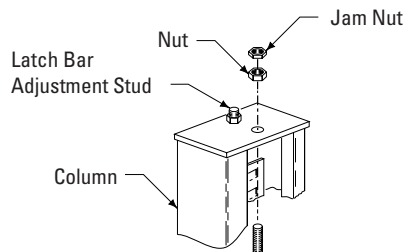

Fig. 14

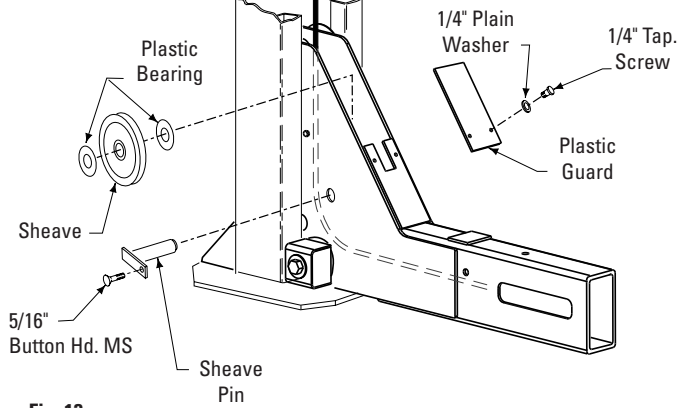

Fig. 13

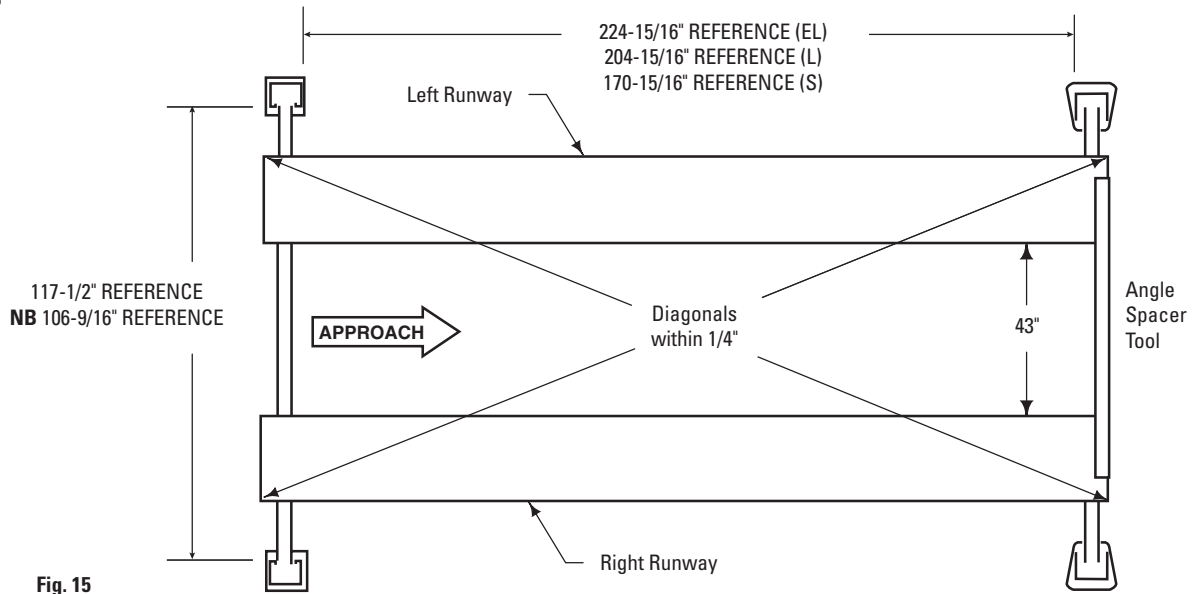
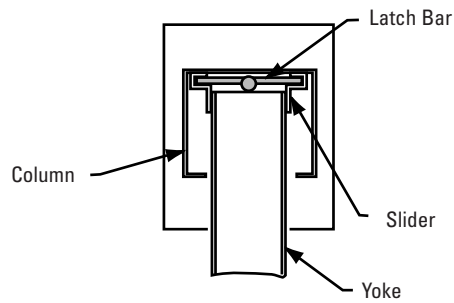

Fig. 15



Column Cross Section

Fig. 16

13. Runway Leveling:

- A. Use an engineer's automatic level (transit). Locate the Level at a convenient location in the shop that allows an unobstructed view of all four corners of the lift's runways. Follow the Level manufacturer's instructions for proper setup. Be sure it is adjusted level in all directions. Readjust level if it or tripod is bumped or disturbed.
- B. Make sure yoke tubes rest on column base plate.
- C. First place the Level target at the highest corner of the lift. Place it on the runway center line within 6" of yoke tube, whichever one is located over highest point. This will be referred to as target "A" position. Beginning with target "A" position, Fig. 18a, sight the Level to the target and mark the number or the graduation on the inch scale of the target that aligns to the crosshairs of the Level, Fig. 18b.

RUNWAYS SHOULD BE LEVEL MAXIMUM TOLERANCE SIDE TO SIDE AND FRONT TO REAR 1/8" (SEE PAGE 20 FOR AR014)

Note: Use a pencil, marking pen or attach a paper clip on to the target scale at the crosshair reference.

- D. Next, move the target and place it on the runway at point "B", Fig. 18a. Rotate the Level and focus on the target scale. Adjust the column at "B" using shims under base plate, Figs. 17 and 18, until the cross-hairs of Level align to reference mark on the target scale. Repeat for points C and D.

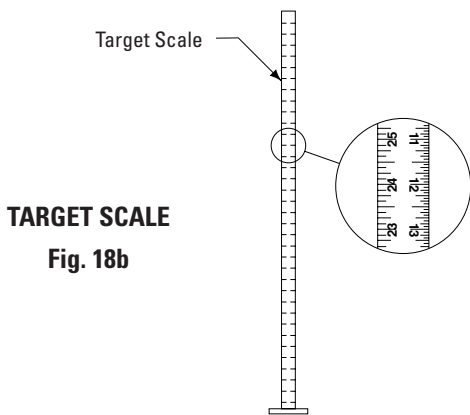

TARGET SCALE

Fig. 18b

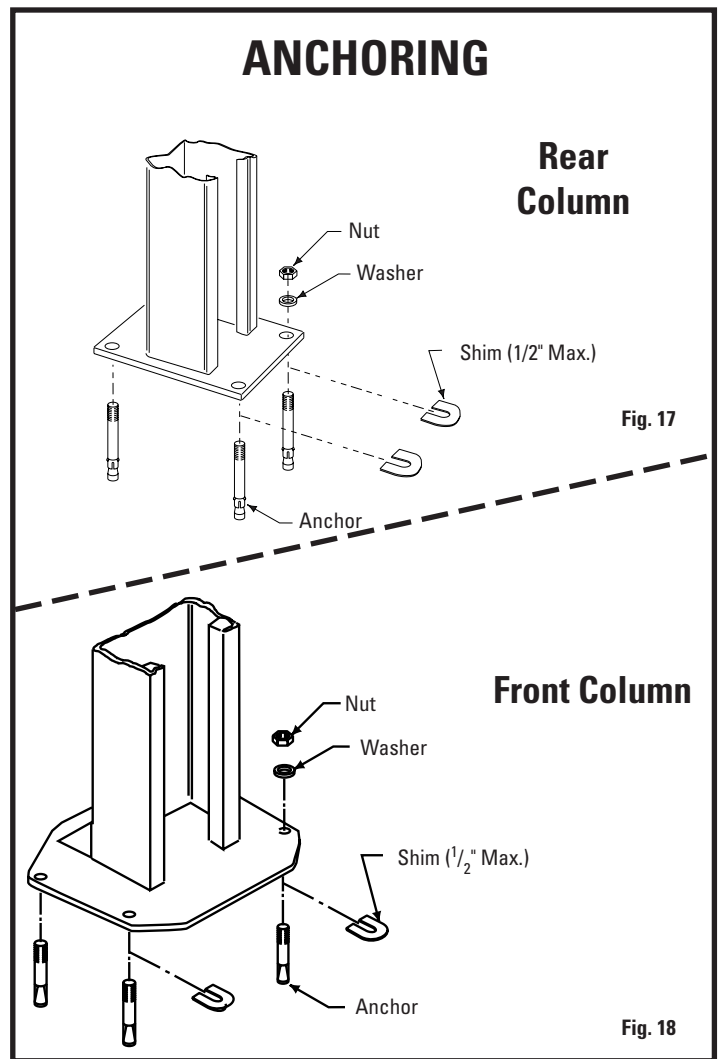

Fig. 17

Fig. 18

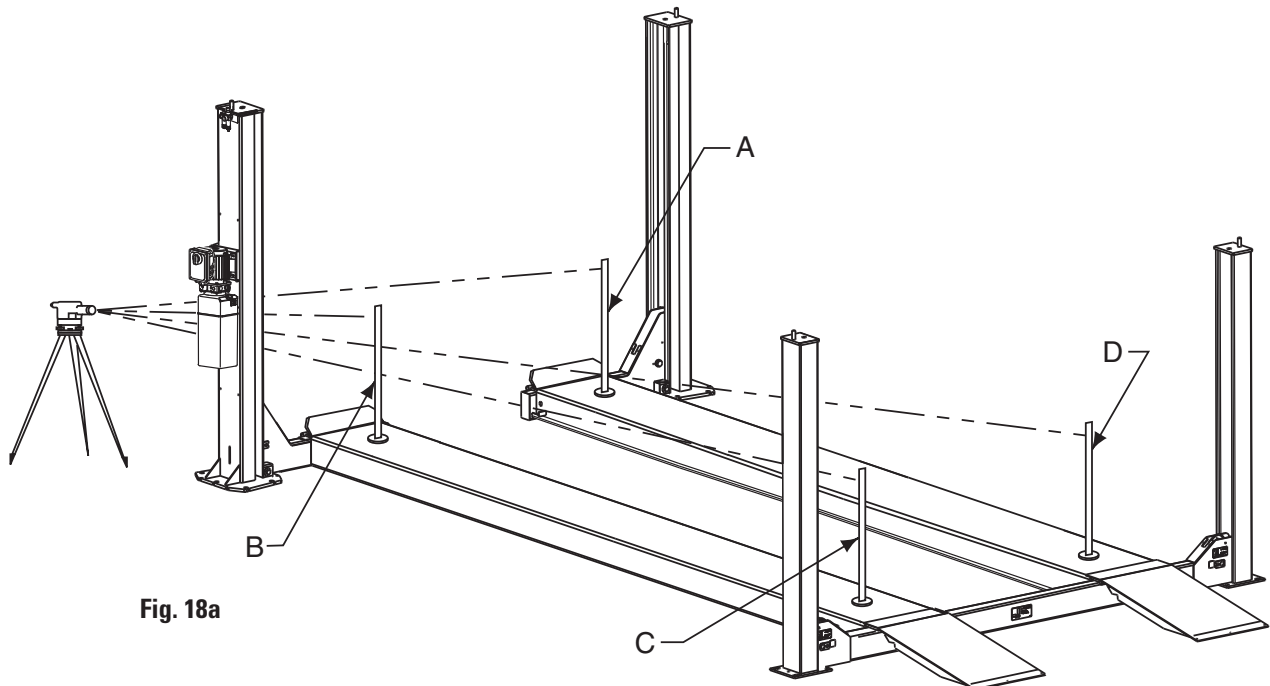

Fig. 18a

14. Cable Adjustment:

Adjust cable with lift fully lowered. Loosen jam nut and tighten nut on cable stud on top of column until yoke end raises 1/4". Back off nut one turn. Retighten jam nut. Repeat for all four cables. Cables must fit in slack cable arm rollers, Fig. 19.

15. Power Unit:

- A. Put (4) 5/16" x 1-1/2" hex bolts through holes in column bracket using push nuts to hold in place.
- B. Mount power unit, with motor up, to column bracket and install lock washers and nuts, Fig. 20. Run hydraulic hose from runway through slot in side of runway to power unit output port, Fig. 22. DO NOT use Teflon tape on hydraulic hose connections.
- C. Install and hand tighten elbow to pump until O-ring is seated and elbow is oriented downward at approximately 45°, Fig. 21. Continue to tighten the locknut to 10-15 ft-lbs., or until the nut and washer bottom out against the pump manifold. NOTE: You may still be able to rotate the elbow. This is acceptable unless there is seepage at the o-ring. If so, slightly tighten the locknut.
- D. Run hydraulic hose from runway through slot in side of runway to elbow, Fig. 22. DO NOT use Teflon tape on hydraulic hose connections. Clean elbow and hose. Inspect all threads for damage and hose ends to be sure they are crimped. Attach hose to elbow using Flared Fittings Tightening Procedure.

Flared Fittings Tightening Procedure

1. Screw the fitting together finger tight. Then, using the proper size wrench, rotate the fitting 2-1/2 hex flats.

IMPORTANT Flare seat MUST NOT rotate when tightening. Only the nut should turn.

2. Back the fitting off one full turn.
3. Again tighten the fittings finger tight; then using a wrench, rotate the fitting 2-1/2 hex flats. This will complete the tightening procedure and develop a pressure tight seal.

CAUTION Overtightening will damage fitting resulting in fluid leakage.

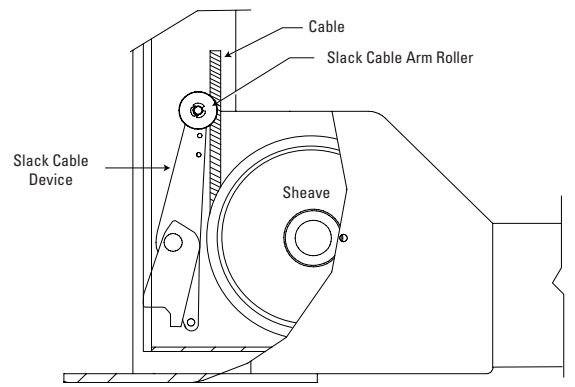

Fig. 19

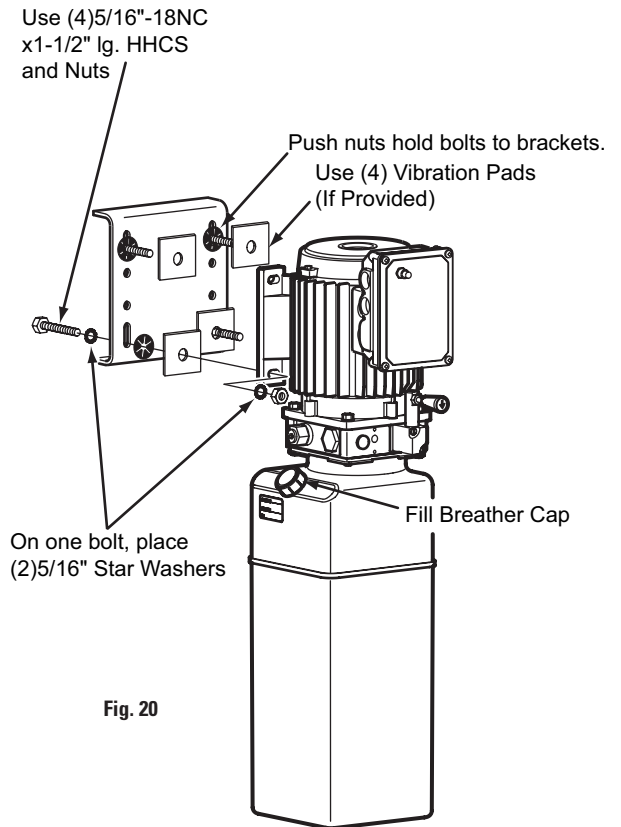

Fig. 20

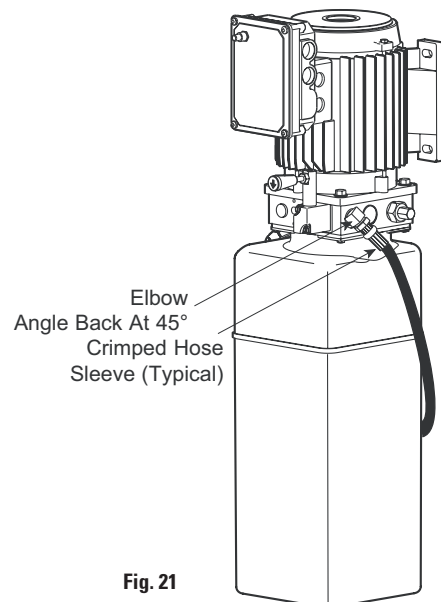

Fig. 21

16. Electrical: Have a certified electrician run appropriate power supply to motor, Fig. 23 and Fig. 24. Size wire for 20 amp circuit. See Motor Operating Data Table.

CAUTION Never operate the motor on line voltage less than 208V. Motor damage may occur.

IMPORTANT Use separate circuit for each power unit. Protect each circuit with time delay fuse or circuit breaker. For single phase 208-230V, use 20 amp fuse. Three phase 208-240V, use 15 amp fuse. For three phase 400V and above, use 10 amp fuse. For wiring see Fig. 23 and Fig. 24. All wiring must comply with NEC and all electrical codes.

Note: 60Hz. single phase motor CAN NOT be run on 50Hz. line without a physical change in the motor.

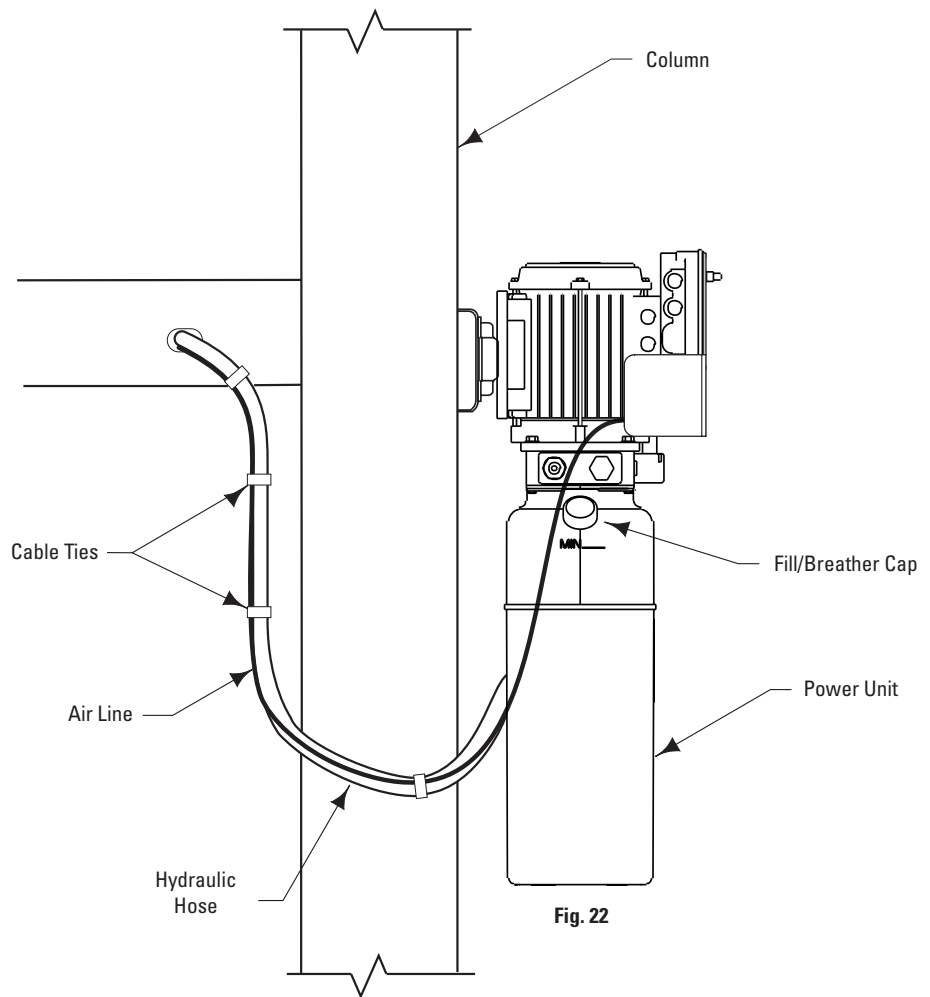

Fig. 22

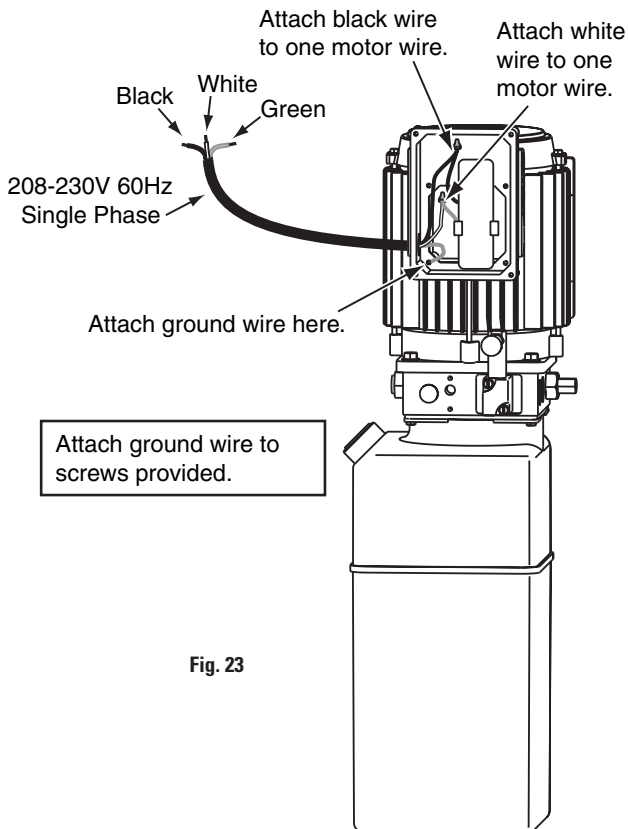
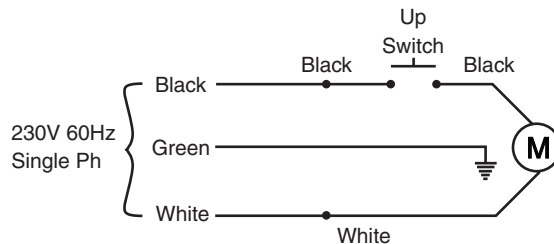

Fig. 23

Single Phase Power Unit

MOTOR OPERATING DATA TABLE - SINGLE PHASE	
LINE VOLTAGE	RUNNING MOTOR VOLTAGE RANGE
208-230V 50Hz.	197-253V
208-230V 60Hz.	197-253V

Note: 60Hz. Single phase motor CAN NOT be run on 50Hz. line without a physical change in the motor.



17. Oil Filling: Use Dexron III ATF, or hydraulic fluid that meets ISO 32 specifications. System capacity is thirteen (13) quarts. Use Dexron III ATF or equal. Fully lower lift. Remove fill/breather cap, Fig. 22. Fill to minimum fill line on tank, replace cap.

Note: If fill/breather cap is lost or broken, order replacement.

NOTE: Two Different Drum Switches were used please select one of the two options below.

NOTES:

1. Unit not suitable for use in unusual conditions. Contact Rotary for moisture and dust environment duty unit.
2. Control Box must be field mounted to power unit.
3. Motor rotation is counter clockwise from top of motor.

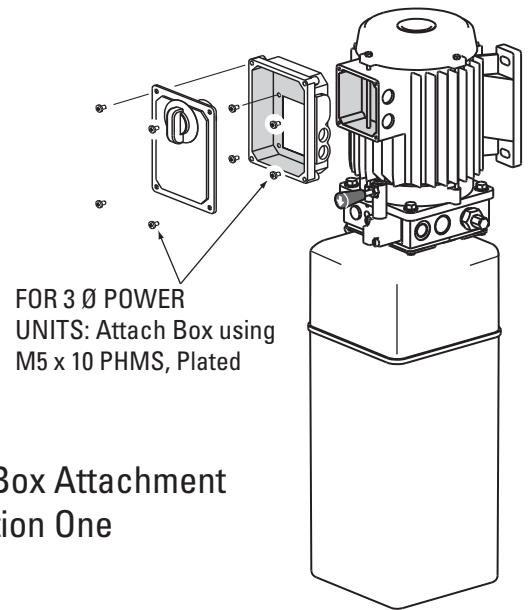
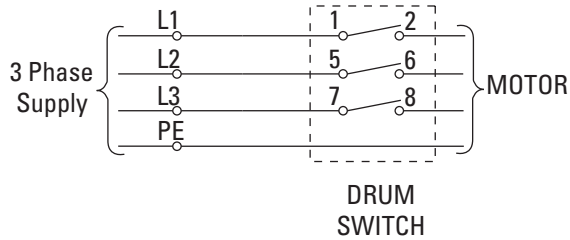

Capacitor Box Attachment Option One

Fig. 24

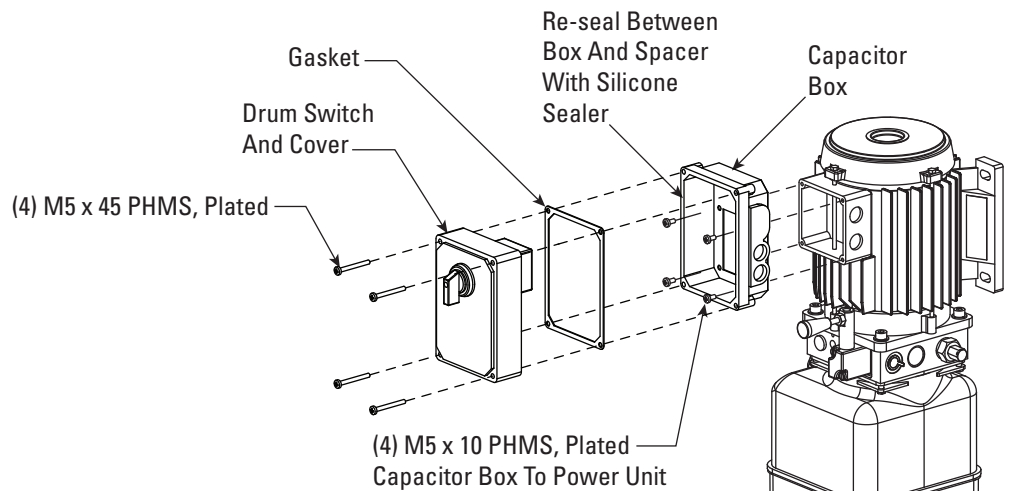

Capacitor Box Attachment Option Two

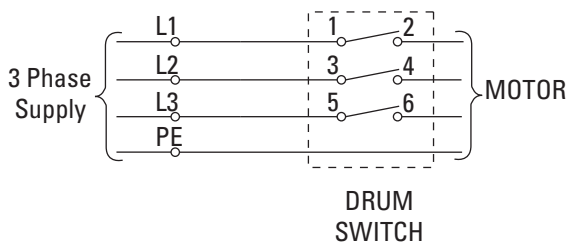

MOTOR OPERATING DATA TABLE - THREE PHASE	
LINE VOLTAGE	RUNNING MOTOR VOLTAGE RANGE
208-240V 50/60Hz.	197-253V
400V 50Hz.	360-440V
440-480V 50/60Hz.	396V-528V
575V 60Hz.	518V-632V

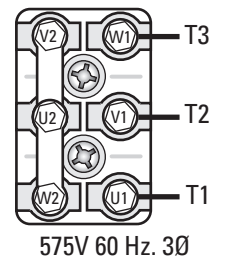
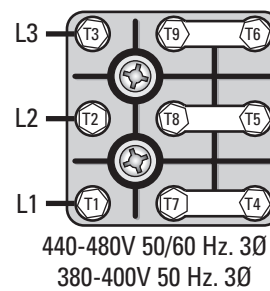
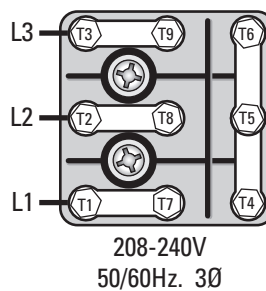

18. Air Line Connections:

Note: Locking latches require 100 psi. min. to 120 psi. max. air pressure.

IMPORTANT A filter/regulator/lubricator must be installed on air supply at lift. Failure to do so will void the warranty.

Note: Cut air line tubing with sharp blade to length as required. Tubing must be cut square with no burrs. To assemble air line tubing into fitting, use firm, manual pressure to push tubing into fitting until it bottoms, Fig. 25. If removal of the air line tubing from the fitting is ever required, hold Push Sleeve in (against fitting) and, at the same time, pull out on tubing.

- A. Lift should be at full height and lowered on latches.
- B. Run 3/8" air line from existing facility main air supply to the FRL. Run 3/8" air line from FLR to reducing tee, Fig. 26.
- C. Connect reducing tee to air valve, Fig. 26.
- D. Attach air valve to air valve bracket, Fig. 26.
- E. **Air Valve Bracket:**
Remove motor warnings decal from motor cover. Remove motor cover screws. Place air valve bracket on top of motor cover so that the raise switch protrudes through the hole in the air valve bracket. Mount air valve bracket and motor cover with the existing single phase (4) M5 x 15 PHMS motor cover screws or supplied (4) M5 x 50 PHMS for three phase, Fig. 26.

- F. Attach enclosed NP280 decal (ACTUATE TO RELEASE LATCHES) on air valve bracket. Run 1/4" air line from air valve to the slot in the fixed runway. Cut air line and attach to Tee in front yoke, Fig. 27. This air line is for locking latches.
- G. Run 1/4" air line from the Tee of the runway slot through the hole in the rear yoke and into the air cylinder, Fig. 27.
- H. If lift has internal air, remove plug in reducing tee and connect the 3/8" line coiled inside of runway, Fig. 26.
- I. Check for air leaks by depressing air valve. Repair as required.
- J. Use provided cable ties to tie air line to hydraulic hose between power unit and lift.
- K. Actuate air valve and check latch operation on all four corners. The locking latches should pull in beyond yoke ends to clear the latch bars located in all four columns, Fig. 28.
- L. Use cable ties provided to tie 3/8" air supply to electrical supply conduit at approximately 2'-0" intervals.

- 19. Bleeding:** Lift must be fully lowered before changing or adding fluid. Raise and lower lift six times. The cylinder is self-bleeding. After bleeding system, fluid level in power unit reservoir may be down. Add more ATF or ISO32 hydraulic oil, if necessary, following instructions in Step 16. To pressure test, run lift to full rise and run motor for approximately 5 seconds. Stop and check all fittings and hose connections. Tighten or reseal if required. Lower lift. If fill/breather cap, Fig. 22, is lost or broken, order replacement.

Note: Some test fluid may be spilled from the cylinder breather vent during bleeding of the system.

- 20. Assemble** ramp/chocks and wheel stops to runways using hinge pins and cotter pins. Ramp chocks go on rear and wheel stops go on front of runway, Fig. 29.

Note: For drive-thru applications, ramp chocks will go on both ends of runways.

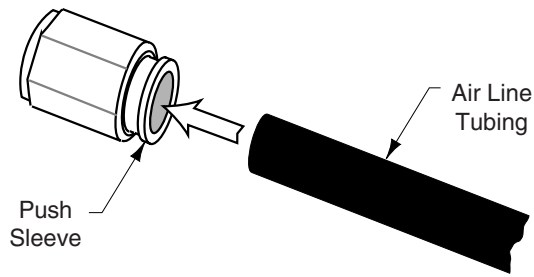

Fig. 26

Air Valve Assembly For Motor Brackets

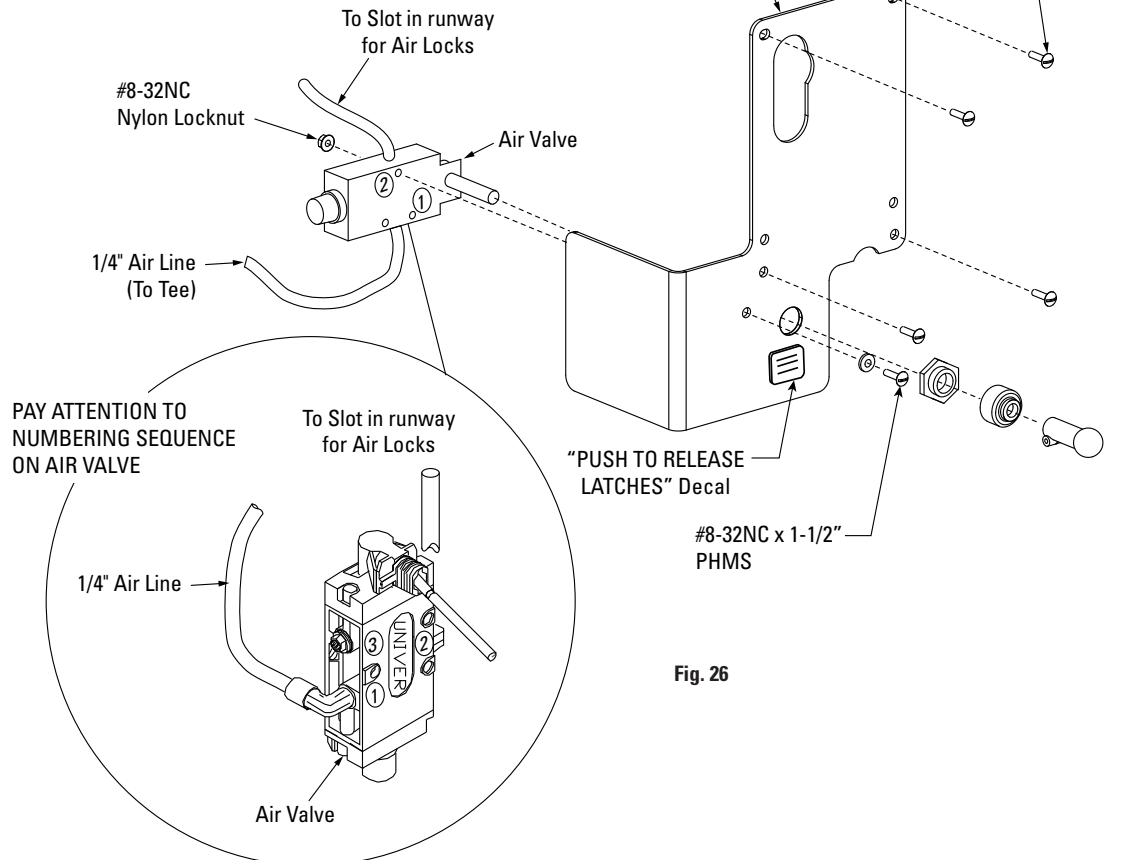
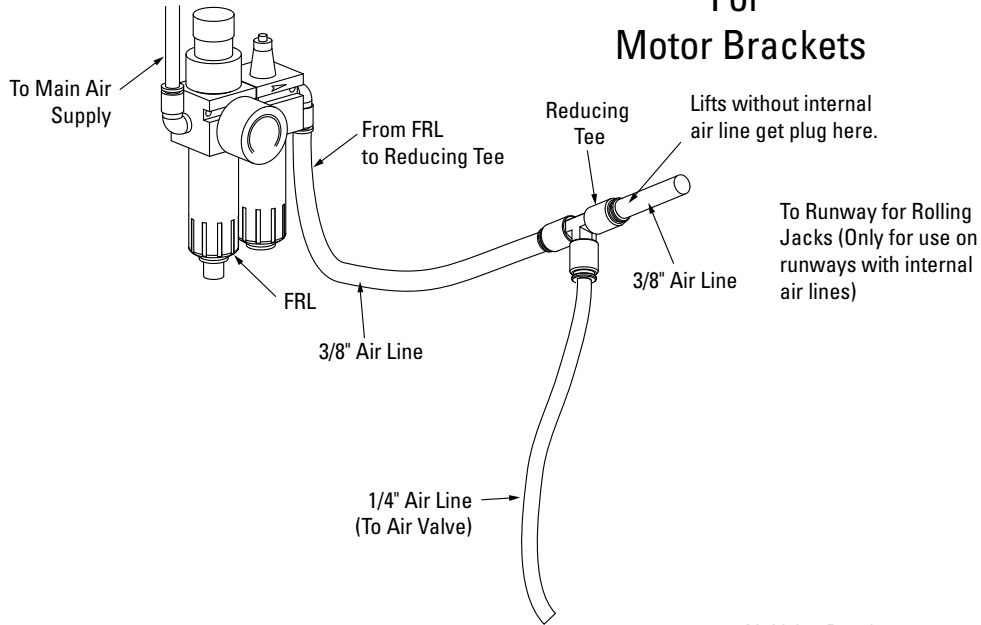

Fig. 26

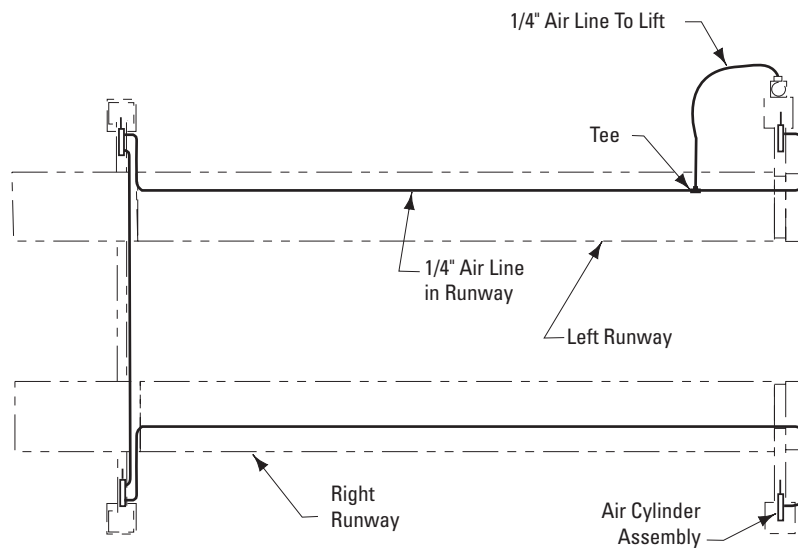

Fig. 27

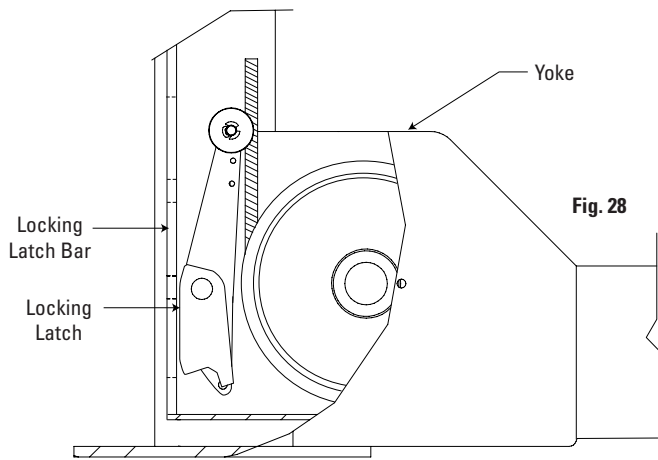

Fig. 28

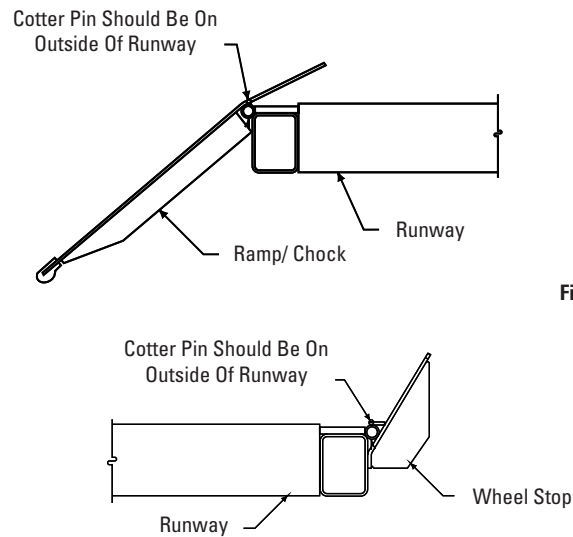

Fig. 29

21. Final Adjustments:

- A. Load vehicle such as 3/4 ton truck or van onto lift.
- B. Cable Adjustment:
 1. Slowly jog the power unit, allowing two seconds between jogs, until a latch or latches are heard engaging. Check all corners to see which latch(es) have engaged. The corner(s) that are engaged will not be adjusted. Proceed to one of the corners that has not engaged and loosen the cable jam nut. Turn the cable adjustment nut clockwise, holding the cable with the square end of the threaded portion under the top plate, Fig. 30, until you hear the latch engage, then stop. Lock down the adjustment nut with the jam nut.
 2. Proceed to the other corners until all latches have clicked into locking position.
 3. Raise and lower lift to check for lock engaging sequence. The sound of lock engagement should sound simultaneously, the front cables may click slightly before the rear to compensate for the loaded condition.

CAUTION If you run out of the square holding area on the cable under the top plate, grip the top threaded portion with Locking Pliers to tighten. If the nut bottoms out or is close to bottoming out on the cable adjustment thread, then all the cables, sheaves and pins should be replaced. See 4-Post Inspection and Maintenance Guide and check for broken cable strands if you must grip the top threaded portion with Locking Pliers. If a broken cable is detected, ALL the cables, sheaves, and pins should be replaced before lift is put into operation.

CAUTION When making changes to adjustment nuts on cable end always leave at least two threads showing between nut and end.

Note: Latches may not click in at the same time when vehicle is being raised. They should be close. Be sure all four corners have passed the locking latch bar slot before lowering lift on locking latches.

Note: All bolts and nuts mentioned in this booklet are grade 5 unless otherwise stated.

Note: Cotter pins are usually good for one time use only. Replace any cotter pin, if removed, with a new cotter pin.

22. Rolling Jack:

A. Adjust rolling jack telescoping ends until roller rests on runway track, Fig. 31. Make sure wheels are on tracks and center rolling jack between runway on end sections.

B. Place jack on runway track at front and rear with air pump facing ends of runways.

C. Recommended operating pressure is 100-120 PSI.

D. Attach rubber stops see Fig. 31.

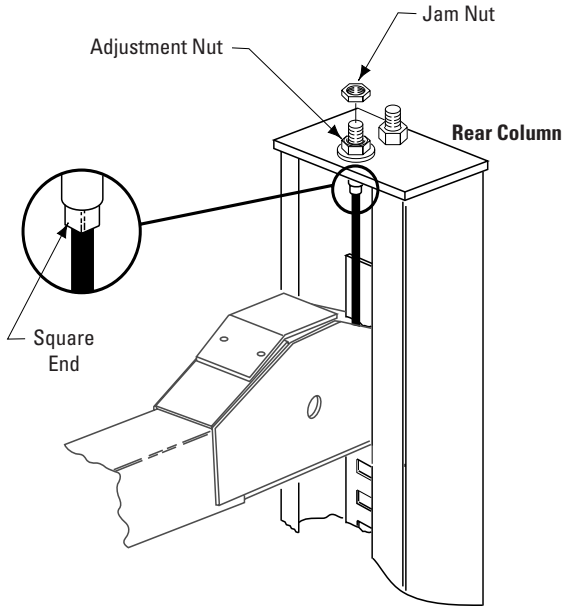
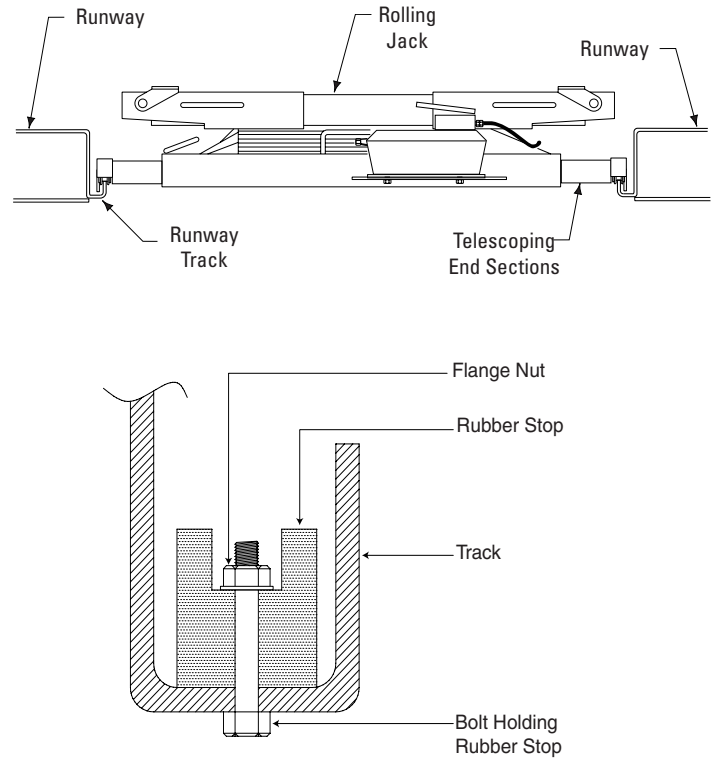

Fig. 30



Attach rubber bridge stops to 5/16" holes 14" off center of runways. Insert 1/4" bolt up through runway and stop. Attach 1/4" flange nut to top of stop.

Fig. 31

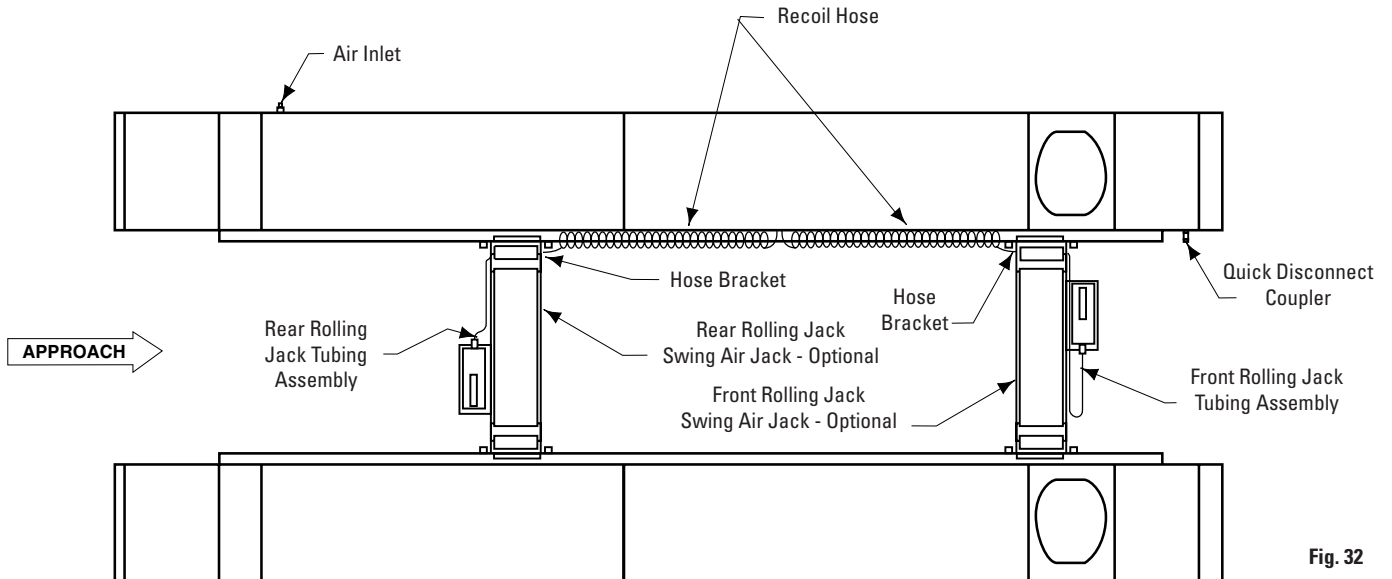

Fig. 32

23. Internal Air Line: (If Installed) This lift is equipped with an internal airline that provides air to both rolling jacks and extra access point for air driven tools (Quick Disconnect Coupler), Fig. 32. All internal air lines are factory assembled.

24. Rear Recoil Hose Installation:

- A. Attach retainer brackets for the rear recoil hose with 3/8"-16NC x 3/4" Lg. hex cap screw, flat washer, lock washer and nut, Fig. 36.
- B. Insert retainer cable through coils of recoil hose, Fig. 37. Run a 1/4"-20NC hex nut down onto each end of retainer cable. Insert each end of cable into retainer brackets. Secure each cable end with another 1/4"-20NC hex nut. Tighten jam nuts, Fig. 36.
- C. Connect one end of provided rear recoil hose to bulkhead T-fitting at midpoint of runway. Connect other end of recoil hose to coupling welded on rolling jack, Fig. 33 and 34.
- D. Connect elbow end of rolling jack tubing assembly to air pump and male end to the coupling, Fig. 33 and 34.

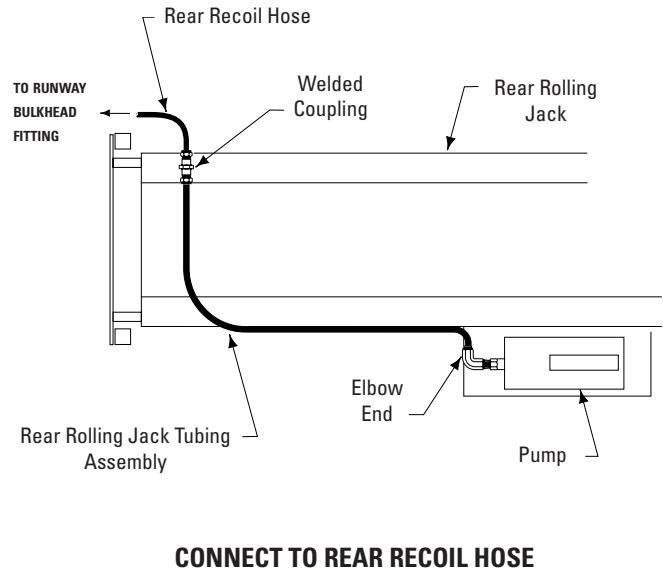

Fig. 33

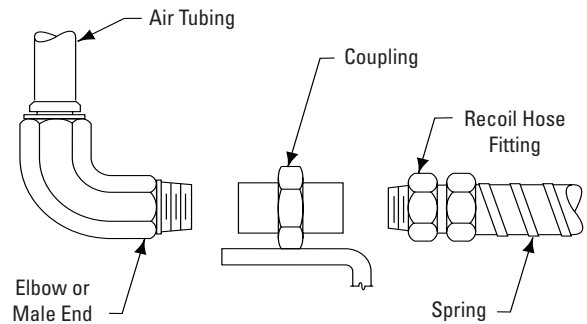

Fig. 34

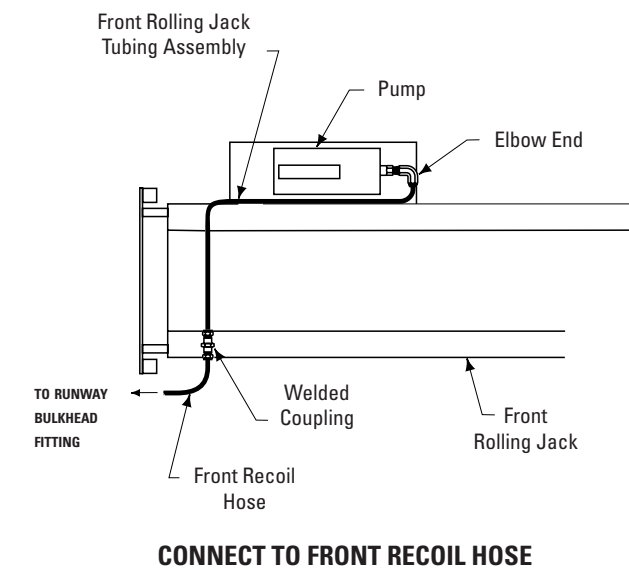
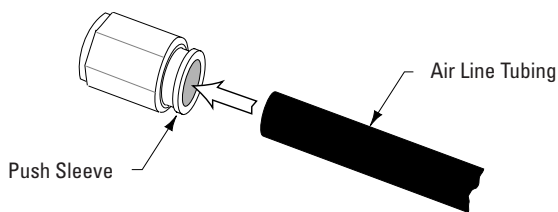

Fig. 35

25. Front Recoil Hose Installation:

- A. Insert retainer cable through coils of recoil hose, Fig. 36. Connect one end of recoil hose to coupling welded on rolling jack, Fig. 34 and 35.
- B. Connect other end of front recoil hose to bulkhead T-fitting in center of runway.
- C. Connect elbow end of rolling jack tubing assembly to air pump, and male end to the coupling, Fig. 34 and 35.

Note: Cut air line tubing with sharp blade to length as required. Tubing must be cut square with no burrs. To assemble air line tubing into fitting, use firm, manual pressure to push tubing into fitting until it bottoms, (see below). If removal of the air line tubing from the fitting is ever required, hold Push Sleeve in (against fitting) and, at the same time, pull out on tubing.

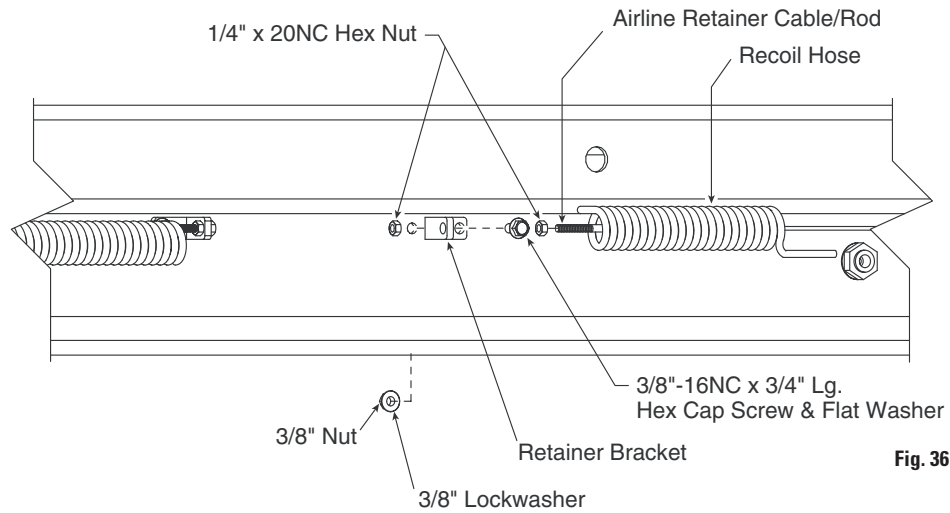

Fig. 36

26. Aligning Turning Radius Guide Bars:

- A. Slightly loosen the turning radius gauge guide bar mounting bolts.
- B. Place a weighted string, Fig. 37, across the runways so that the string is touching along the full length of both rear guide bars. If the string is not touching, tap the ends of the guide bars lightly until the guide bars make full contact against the string. Tighten the rear guide bar mounting bolts securely and remove the string.

- C. Place the turning radius gauges in the recesses of both runways with the pointer and lock pin to the outside of lift, Fig. 38. Position each gauge against the rear guide bars. Then position the front guide bar just against the front edge of the turning radius gauge. Repeat on other runway. (A tolerance of 1/16", end-to-end, is acceptable). Tighten the mounting bolts securely. The turning radius gauges are now square and in proper alignment with each other.

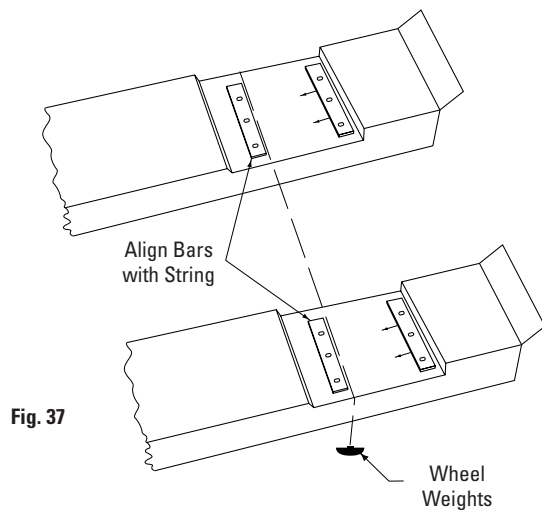

Fig. 37

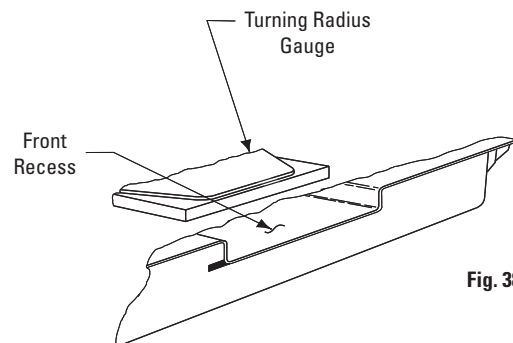

Fig. 38

WHEEL SERVICE

(AR014 ONLY)

27. Runway Leveling Adjustments:

- A. Engineer's automatic level (transit):
 1. Locate the Level, at a convenient location in the shop that allows an unobstructed view of all four corners of the Lift's runways.
 2. Follow the Level manufacturer's instructions for proper setup of the Level. Be sure it is adjusted level in all directions.
 3. Readjust Level if tripod or Level is bumped or disturbed.
 - B. Raise lift approximately 28"- 32", then lower lift until all locking latches are engaged in each column and the runways are in full down position on locks.
 - C. Place the Level target on the right/front wheel turning radius gauge.
 - D. Beginning with "A" position, Fig. 39, sight the Level to the target and mark the number or the graduation on the inch scale of the target that aligns to the crosshairs of the Level, Fig. 40.
 - E. Next, move the target and place it on the turning radius gauge at point "B", Fig. 39.
 - F. Rotate the Level and focus on the target scale.
 - G. Adjust the adjustment nut on the locking latch plate adjustment stud at the top of the column at "B", Fig. 39, by loosening the jam nut and turning adjustment nut until the crosshairs of Level align to reference mark on the target scale.
 - H. Repeat steps E., F. and G., locating the target assembly at points "C" and "D" and adjusting locking latch plate adjustment stud at each corresponding column until the reference mark on the target scale is on the crosshairs of the Level.
- Rack Runways Must Be Level Side To Side, Maximum Tolerance Front To Rear 1/16".
- I. Always recheck the level of the runways to be sure all four locking latch plates are adjusted correctly. Start at point "A" and recheck level at points "B", "C", and "D", Fig. 39. Readjust, if needed. The runways are now level at all four points.
 - J. To complete the leveling procedures, lock each locking latch plate jam nut tightly against bottom of column top plate, Fig. 41. Also tighten down 1/4" bolt on front latch bar bases.

Note: Use a pencil, marking pen or attach a paper clip onto the target scale at the crosshair reference.

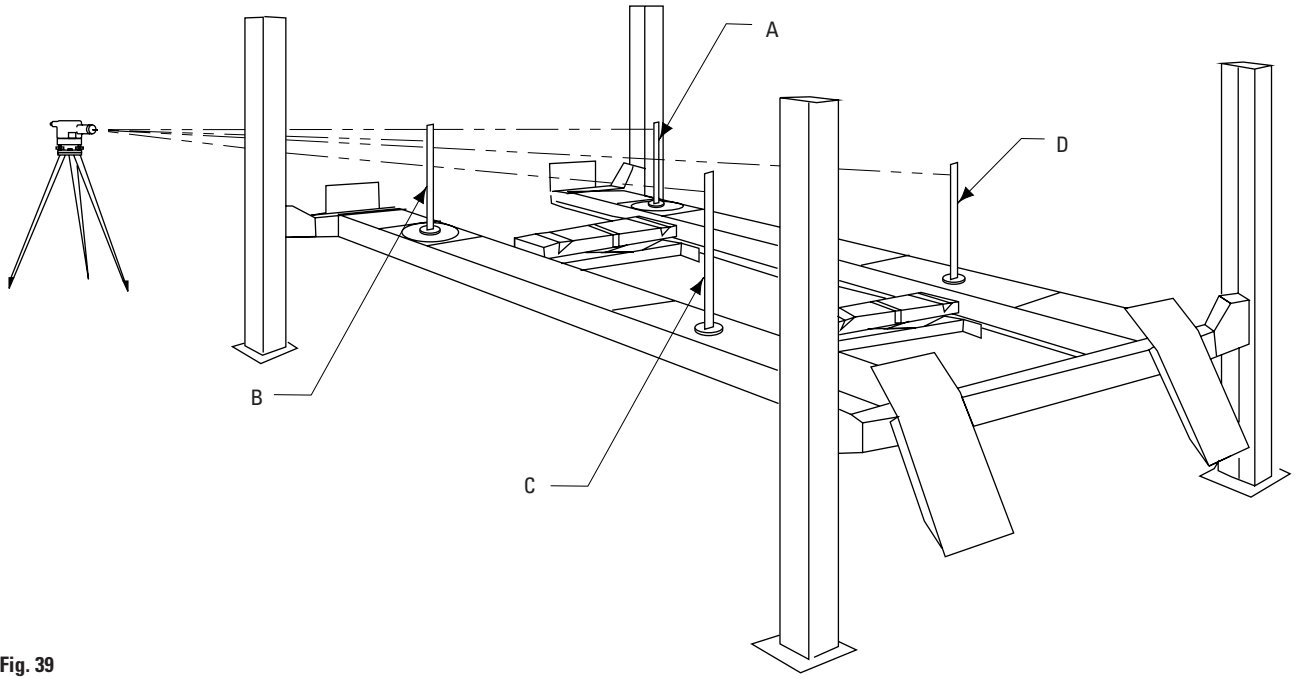

Fig. 39

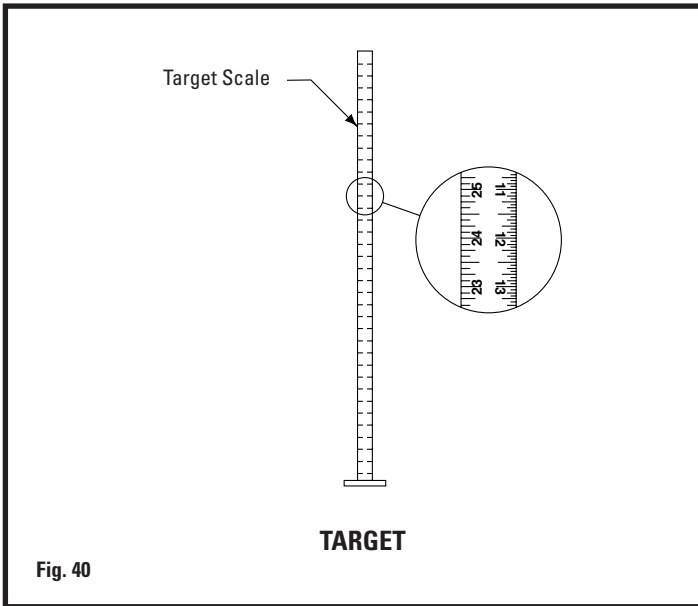

Fig. 40

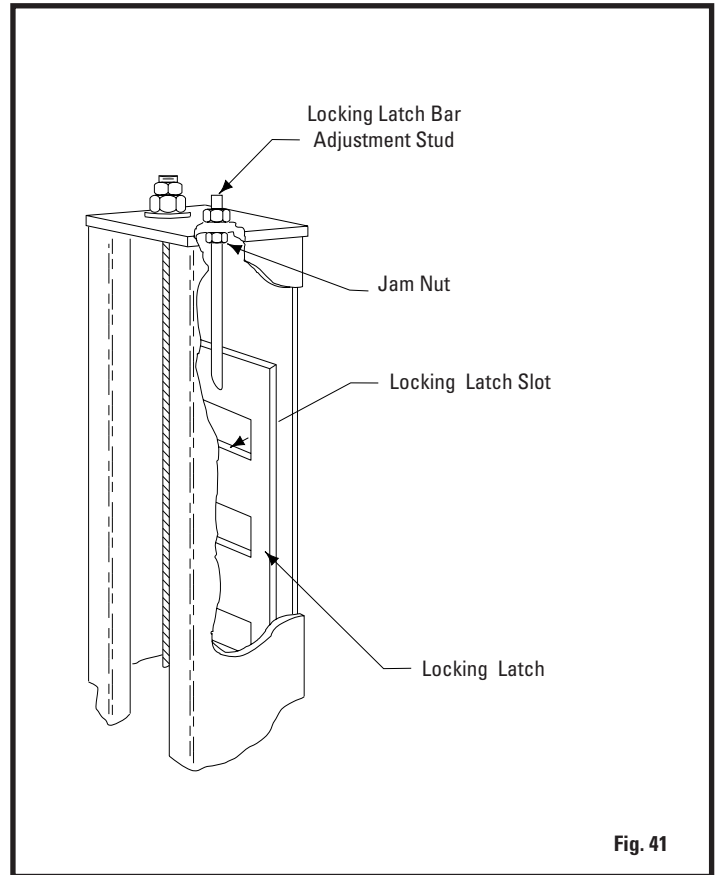

Fig. 41

NOTES

NOTES

ATTENTION INSTALLER:

Please return this booklet to literature package and give to lift owner/operator.

Trained Operators and Regular Maintenance Ensures
Satisfactory Performance of Your Rotary Lift.

Contact Your Nearest Authorized Rotary Parts Distributor for Genuine Rotary Replacement Parts. See
Literature Package for Parts Breakdown.

DATE	REV.	DESCRIPTION
3/20/2007	-	New 4-Post Issue.
5/10/2007	A	Added column tie bar.
6/6/2007	B	Added vibration pads to power unit.
9/21/2007	C	Updated drum switch wiring.
11/5/2008	D	Updated anchor bolt torque values.
10/18/2010	E	Updated drum switch and air valve bracket graphics.
2/17/2011	F	Updated concrete requirements.
11/08/2012	G	Added greasing information

Rotary World Headquarters

2700 Lanier Drive
Madison, IN 47250, USA
www.rotarylif.com

North America Contact Information

Tech. Support:
p 800.445.5438
f 800.578.5438
e userlink@rotarylif.com
Sales:
p 800.640.5438
f 800.578.5438
e userlink@rotarylif.com

World Wide Contact Information

World Headquarters/USA: 1.812.273.1622
Canada: 1.905.812.9920
European Headquarters/Germany: +49.771.9233.0
United Kingdom: +44.178.747.7711
Australasia: +60.3.7660.0285
Latin America / Caribbean: +54.3488.431.608
Middle East / Northern Africa: +49.771.9233.0

© Vehicle Service GroupSM

Printed in U.S.A., All Rights Reserved. Unless otherwise indicated, ROTARY, and all other trademarks are property of Dover Corporation and its affiliates.

