



World Leader in Lift Productivity

SPO12

(410 Series)

Two Post Surface Mounted Frame Engaging Lift

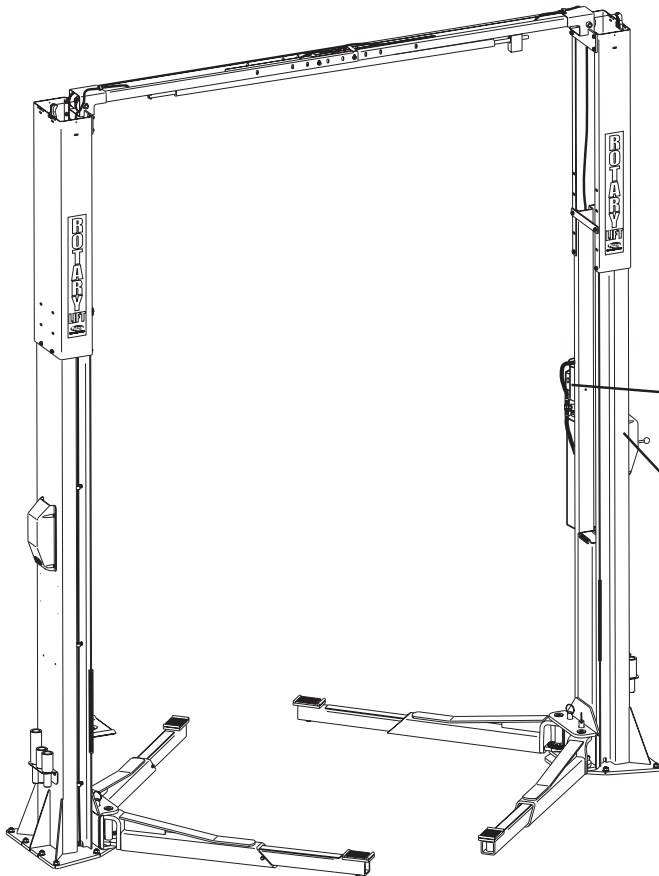

Rotary	PT#	_____	N°	_____
	PH	_____	MAX AMB	_____
	DUTY	_____	INS	_____
	THERMAL PROTECTION			
	VOLTS	_____	HP	_____
	AMPS	_____	Kw	_____
	HZ	_____	RPM	_____
			IP	_____

WARNING: MOTOR MUST BE GROUNDED IN ACCORDANCE WITH LOCAL AND NATIONAL ELECTRICAL CODES TO PREVENT SERIOUS ELECTRICAL SHOCKS

CE IEC 34-1 ETL ETL NF933 -Rev

Rotary
800-445-5438

IMPORTANT
DO NOT REMOVE THIS TAG
WARRANTY IDENTIFICATION

MODEL:
CAP. LBS:
SERIAL NUMBER

MADE IN THE USA

Rotary Lift A **DOVER** INDUSTRIES COMPANY Madison, IN

MANUFACTURED UNDER ONE OF THESE PATENTS 5009287

PARTS BREAKDOWN

IMPORTANT: When ordering parts or requesting service always give exact model and power unit serial number. Model number is shown on nameplate attached to air lock release valve. Power unit serial number is located on side of power unit.

OWNERS RECORD
Complete information at right and keep in a safe place.

Date Installed _____

Installed in Bay # _____

Power Unit Serial # _____

Power Unit Model # _____

Lift Serial # _____

Lift Model # _____

NOTE: For replacement parts -See your nearest Rotary Parts Distributor.

PB 2-2-30-2
Rev. B 06/05/2003

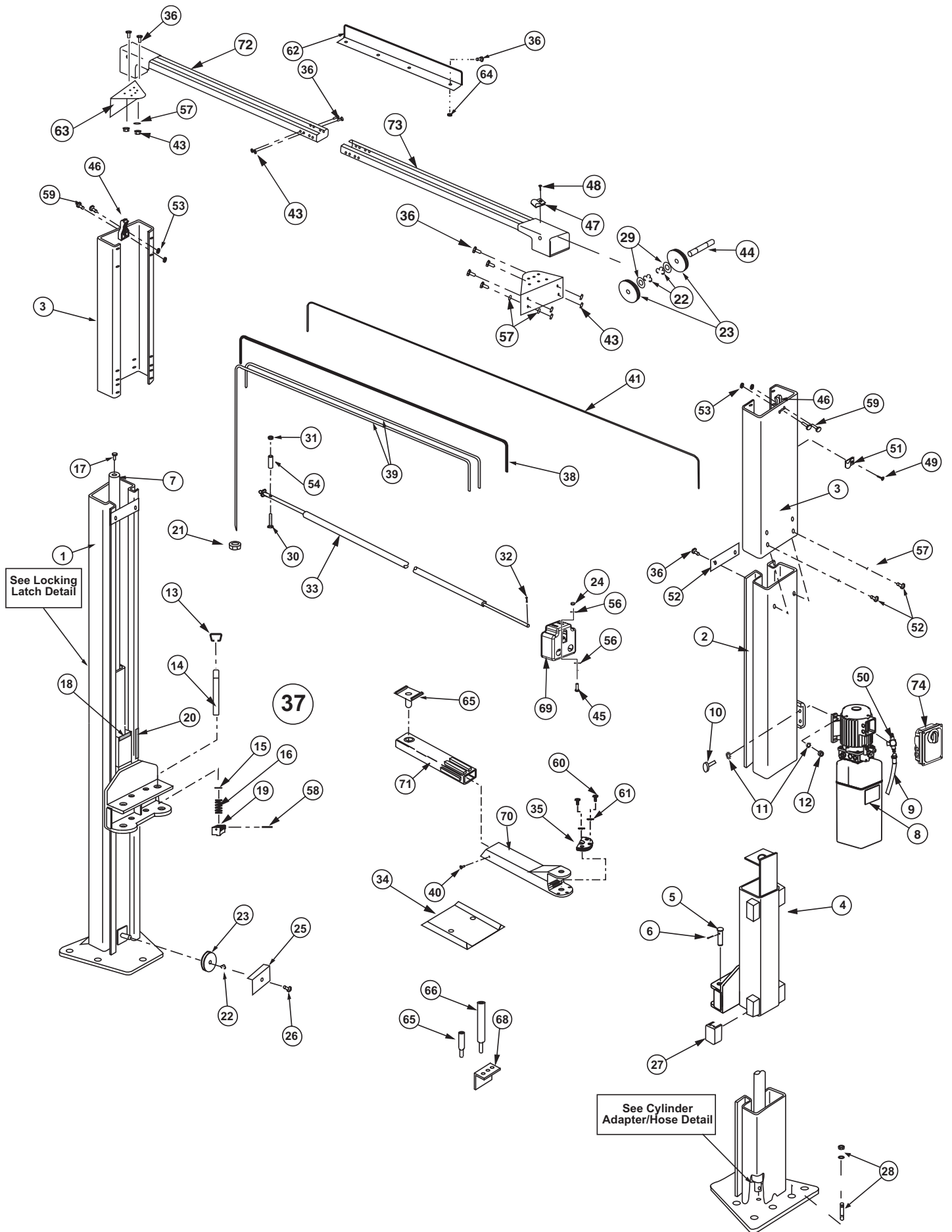

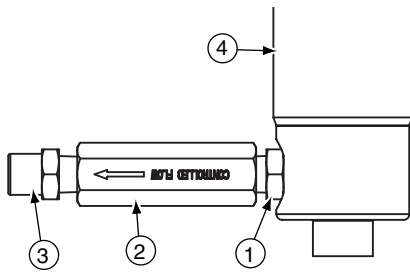

CYLINDER ADAPTER/HOSE DETAIL PARTS LIST		
ITEM NO.	DESCRIPTION	PART NO.
1	Lenz 6-4APN Adapter	16095
2	Flow Control	N344-1
3	Lenz 3105-6-4 Adapter	16094
4	Hydraulic Cylinder	N342

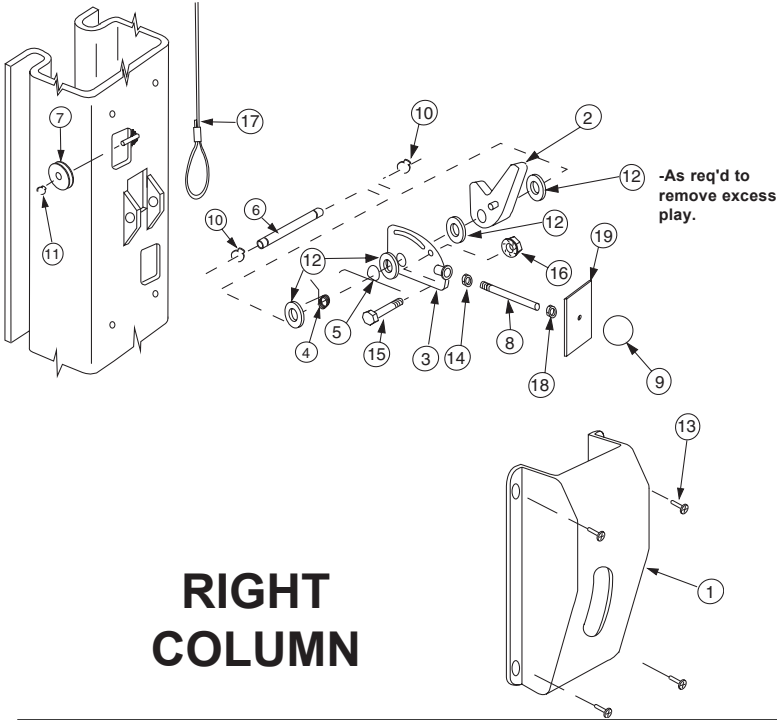

LOCKING LATCH DETAIL PARTS LIST		
ITEM NO.	DESCRIPTION	PART NO.
1	Control Side Cover	FJ7452
2	Locking Latch Dog	N165-1
3	Control Plate	FJ7382-5
4	Spring	FJ7566-10
5	Spring	FJ7382-9
6	Latch Shaft	FJ7382-34
7	Locking Latch Sheave	FJ7322
8	Handle	FJ7382-18
9	Ball Handle	FC134-91
10	Truarc Klipring #5304-75 for 3/4" Shaft	41411
11	Truarc Klipring #5304-37 for 3/8" Shaft	41410
12	1 1/2" O.D. x 3/4" I.D. x .045" Mach. Bush.	41388
13	5/16"-18NC x 3/8" Lg. PHMS	40227
14	3/8" - 16NC Hex Jam Nut	40658
15	Shoulder Bolt, 5/16"-20 NC x 1- 1/4"	40220
16	Flanged Locknut, 1/4" - 20NC	41423
17	Latch Cable	FJ7595-1
	EH-1 and EH-2	FJ7600
18	1/2"-13NC Jam Nut	40700
19	Slot Cover	N617

RIGHT COLUMN

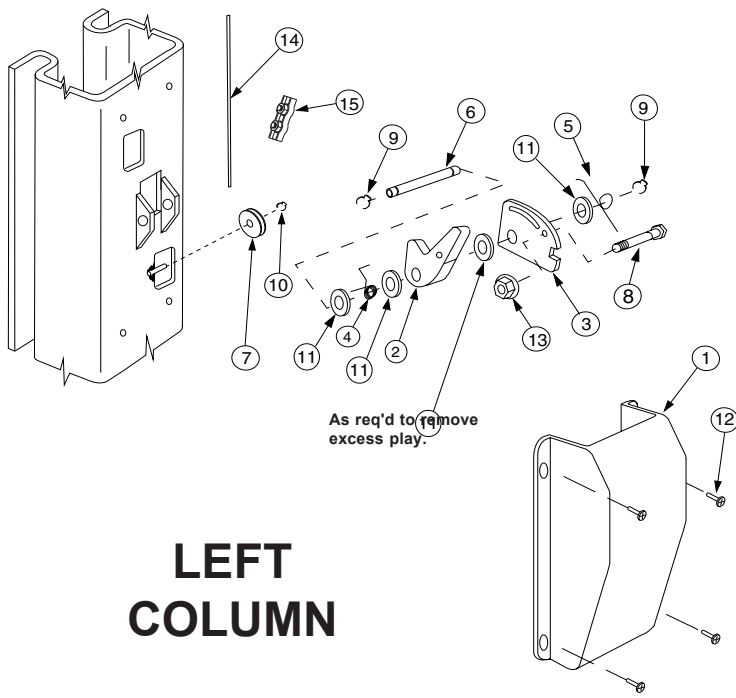

LOCKING LATCH DETAIL PARTS LIST		
ITEM NO.	DESCRIPTION	PART NO.
1	Latch Cover	FJ7451
2	Locking Latch Dog	N165-1
3	Control Plate	FJ7382-5
4	Spring	FJ7566-10
5	Spring	FJ7382-9
6	Latch Shaft	FJ7382-34
7	Locking Latch Sheave	FJ7322
8	Shoulder Bolt 5/16"-20NC x 1-1/4"	40220
9	Truarc Klipring #5304-75 for 3/4" Shaft	41411
10	Truarc Klipring #5304-37 for 3/8" Shaft	41410
11	1 1/2" O.D. x 3/4" I.D. x .045" Mach. Bush.	41388
12	5/16"-18NC x 3/8" Lg. PHMS	40227
13	Flanged Locknut, 1/4" - 20NC	41423
14	Latch Cable	FJ7595-1
	EH-1 and EH-2	FJ7600
15	Latch Cable Clamp	N63-1

LEFT COLUMN

World Headquarters:
Rotary Lift
 A **DOVER** COMPANY
 2700 Lanier Drive
 Madison, Indiana USA
 Phone: 1.800.445.5438
 Phone: 1.812.273.1622
 Fax: 1.800.578.5438
 Fax: 1.812.273.6502
 userlink@rotarylif.com
 www.rotarylif.com

Italy:
 (Regional Sales Office)
Rotary Lift Europe S.r.l.
 Cadriano (BO)
 Phone: +39.051.763384
 Fax: +39.051.763395
 info@rotaryeurope.com

Germany:
 (European Sales Headquarters)
Rotary Lift Germany GmbH
 Bensheim
 Phone: +49.6251.582.6420
 Fax: +49.6251.582.6422
 sales@rotarylif.de

United Kingdom:
 (Regional Sales Office)
Rotary Lift (UK) LTD.
 Halstead, Essex
 Phone: +44.178.747.7711
 Fax: +44.178.747.7720
 sales@rotarylif.idps.co.uk

Canada:
 (Regional Sales Office)
Rotary Lift Canada
 Mississauga, Ontario
 Phone: 905.812.9920
 Fax: 905.812.9719
 canada@rotarylif.com

Austral-Asia:
 (Regional Sales Office)
Rotary Lift Austral/Asia
 Petaling Jaya, Malaysia
 Phone: +60.3.7660.0285
 Fax: +60.3.7660.0289
 rlim@rotarylif.com

